

Date: 7/21/2023

Username: twolfel

Division: HIGHWAY

Filename: ... \00\HIGHWAY\MSTA\sect.dgn

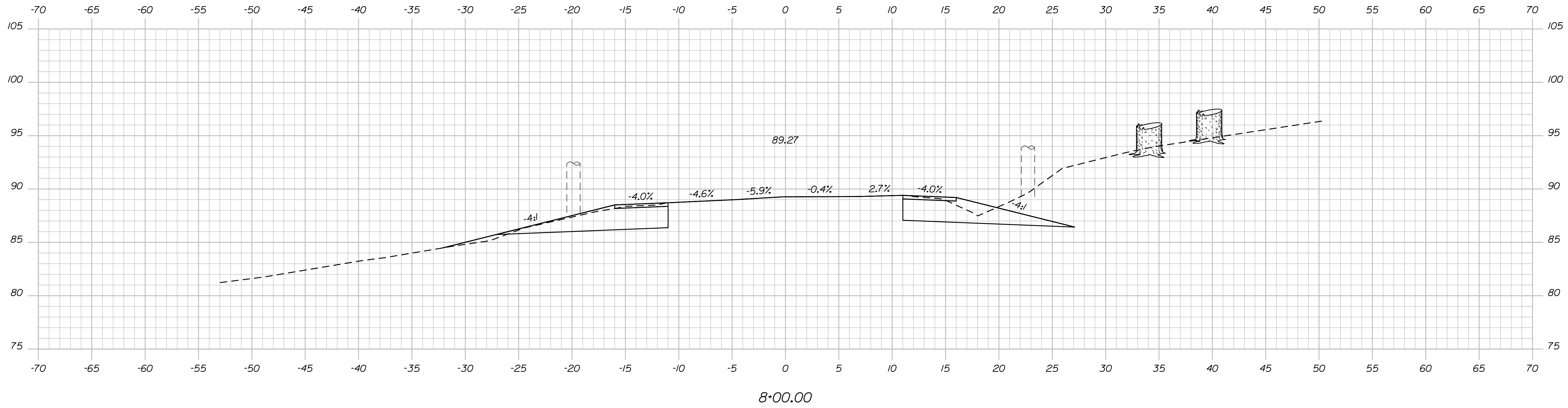

WORKING CROSS SECTIONS -
 MODEL HAS NOT BEEN FULLY
 DEVELOPED

STATE OF MAINE
 DEPARTMENT OF TRANSPORTATION

ELIOT
 ROUTE 103 YORK COUNTY
 CROSS SECTIONS

SHEET NUMBER

©SHEET

OF 22

| | | | | | |
|-----------------|-------------|-----|-------------|---------|-------------|
| PROJ. MANAGER | J. BRUBAKER | BY | J. BRUBAKER | DATE | |
| CHECKED | T. WOLFEL | CHL | LEM | 06/2023 | SIGNATURE |
| DESIGN DETAILED | L. WEEK | LEM | | | P.E. NUMBER |
| DESIGN DETAILED | | | | | DATE |
| REVISIONS 1 | | | | | |
| REVISIONS 2 | | | | | |
| REVISIONS 3 | | | | | |
| REVISIONS 4 | | | | | |
| FIELD CHANGES | | | | | |

HIGHWAY PLANS

Date: 7/21/2023

Username: twolfel

Division: HIGHWAY

Filename: ... \00\HIGHWAY\MSTA\wsect.dgn

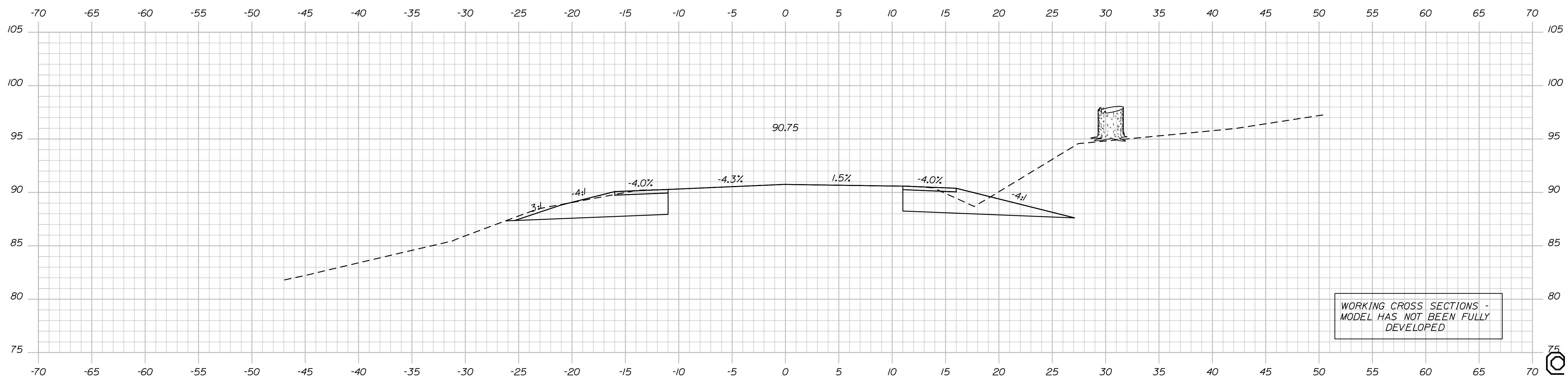
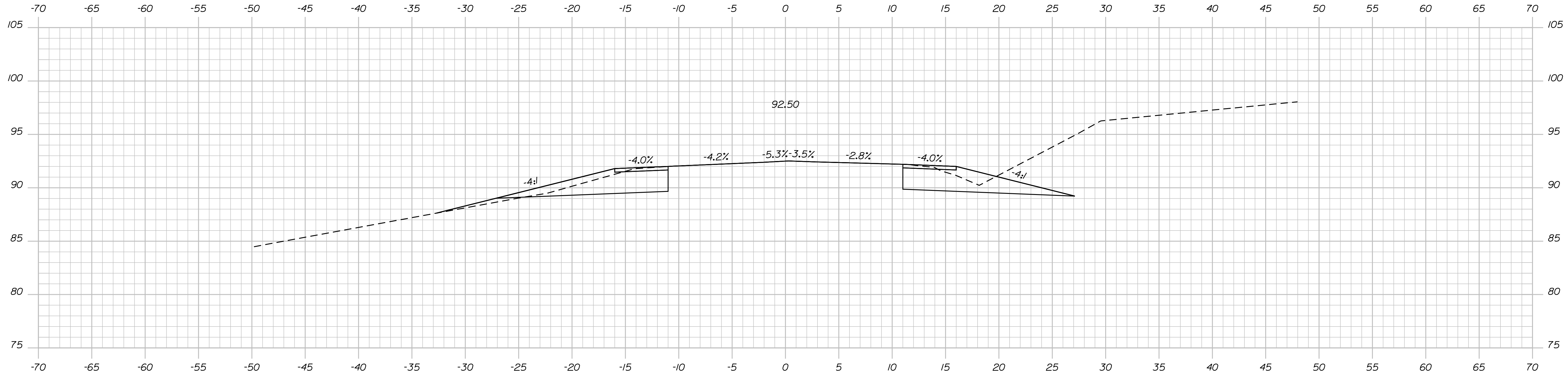

WORKING CROSS SECTIONS -
MODEL HAS NOT BEEN FULLY
DEVELOPED

STATE OF MAINE
DEPARTMENT OF TRANSPORTATION

HIGHWAY PLANS

DATE
06/20/23

BY
CHL
LEM

PROJ. MANAGER
J. BRUBAKER

DESIGN DETAILED
T. WOLFEL

CHECKED-REVIEWED
L. MEEK

DESIGN DETAILED

REVISIONS 1

REVISIONS 2

REVISIONS 3

REVISIONS 4

FIELD CHANGES

SIGNATURE

P.E. NUMBER

DATE

ELIOT ROUTE 10 YORK COUNTY

CROSS SECTIONS

SHEET NUMBER

OF SHEET

OF 22

Sta. 8+50.00 to Sta. 9+00.00

Date: 7/21/2023

Username: twolfel

Division: HIGHWAY

Filename: ... \00\HIGHWAY\MSTA\sect.dgn

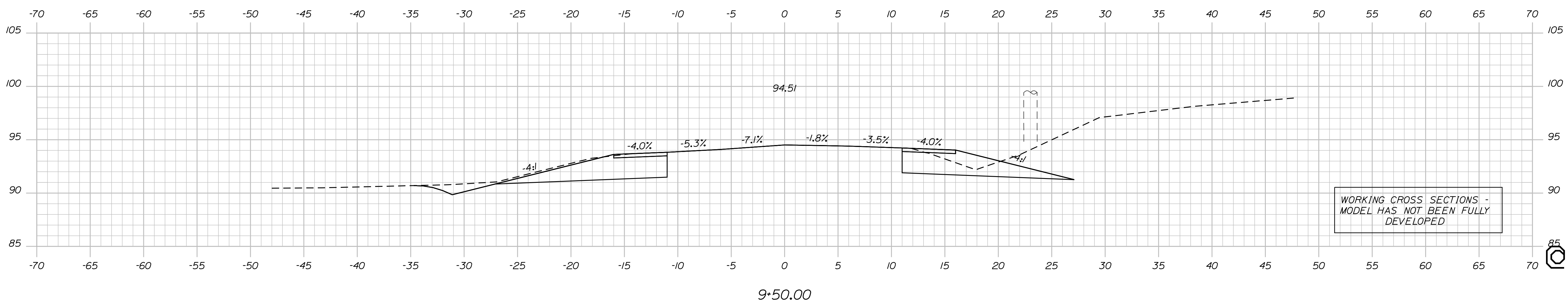
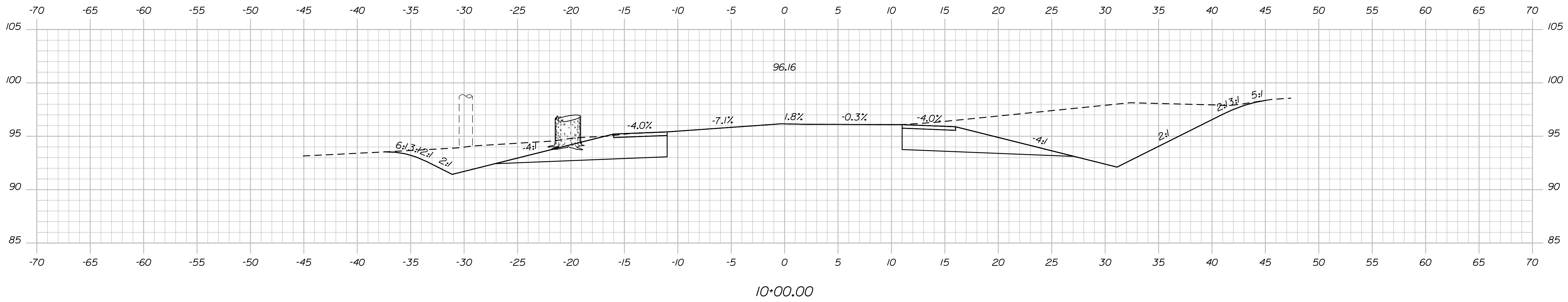
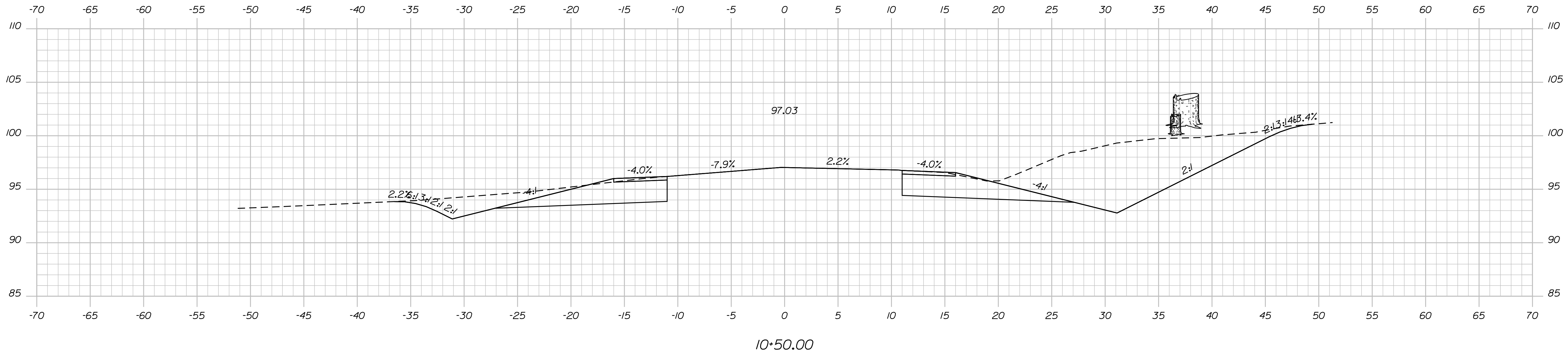

WORKING CROSS SECTIONS -
MODEL HAS NOT BEEN FULLY
DEVELOPED

STATE OF MAINE
DEPARTMENT OF TRANSPORTATION

ELIOT
ROUTE 103 YORK COUNTY

| PROJ. MANAGER | BY | DATE |
|------------------|-----------|-------------|
| J. BRUBAKER | T. WOLFEL | 06/2023 |
| CHECKED-REVIEWED | CHL | SIGNATURE |
| DESIGN-REVIEWED | LEM | P.E. NUMBER |
| DESIGN-REVIEWED | | DATE |
| REVISIONS 1 | | |
| REVISIONS 2 | | |
| REVISIONS 3 | | |
| REVISIONS 4 | | |
| FIELD CHANGES | | |

CROSS SECTIONS

SHEET NUMBER

OF SHEET

OF 22

Date: 7/21/2023

Username: twolfel

Division: HIGHWAY

Filename: ... \00\HIGHWAY\MSTA\sect.dgn

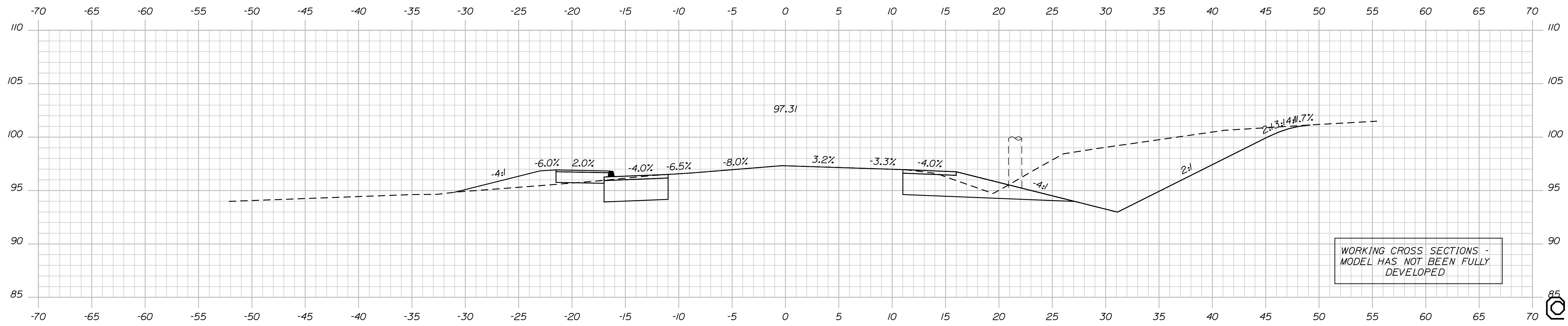
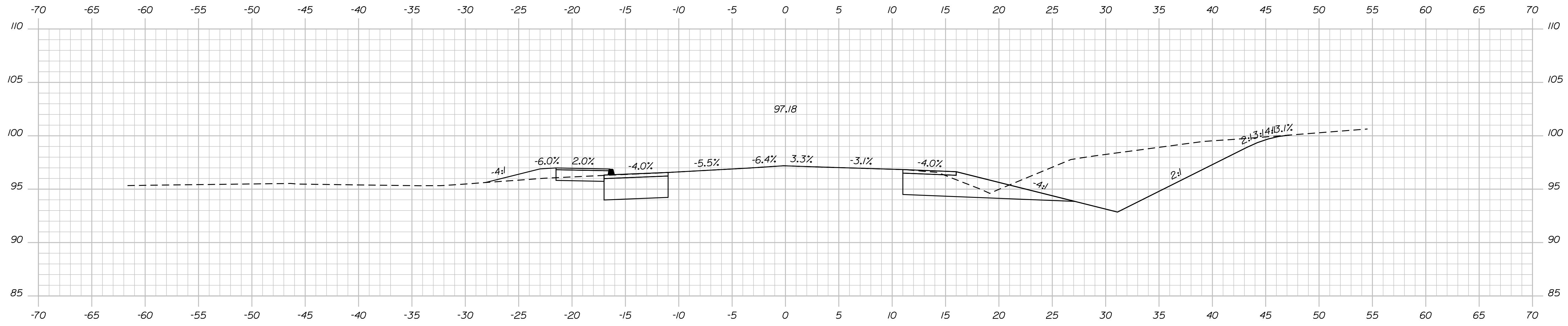
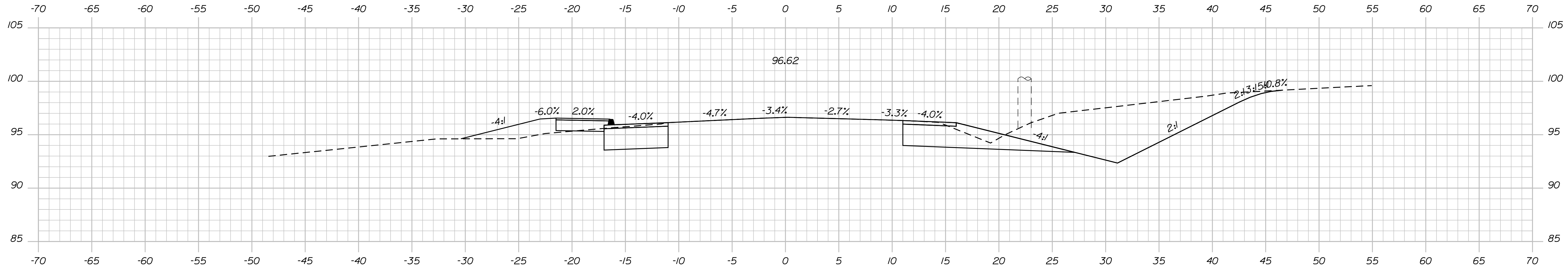

WORKING CROSS SECTIONS -
MODEL HAS NOT BEEN FULLY
DEVELOPED

STATE OF MAINE
DEPARTMENT OF TRANSPORTATION

ELIOT ROUTE 103 YORK COUNTY

CROSS SECTIONS

SHEET NUMBER

OS SHEET

OF 22

| DESIGN/DETAILED | CHECKED/REVIEWED | DATE | BY |
|-----------------|------------------|---------|-----|
| DESIGN/DETAILED | T. WOLFEL | 06/2023 | CHL |
| DESIGN/DETAILED | L. MEEK | | LEM |
| REVISIONS 1 | | | |
| REVISIONS 2 | | | |
| REVISIONS 3 | | | |
| REVISIONS 4 | | | |
| FIELD CHANGES | | | |

SIGNATURE
P.E. NUMBER
DATE

HIGHWAY PLANS

Date: 7/21/2023

Username: twolfel

Division: HIGHWAY

Filename: ... \00\HIGHWAY\MSTA\sect.dgn

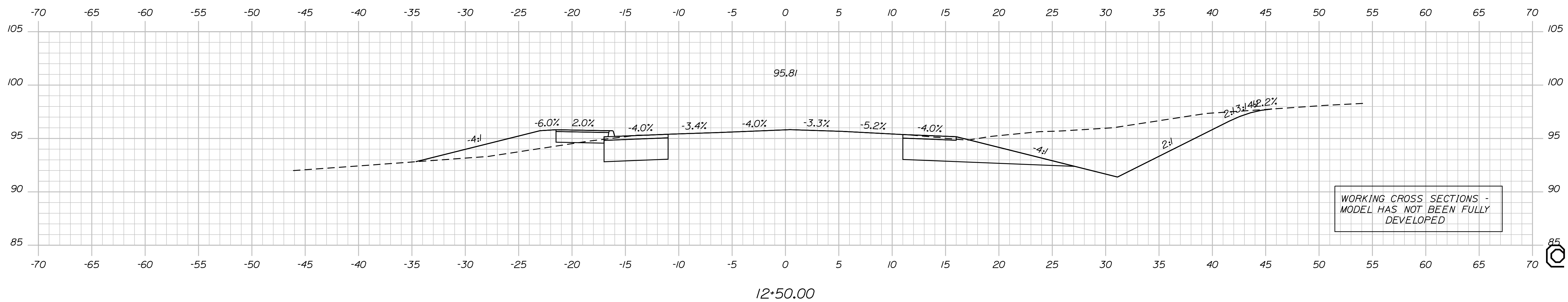
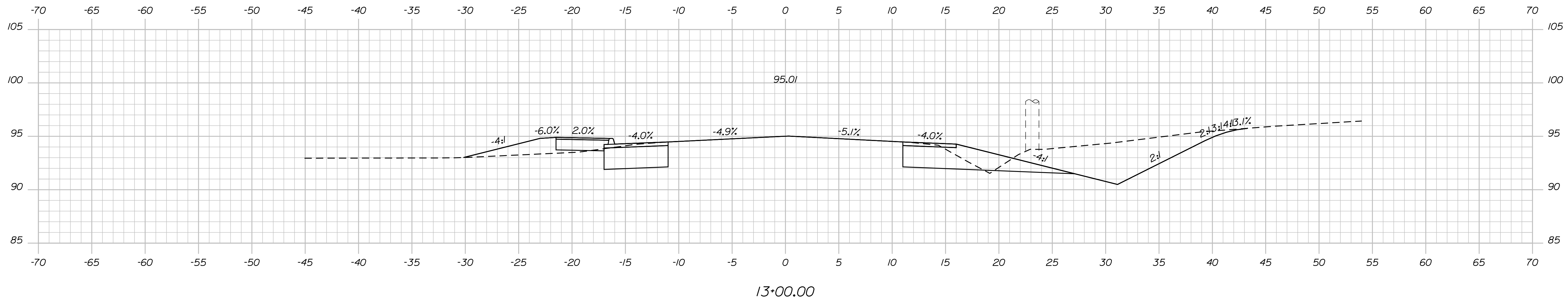
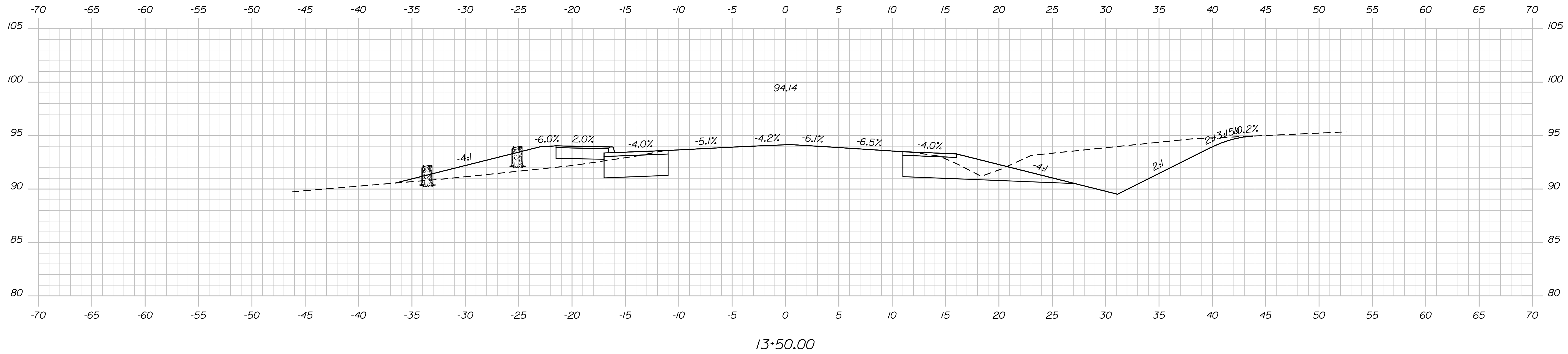

WORKING CROSS SECTIONS -
MODEL HAS NOT BEEN FULLY
DEVELOPED

STATE OF MAINE
DEPARTMENT OF TRANSPORTATION

ELIOT
ROUTE 103 YORK COUNTY

CROSS SECTIONS

SHEET NUMBER

OF 22

| DATE | BY | PROJ. MANAGER | CHECKED | DESIGNED | DESIGNED | REVISIONS | REVISIONS | REVISIONS | FIELD CHANGES |
|----------|------------|---------------|-----------|----------|----------|-----------|-----------|-----------|---------------|
| 06/20/23 | CHL LEM | J. BRUBAKER | T. WOLFEL | L. WEEK | | 1 | 2 | 3 | 4 |

| SIGNATURE | P.E. NUMBER | DATE |
|-----------|-------------|------|
| | | |

ELIOT ROUTE 103 YORK COUNTY CROSS SECTIONS

SHEET NUMBER OF 22

OS SHEET

Date: 7/21/2023

Username: twolfel

Division: HIGHWAY

Filename: ... \00\HIGHWAY\MSTA\sect.dgn

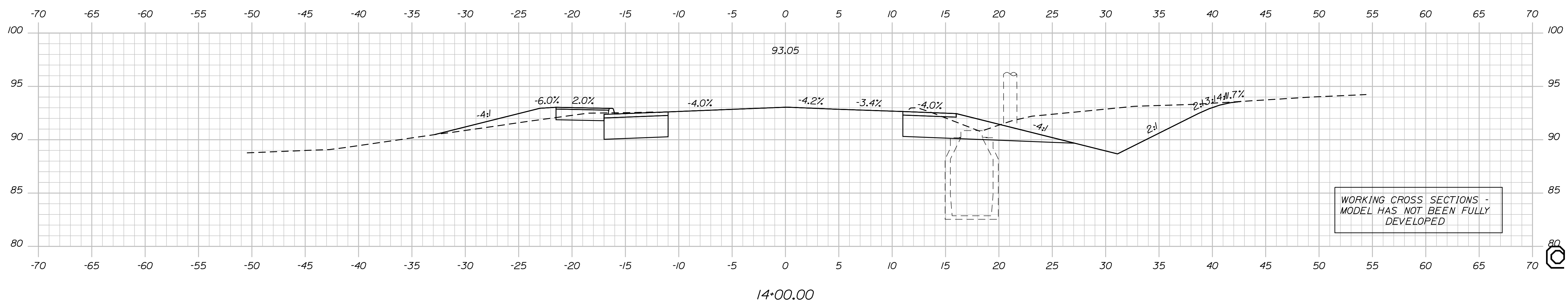
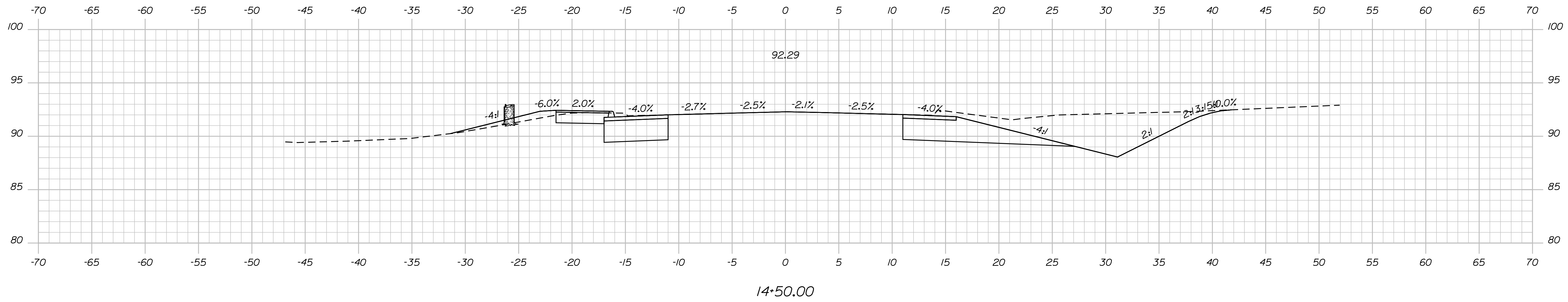
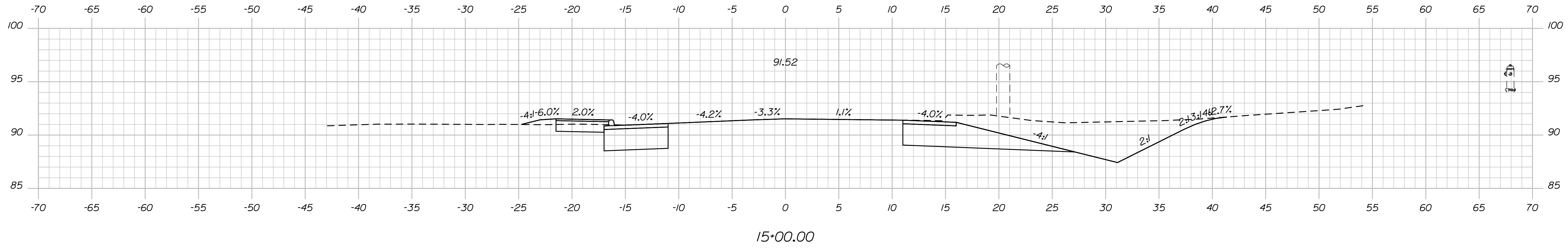

WORKING CROSS SECTIONS -
MODEL HAS NOT BEEN FULLY
DEVELOPED

STATE OF MAINE
DEPARTMENT OF TRANSPORTATION

ELIOT
ROUTE 103 YORK COUNTY

| PROJ. MANAGER | BY | DATE |
|-------------------|-----------|-------------|
| J. BRUBAKER | T. WOLFEL | 06/20/23 |
| CHECKED-REVIEWED | CHL | SIGNATURE |
| DESIGNED-DETAILED | LEM | P.E. NUMBER |
| DESIGNED-DETAILED | | DATE |
| REVISIONS 1 | | |
| REVISIONS 2 | | |
| REVISIONS 3 | | |
| REVISIONS 4 | | |
| FIELD CHANGES | | |

ELIOT
ROUTE 103 YORK COUNTY
CROSS SECTIONS

SHEET NUMBER

OS SHEET

OF 22

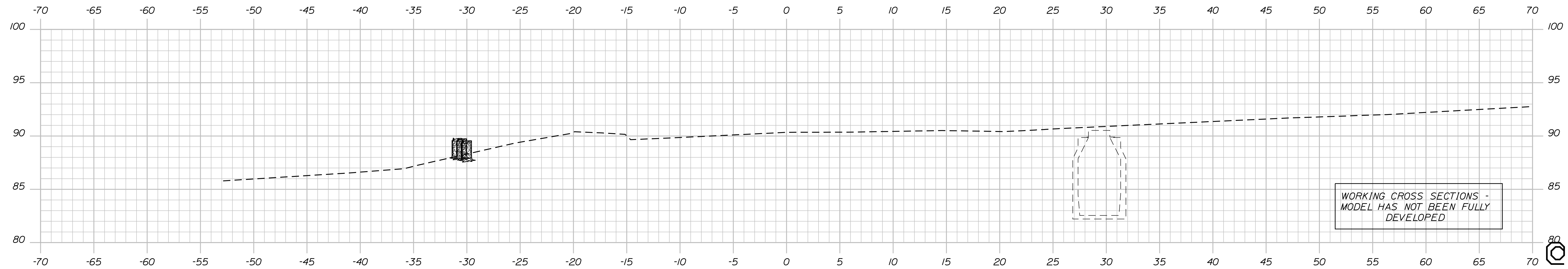

15+50.00

Sta. 15+50.00 to Sta. 15+50.00

STATE OF MAINE
DEPARTMENT OF TRANSPORTATION

ELIOT ROUTE 103 YORK COUNTY
CROSS SECTIONS

SHEET NUMBER

OS SHEET

OF 22

| | |
|--|-------------|
| | SIGNATURE |
| | P.E. NUMBER |
| | DATE |

| PROJ. MANAGER | J. BRUBAKER | BY | DATE |
|------------------|-------------|-----|---------|
| DESIGN DETAILED | T. WOLFEL | CHL | |
| CHECKED/REVIEWED | L. WEEK | LEM | 06/2023 |
| DESIGNS DETAILED | | | |
| REVISIONS 1 | | | |
| REVISIONS 2 | | | |
| REVISIONS 3 | | | |
| REVISIONS 4 | | | |
| FIELD CHANGES | | | |

HIGHWAY PLANS

Date: 7/21/2023

Username: twolfel

Division: HIGHWAY

Filename: ... \00\HIGHWAY\MSTA\sect.dgn

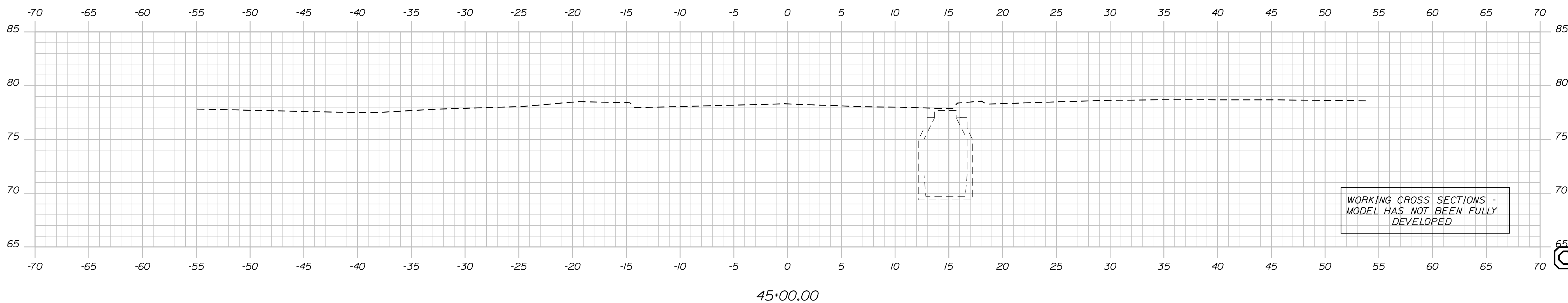
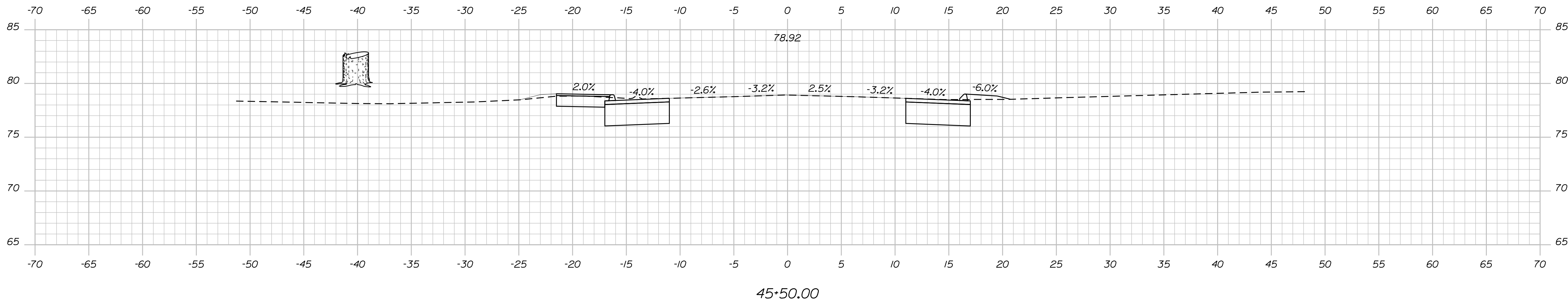
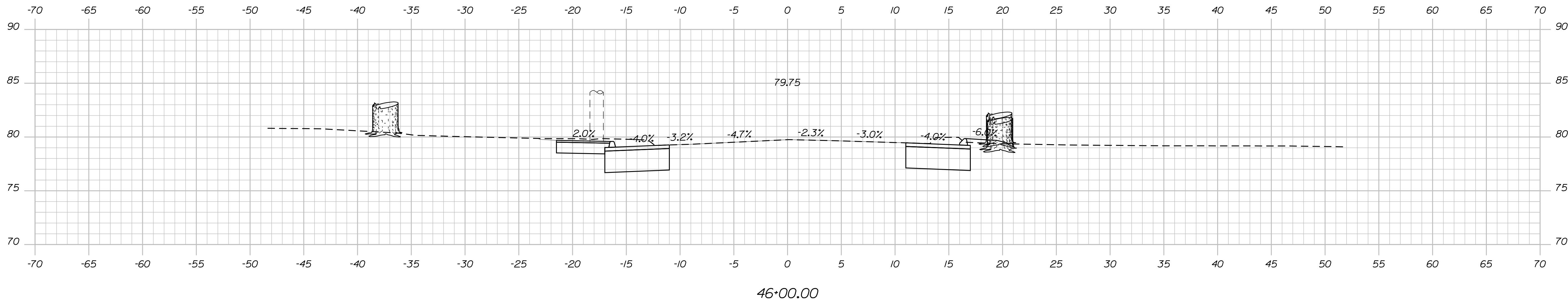

STATE OF MAINE
DEPARTMENT OF TRANSPORTATION

HIGHWAY PLANS

SIGNATURE

DATE

BY

J. BRUBAKER
T. WOLFEL
L. MEEK

DESIGN-DETAILED
CHECKED-REVIEWED
DESIGN-DETAILED

REVISIONS 1
REVISIONS 2
REVISIONS 3
REVISIONS 4
FIELD CHANGES

DATE

DATE

DATE

DATE

DATE

DATE

DATE

DATE

DATE

DATE

DATE

DATE

DATE

DATE

DATE

ELIOT ROUTE 10 YORK COUNTY

CROSS SECTIONS

SHEET NUMBER

OS SHEET

OF 22

Sta. 45+00.00 to Sta. 46+00.00

Date: 7/21/2023

Username: twolfel

Division: HIGHWAY

Filename: ... \00\HIGHWAY\MSTA\sect.dgn

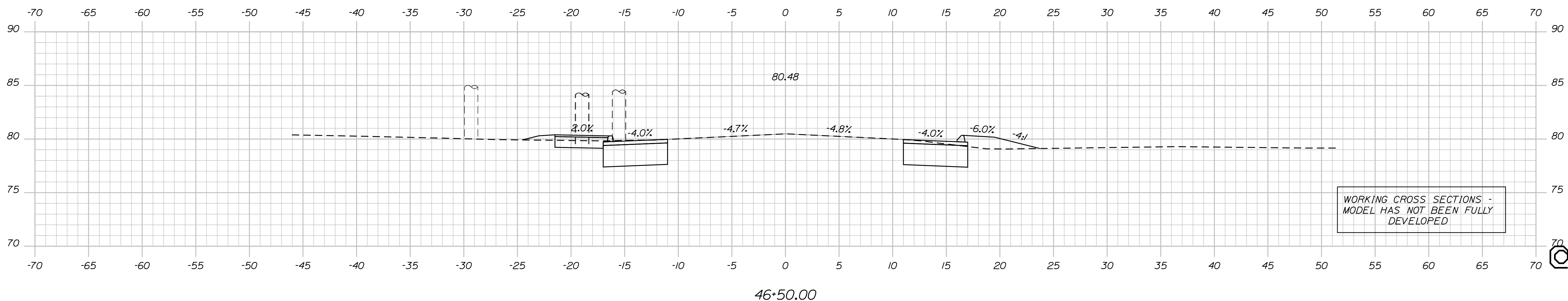
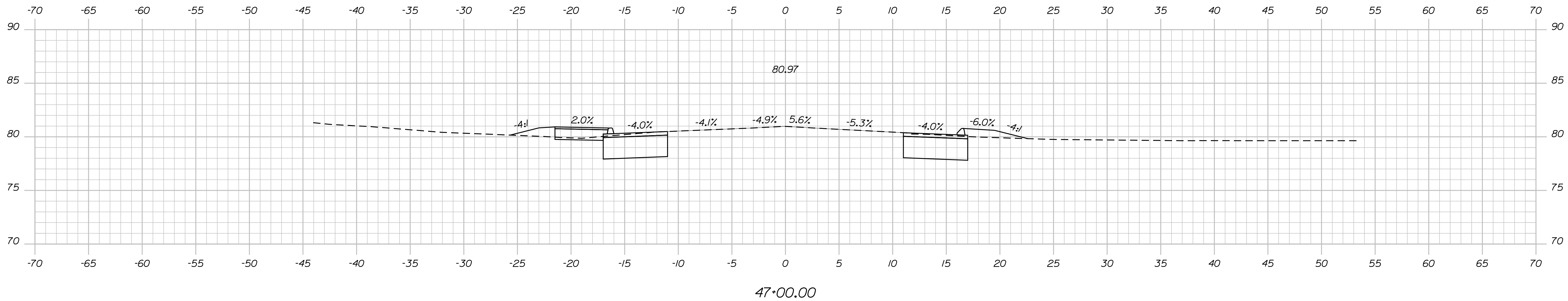
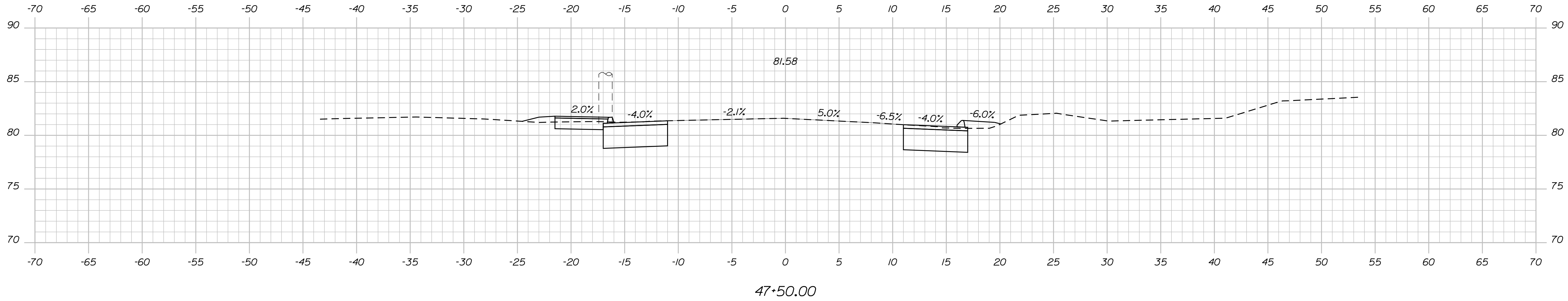

WORKING CROSS SECTIONS -
 MODEL HAS NOT BEEN FULLY
 DEVELOPED

STATE OF MAINE
 DEPARTMENT OF TRANSPORTATION

ELIOT
 ROUTE 103 YORK COUNTY

CROSS SECTIONS

SHEET NUMBER

OF 22

| | | |
|------------------|-----|-------------|
| DESIGN/DATE | CHL | SIGNATURE |
| CHECKED/REVIEWED | LEM | P.E. NUMBER |
| DESIGN/DATE | | DATE |
| REVISIONS 1 | | |
| REVISIONS 2 | | |
| REVISIONS 3 | | |
| REVISIONS 4 | | |
| FIELD CHANGES | | |

| | |
|---------------|-------------|
| PROJ. MANAGER | J. BRUBAKER |
| BY | T. WOLFEL |
| DATE | 06/2023 |

| |
|------------------------------|
| STATE OF MAINE |
| DEPARTMENT OF TRANSPORTATION |
| ELIOT |
| ROUTE 103 YORK COUNTY |
| CROSS SECTIONS |
| SHEET NUMBER |
| OF 22 |

HIGHWAY PLANS

Date: 7/21/2023

Username: twolfel

Division: HIGHWAY

Filename: ... \00\HIGHWAY\MSTA\sect.dgn

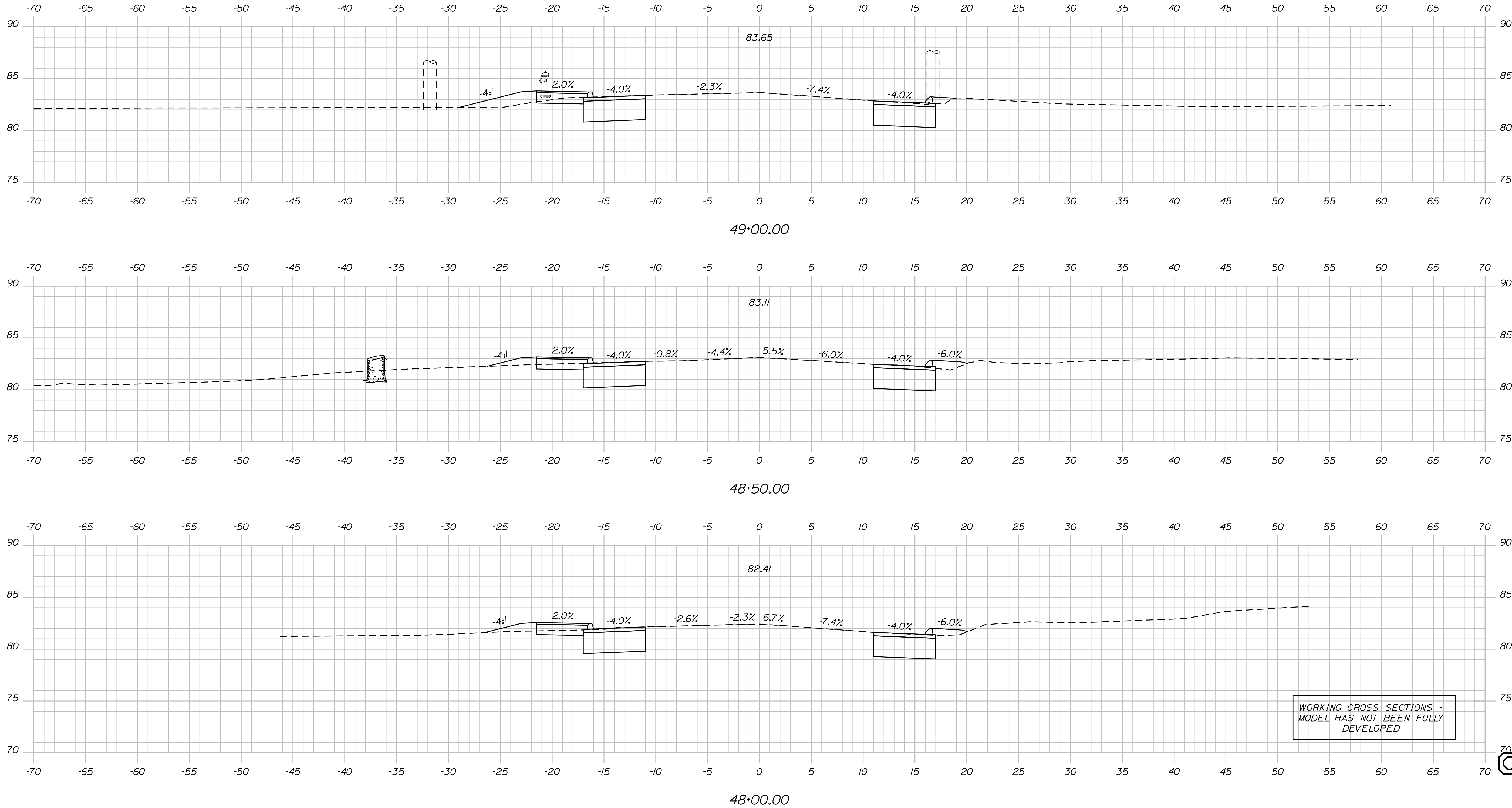

STATE OF MAINE
DEPARTMENT OF TRANSPORTATION

SIGNATURE

DATE

| PROJ. MANAGER | BY | DATE |
|-------------------|-----------|----------|
| J. BRUBAKER | T. WOLFEL | 06/20/23 |
| DESIGNED/DETAILED | CHL | |
| CHECKED/REVIEWED | LEM | |
| DESIGNED/DETAILED | | |
| REVISIONS 1 | | |
| REVISIONS 2 | | |
| REVISIONS 3 | | |
| REVISIONS 4 | | |
| FIELD CHANGES | | |

ELIOT ROUTE 103 YORK COUNTY

CROSS SECTIONS

SHEET NUMBER

OS SHEET

OF 22

Sta. 48+00.00 to Sta. 49+00.00

Date: 7/21/2023

Username: twolfel

Division: HIGHWAY

Filename: ... \00\HIGHWAY\MSTA\sect.dgn

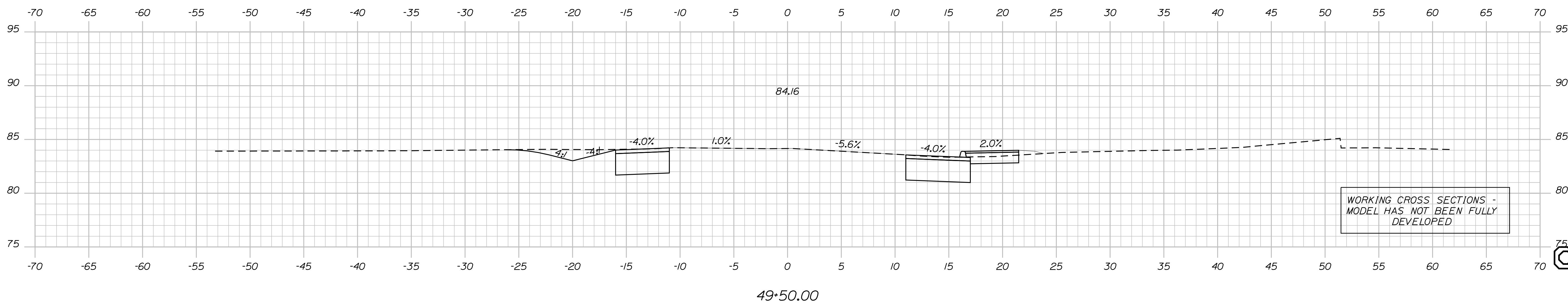
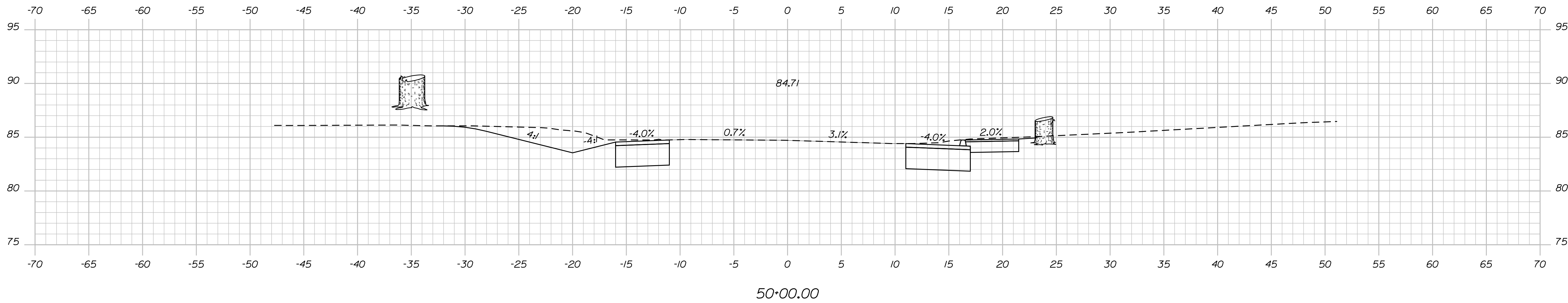
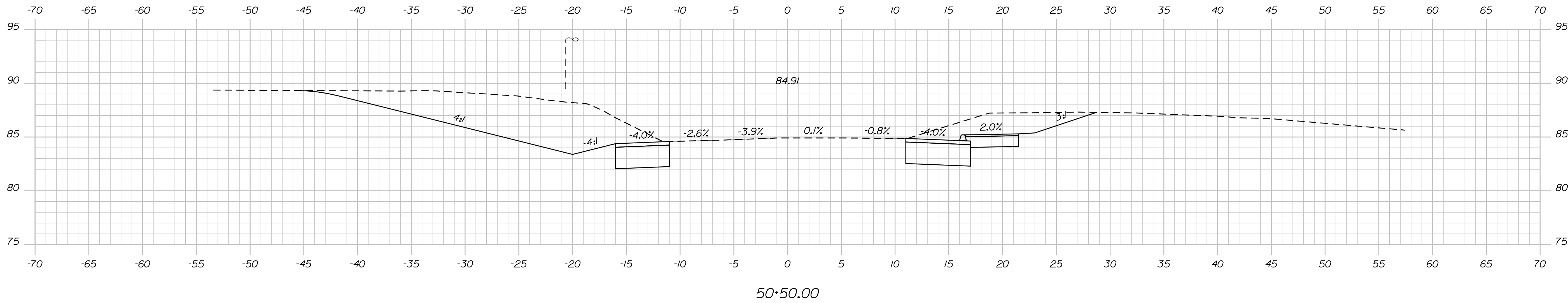

STATE OF MAINE
DEPARTMENT OF TRANSPORTATION

ELIOT
ROUTE 103 YORK COUNTY

CROSS SECTIONS

SHEET NUMBER

OF 22

HIGHWAY PLANS

SIGNATURE

DATE

BY

DATE

PROJ. MANAGER

CHECKED-REVIEWED

DESIGN-DETAILED

DESIGN-DETAILED

REVISIONS 1

REVISIONS 2

REVISIONS 3

REVISIONS 4

FIELD CHANGES

J. BRUBAKER

T. WOLFEL

L. WOLFEL

L. WOLFEL

06/2023

06/2023

06/2023

06/2023

OS SHEET

Date: 7/21/2023

Username: twolfel

Division: HIGHWAY

Filename: ... \00\HIGHWAY\MSTA\sect.dgn

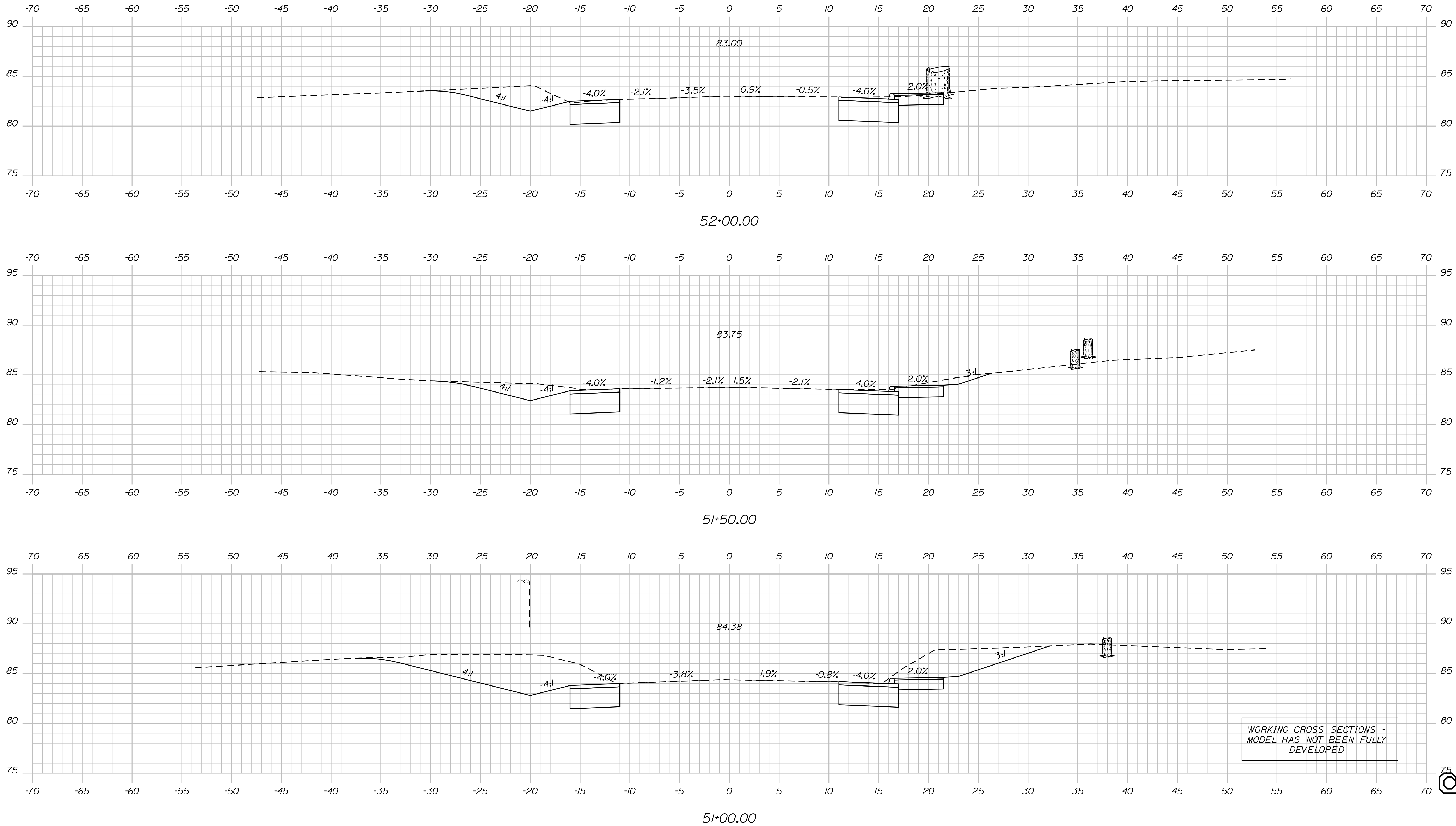

STATE OF MAINE
DEPARTMENT OF TRANSPORTATION

HIGHWAY PLANS

DESIGN DETAILED
CHECKED/REVIEWED
DESIGN DETAILED
REVISIONS 1
REVISIONS 2
REVISIONS 3
REVISIONS 4
FIELD CHANGES

| PROJ. MANAGER | J. BRUBAKER | BY | DATE |
|------------------|-------------|-----|---------|
| DESIGN DETAILED | T. WOLFEL | CHL | 06/2023 |
| CHECKED/REVIEWED | L. MEEK | LEM | |
| DESIGN DETAILED | | | |
| REVISIONS 1 | | | |
| REVISIONS 2 | | | |
| REVISIONS 3 | | | |
| REVISIONS 4 | | | |
| FIELD CHANGES | | | |

ELIOT
ROUTE 103 YORK COUNTY

CROSS SECTIONS

SHEET NUMBER

3 OF SHEET

OF 22

Sta. 51+00.00 to Sta. 52+00.00

Date: 7/21/2023

Username: twolfel

Division: HIGHWAY

Filename: ... \00\HIGHWAY\MSTA\sect.dgn

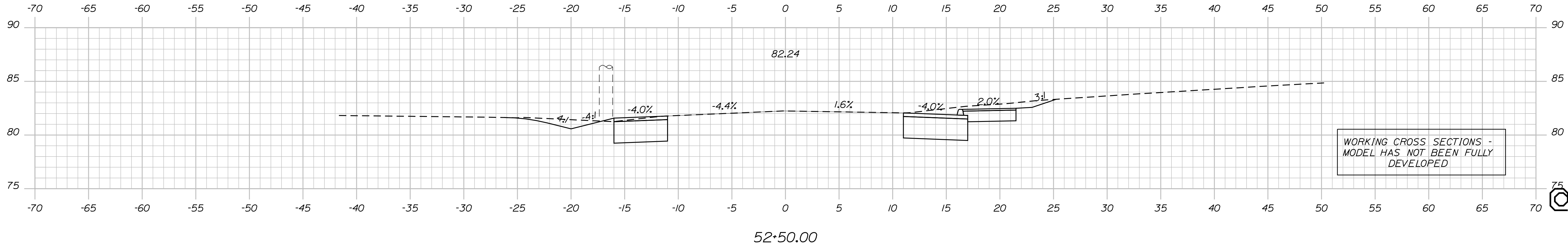
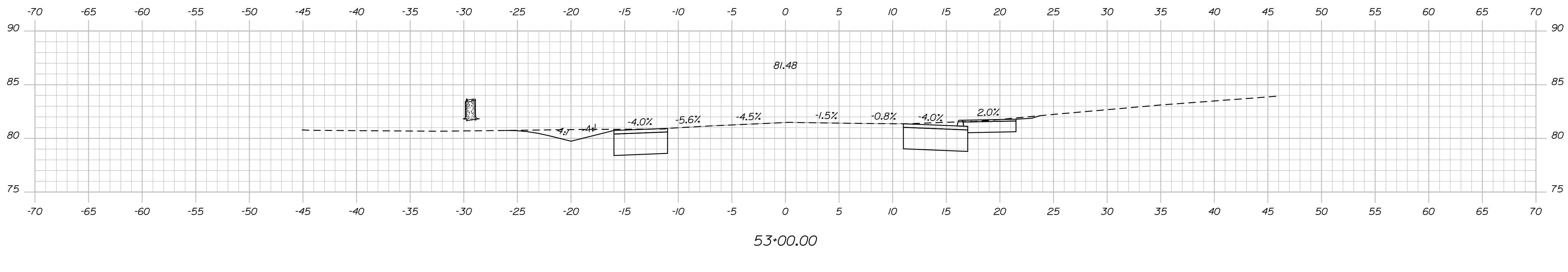
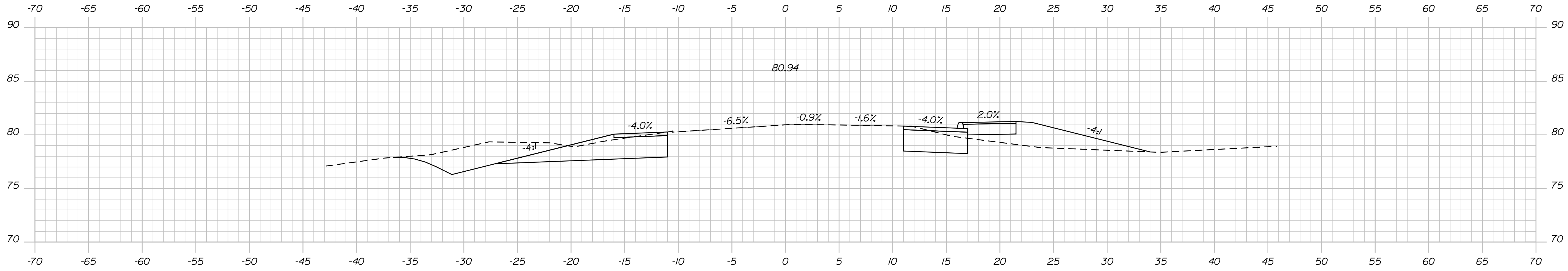

WORKING CROSS SECTIONS -
MODEL HAS NOT BEEN FULLY
DEVELOPED

STATE OF MAINE
DEPARTMENT OF TRANSPORTATION

SIGNATURE
P.E. NUMBER
DATE

| PROJ. MANAGER | BY | DATE |
|------------------|-----|----------|
| J. BRUBAKER | CHL | 06/20/23 |
| DESIGN-DETAILED | LEM | |
| CHECKED-REVIEWED | | |
| DESIGN-DETAILED | | |
| REVISIONS 1 | | |
| REVISIONS 2 | | |
| REVISIONS 3 | | |
| REVISIONS 4 | | |
| FIELD CHANGES | | |

ELIOT ROUTE 10 YORK COUNTY
CROSS SECTIONS

SHEET NUMBER

OF SHEET

OF 22

Date: 7/21/2023

Username: twolfel

Division: HIGHWAY

Filename: ... \00\HIGHWAY\MSTA\sect.dgn

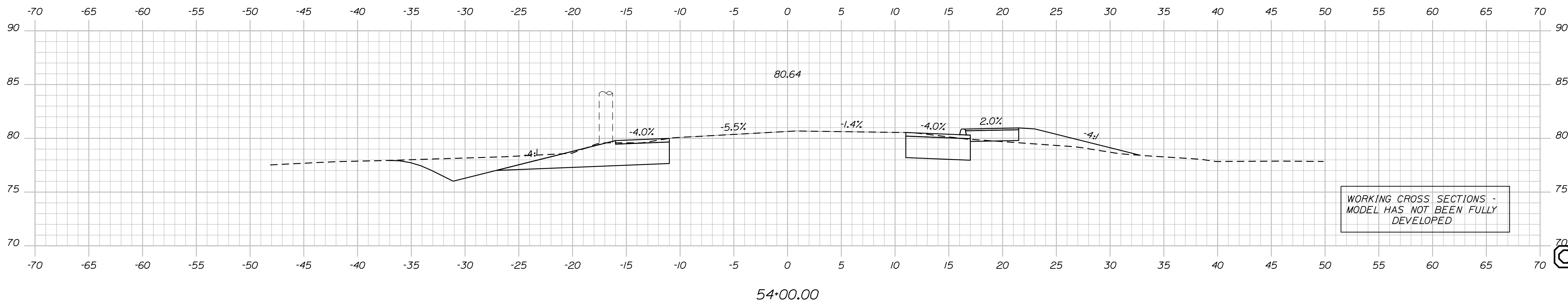
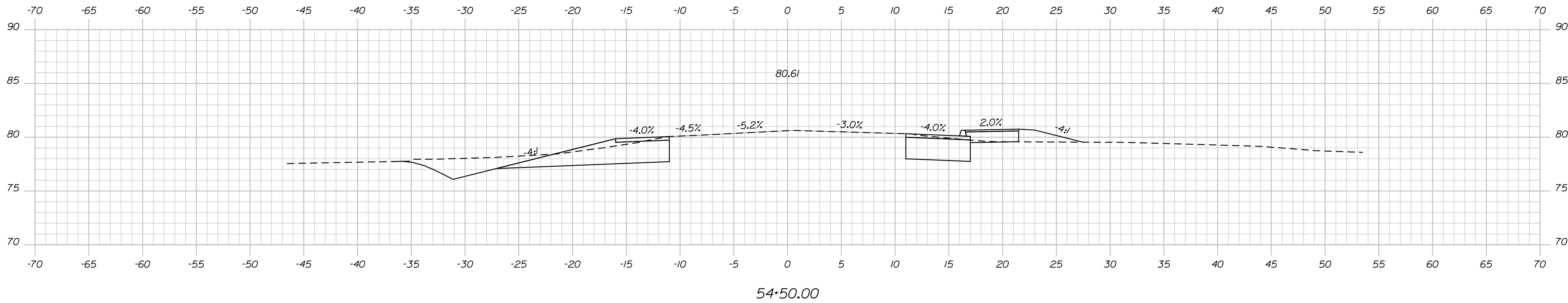
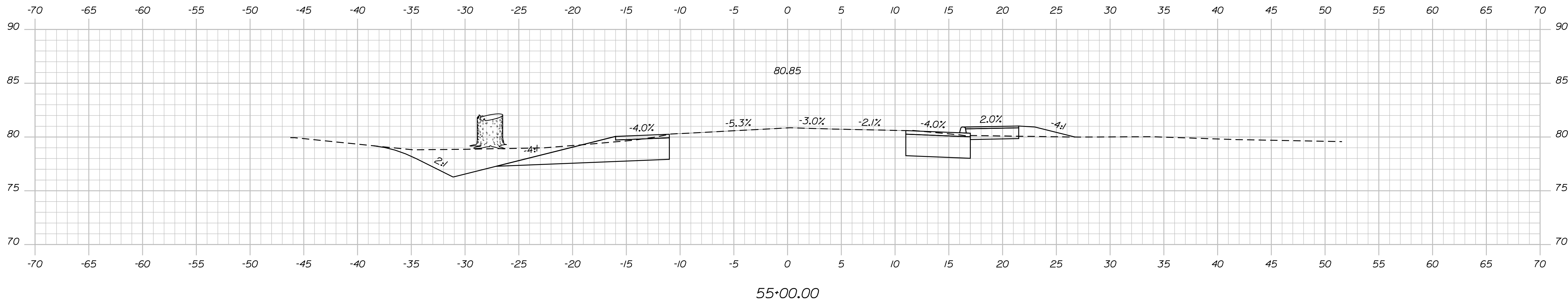

WORKING CROSS SECTIONS -
MODEL HAS NOT BEEN FULLY
DEVELOPED

STATE OF MAINE
DEPARTMENT OF TRANSPORTATION

ELIOT
ROUTE 103 YORK COUNTY

CROSS SECTIONS

SHEET NUMBER

OF 22

| | | |
|------------------|-------------|---------------|
| DESIGN DETAILED | J. BRUBAKER | PROJ. MANAGER |
| CHECKED/REVIEWED | T. WOLFEL | BY |
| DESIGN DETAILED | L. MEEK | DATE |
| REVISIONS 1 | CHL | SIGNATURE |
| REVISIONS 2 | LEM | P.E. NUMBER |
| REVISIONS 3 | | DATE |
| REVISIONS 4 | | |
| FIELD CHANGES | | |

| | |
|-------------|----------|
| DATE | 06/20/23 |
| SIGNATURE | |
| P.E. NUMBER | |
| DATE | |

| |
|------------------------------|
| STATE OF MAINE |
| DEPARTMENT OF TRANSPORTATION |
| ELIOT |
| ROUTE 103 YORK COUNTY |
| CROSS SECTIONS |
| SHEET NUMBER |
| OF 22 |

HIGHWAY PLANS

Date: 7/21/2023

Username: twolfel

Division: HIGHWAY

Filename: ... \00\HIGHWAY\MSTA\sect.dgn

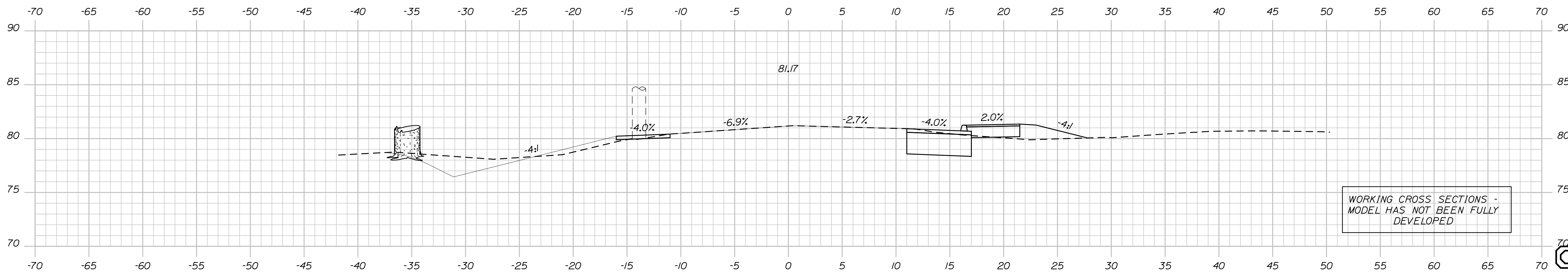
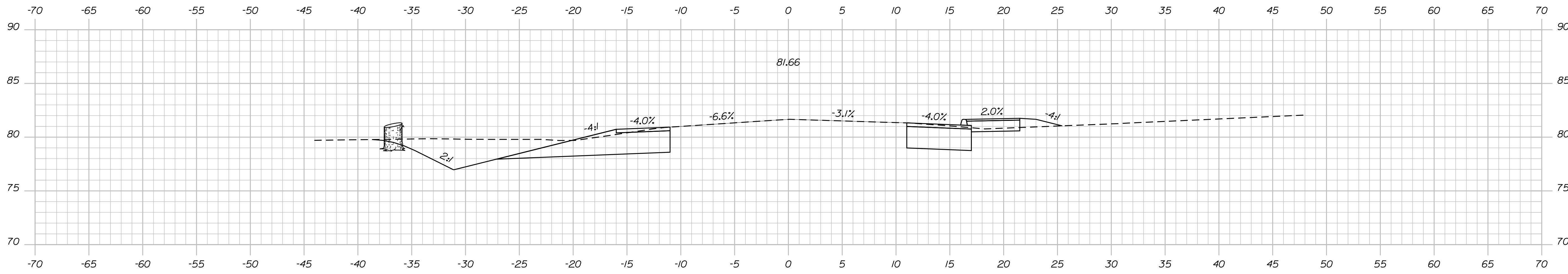
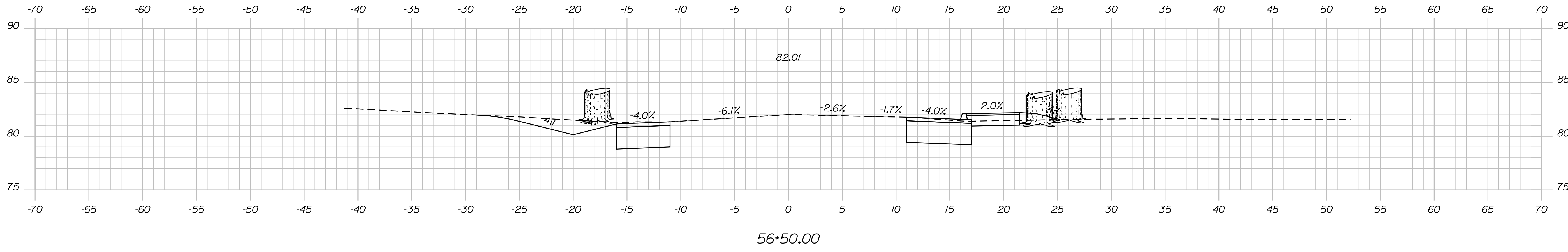

WORKING CROSS SECTIONS -
MODEL HAS NOT BEEN FULLY
DEVELOPED

STATE OF MAINE
DEPARTMENT OF TRANSPORTATION

ELIOT
ROUTE 103 YORK COUNTY

| PROJ. MANAGER | BY | DATE |
|---------------|-----------|---------|
| J. BRUBAKER | T. WOLFEL | 06/2023 |

| DESIGN DETAILED | CHECKED | REVIEWED | DATE |
|-----------------|---------|----------|------|
| LEM | LEM | | |

SHEET NUMBER
OF 22

OS SHEET

Sta. 55+50.00 to Sta. 56+50.00

Date: 7/21/2023

Username: twolfel

Division: HIGHWAY

Filename: ... \00\HIGHWAY\MSTA\sect.dgn

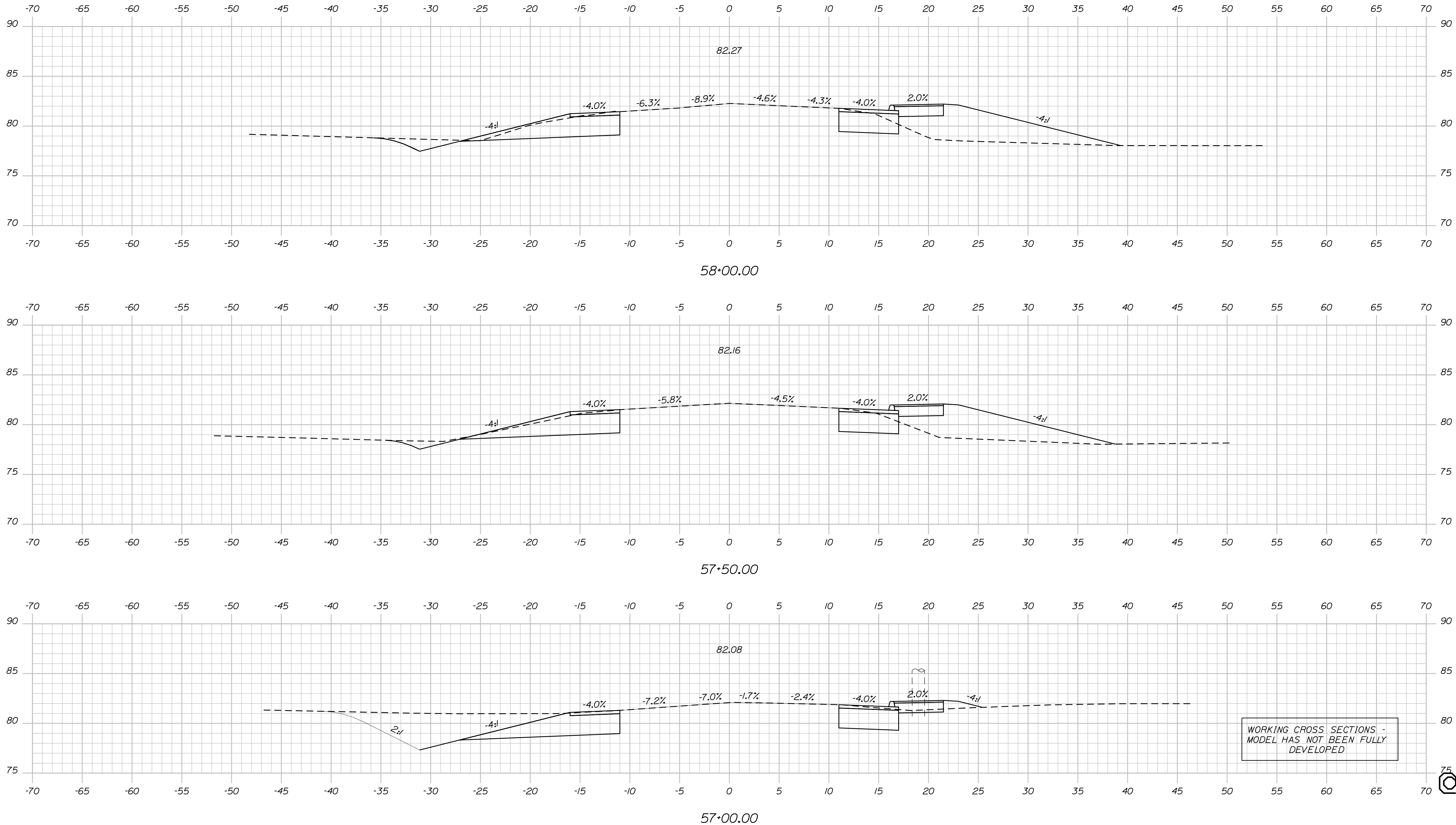

WORKING CROSS SECTIONS -
MODEL HAS NOT BEEN FULLY
DEVELOPED

STATE OF MAINE
DEPARTMENT OF TRANSPORTATION

ELIOT
ROUTE 103 YORK COUNTY
CROSS SECTIONS

SHEET NUMBER

OF SHEET

OF 22

Sta. 57+00.00 to Sta. 58+00.00

| PROJ. MANAGER | BY | DATE | SIGNATURE | P.E. NUMBER | DATE |
|------------------|-----------|---------|-----------|-------------|------|
| J. BRUBAKER | T. WOLFEL | 06/2023 | | | |
| DESIGN DETAILED | CHK | | | | |
| CHECKED-REVIEWED | LEM | | | | |
| DESIGN DETAILED | | | | | |
| REVISIONS 1 | | | | | |
| REVISIONS 2 | | | | | |
| REVISIONS 3 | | | | | |
| REVISIONS 4 | | | | | |
| FIELD CHANGES | | | | | |

HIGHWAY PLANS

Date: 7/21/2023

Username: twolfel

Division: HIGHWAY

Filename: ... \00\HIGHWAY\MSTA\sect.dgn

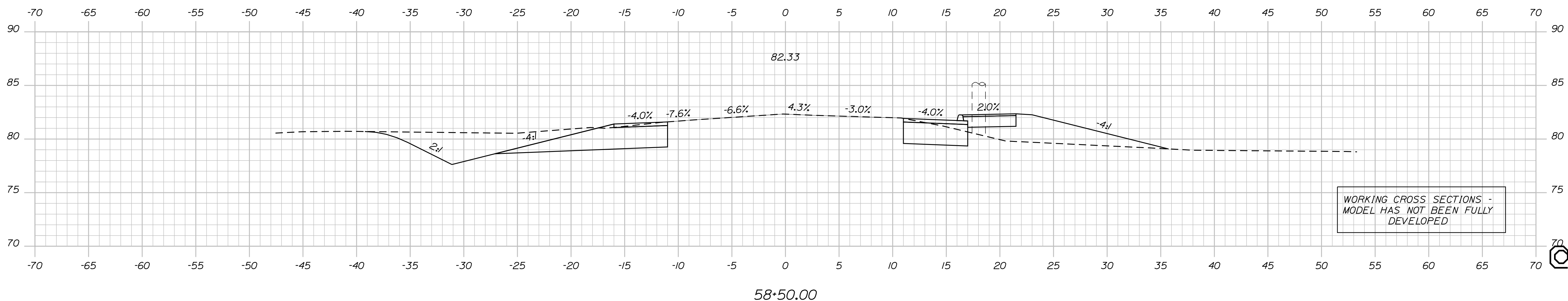
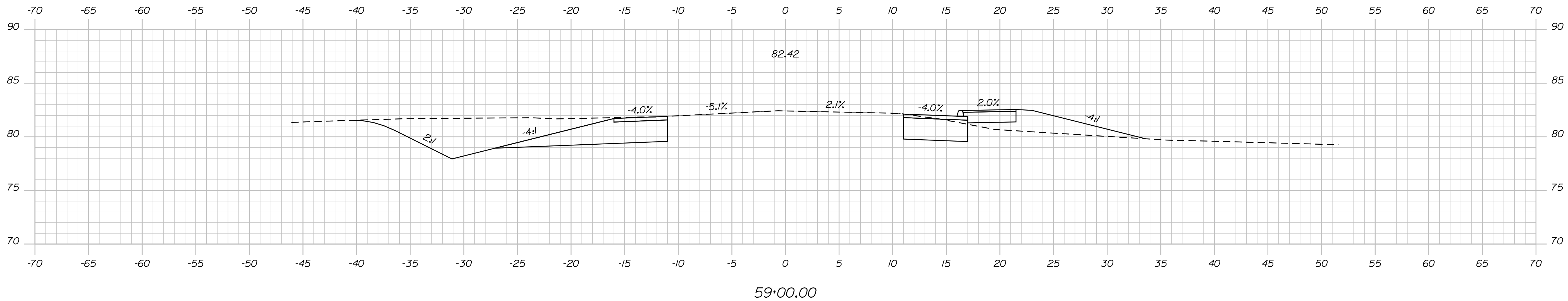
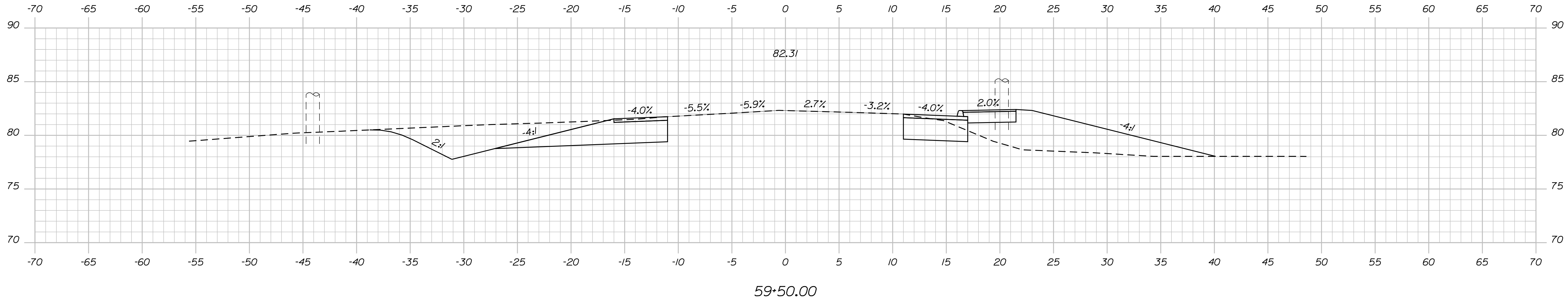

WORKING CROSS SECTIONS -
MODEL HAS NOT BEEN FULLY
DEVELOPED

STATE OF MAINE

DEPARTMENT OF TRANSPORTATION

HIGHWAY PLANS

DATE

06/2023

BY

CHL

PROJ. MANAGER

J. BRUBAKER

CHECKED

T. WOLFEL

DESIGNED

L. MEEK

DESIGNED

L. MEEK

REVISIONS

1

REVISIONS

2

REVISIONS

3

REVISIONS

4

FIELD CHANGES

SIGNATURE

P.E. NUMBER

DATE

ELIOT

ROUTE 103

YORK COUNTY

CROSS SECTIONS

SHEET NUMBER

OS SHEET

OF 22

Sta. 58+50.00 to Sta. 59+50.00

Date: 7/21/2023

Username: twolfel

Division: HIGHWAY

Filename: ... \00\HIGHWAY\MSTA\sect.dgn

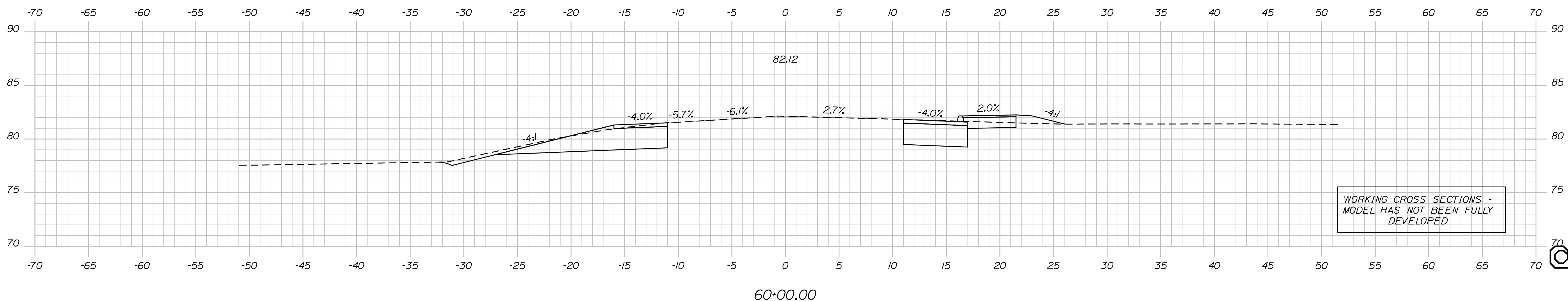
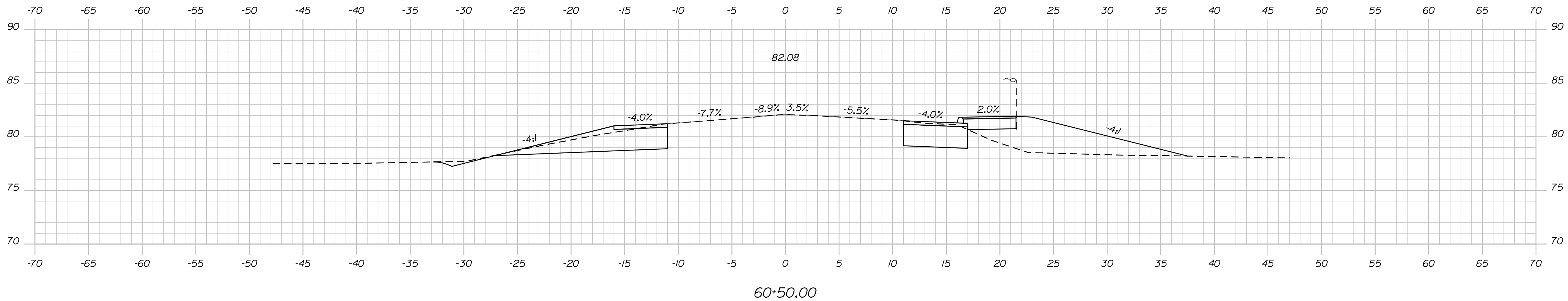
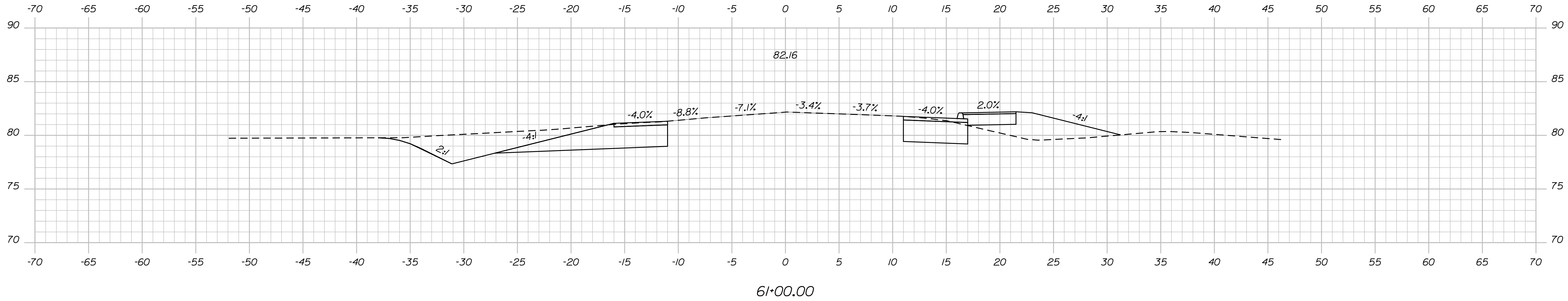

WORKING CROSS SECTIONS -
MODEL HAS NOT BEEN FULLY
DEVELOPED

STATE OF MAINE
DEPARTMENT OF TRANSPORTATION

ELIOT
ROUTE 103 YORK COUNTY

CROSS SECTIONS

PROJ. MANAGER: J. BRUBAKER
 CHECKED-REVIEWED: T. WOLFEL
 DESIGN-REVIEWED: L. MEEK
 DESIGN-REVIEWED: L. MEEK
 REVISIONS 1
 REVISIONS 2
 REVISIONS 3
 REVISIONS 4
 FIELD CHANGES

SHEET NUMBER
OF 22

OS SHEET

Date: 7/21/2023

Username: twolfel

Division: HIGHWAY

Filename: ... \00\HIGHWAY\MSTA\sect.dgn

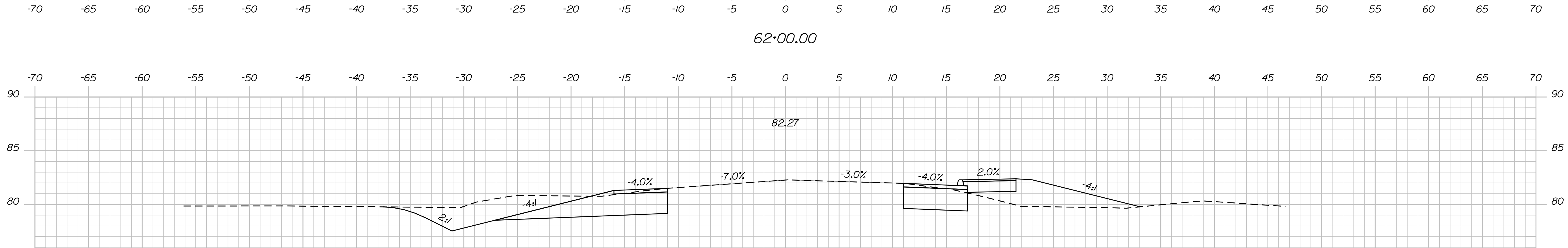
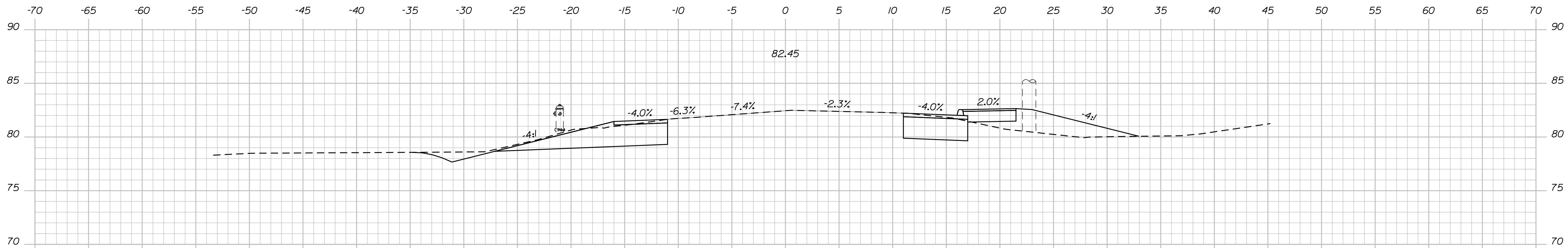
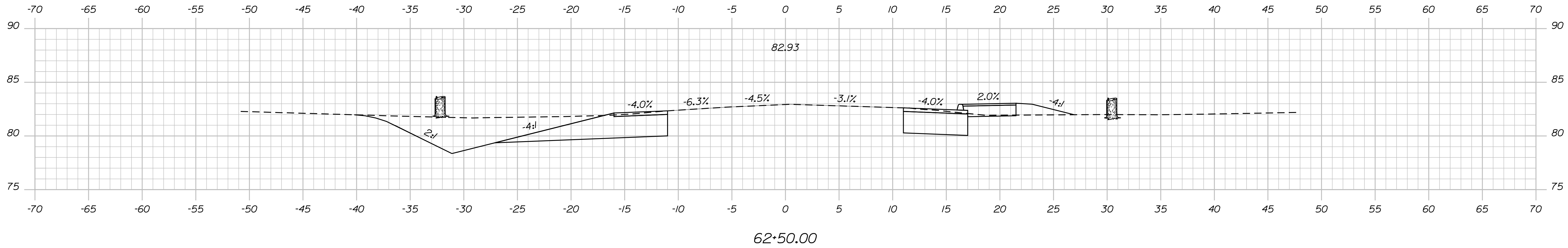

WORKING CROSS SECTIONS -
MODEL HAS NOT BEEN FULLY
DEVELOPED

STATE OF MAINE
DEPARTMENT OF TRANSPORTATION

ELIOT
ROUTE 103 YORK COUNTY

| PROJ. MANAGER | BY | DATE |
|------------------|-----------|-------------|
| J. BRUBAKER | T. WOLFEL | 06/2023 |
| CHECKED-REVIEWED | CHL | SIGNATURE |
| DESIGN-REVIEWED | LEM | P.E. NUMBER |
| DESIGN-REVIEWED | | DATE |
| REVISIONS 1 | | |
| REVISIONS 2 | | |
| REVISIONS 3 | | |
| REVISIONS 4 | | |
| FIELD CHANGES | | |

ELIOT
ROUTE 103 YORK COUNTY
CROSS SECTIONS

SHEET NUMBER

OF SHEET

OF 22

Sta. 61+50.00 to Sta. 62+50.00

Date: 7/21/2023

Username: twolfel

Division: HIGHWAY

Filename: ... \00\HIGHWAY\MSTA\vssect.dgn

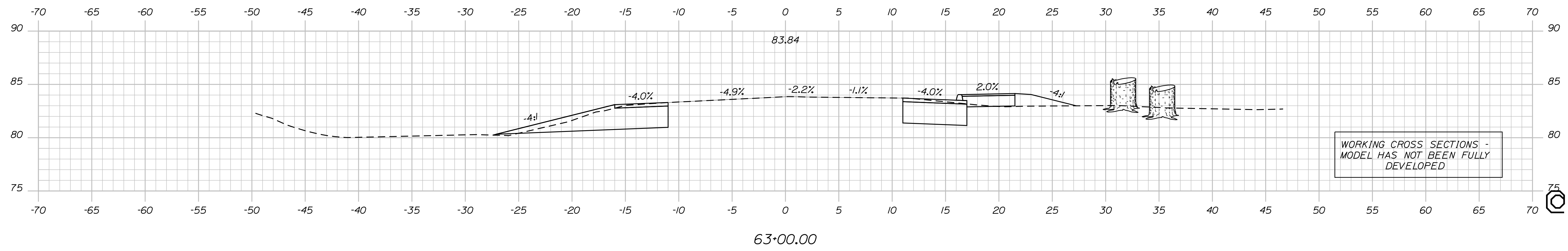
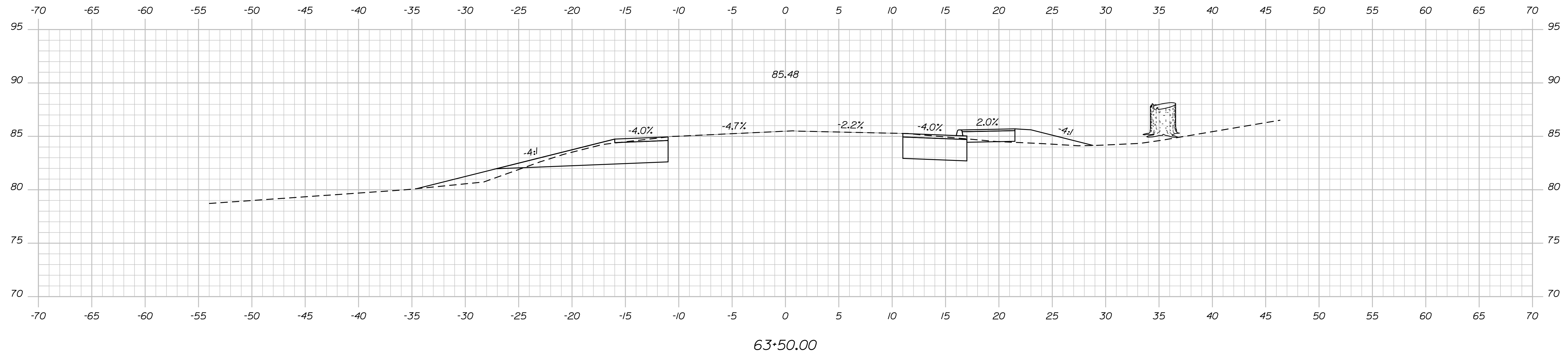
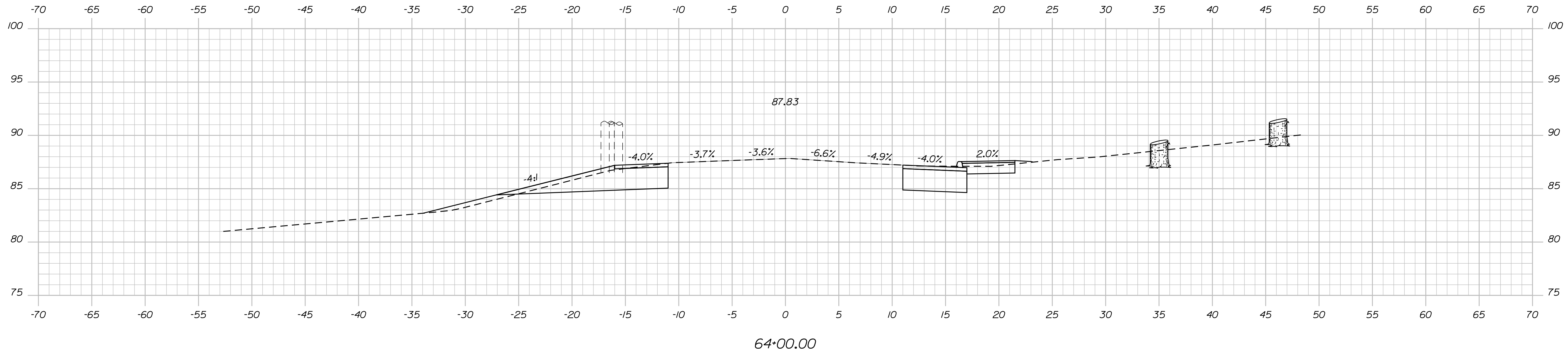

WORKING CROSS SECTIONS -
MODEL HAS NOT BEEN FULLY
DEVELOPED

STATE OF MAINE
DEPARTMENT OF TRANSPORTATION

ELIOT ROUTE 10 YORK COUNTY

CROSS SECTIONS

PROJ. MANAGER: J. BRUBAKER
 DESIGN-DETAILED: T. WOLFEL
 CHECKED-REVIEWED: L. MEEK
 DESIGNS-DETAILED: L. MEEK
 REVISIONS 1:
 REVISIONS 2:
 REVISIONS 3:
 REVISIONS 4:
 FIELD CHANGES:

SHEET NUMBER
OF 22

OS SHEET

Date: 7/21/2023

Username: twolfel

Division: HIGHWAY

Filename: ... \000\HIGHWAY\MSTA\wsect.dgn

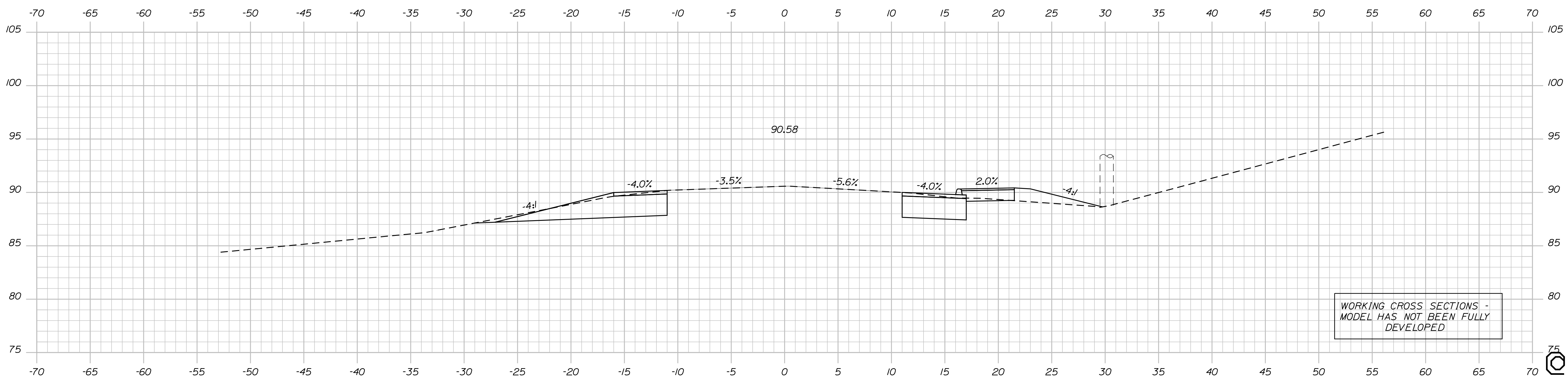
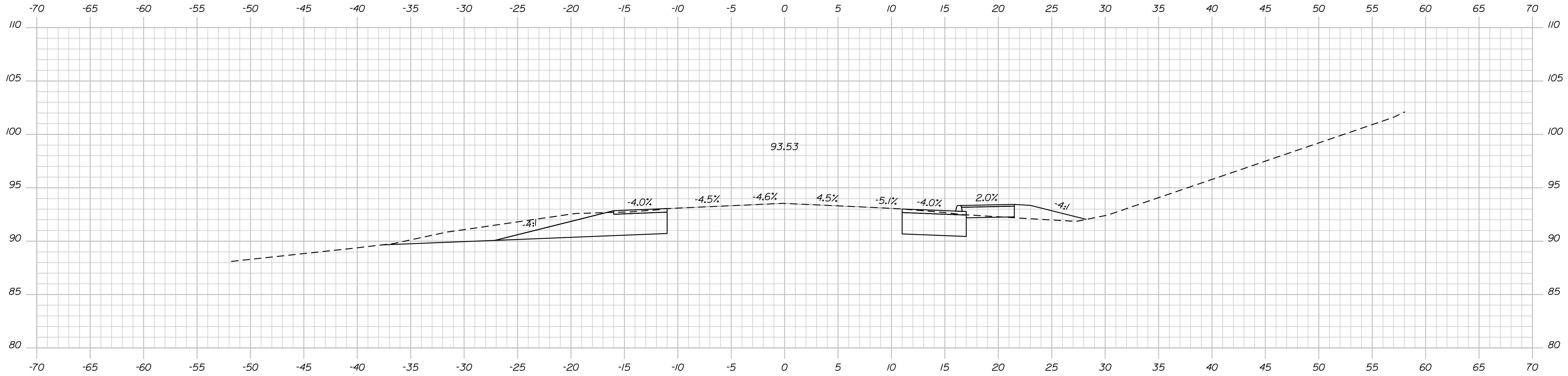

WORKING CROSS SECTIONS -
MODEL HAS NOT BEEN FULLY
DEVELOPED

STATE OF MAINE
DEPARTMENT OF TRANSPORTATION

ELIOT
ROUTE 103 YORK COUNTY

| PROJ. MANAGER | BY | DATE |
|---------------|-----|----------|
| J. BRUBAKER | CHL | 06/20/23 |
| T. WOLFEL | LEM | |
| L. MEEK | | |

CROSS SECTIONS

SHEET NUMBER
10
OF 22

Date: 7/21/2023

Username: twolfel

Division: HIGHWAY

Filename: ... \00\HIGHWAY\MSTA\sect.dgn

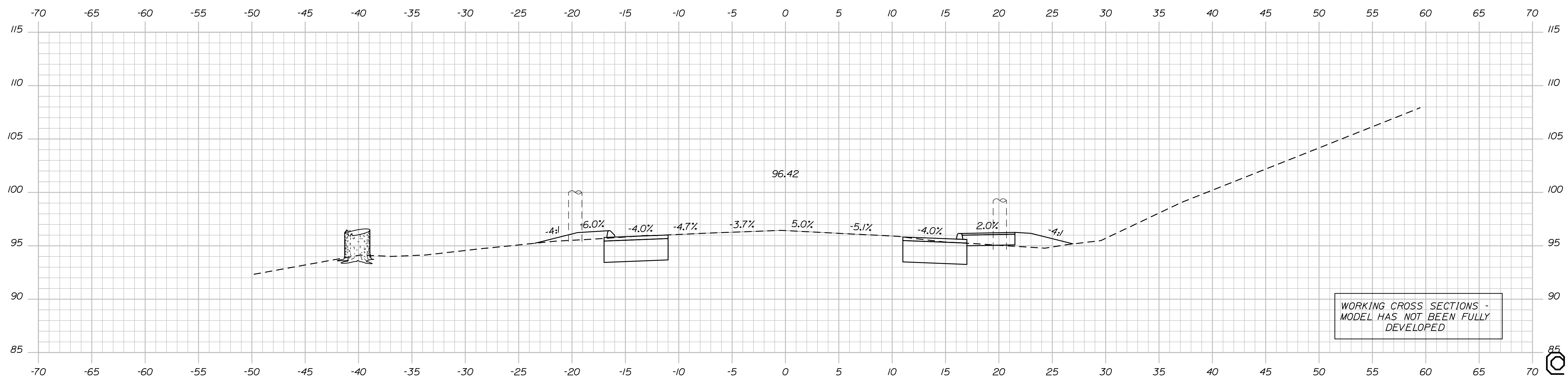
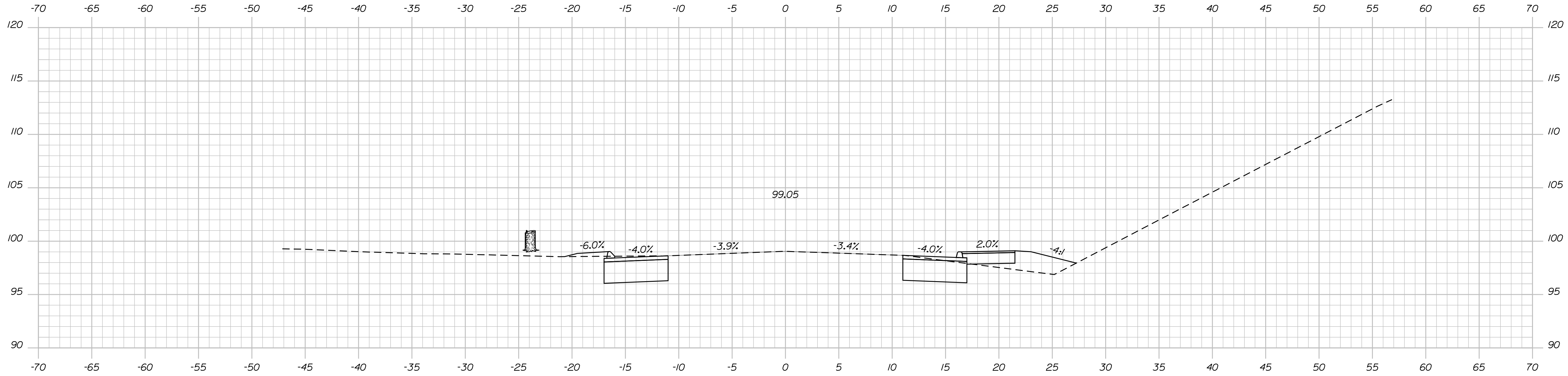

WORKING CROSS SECTIONS -
MODEL HAS NOT BEEN FULLY
DEVELOPED

STATE OF MAINE
DEPARTMENT OF TRANSPORTATION

ELIOT
ROUTE 103 YORK COUNTY

| PROJ. MANAGER | BY | DATE |
|------------------|-----------|-------------|
| J. BRUBAKER | T. WOLFEL | 06/2023 |
| CHECKED-REVIEWED | CHL | SIGNATURE |
| DESIGN DETAILED | LEM | P.E. NUMBER |
| DESIGN DETAILED | | DATE |
| REVISIONS 1 | | |
| REVISIONS 2 | | |
| REVISIONS 3 | | |
| REVISIONS 4 | | |
| FIELD CHANGES | | |

CROSS SECTIONS

SHEET NUMBER

OF SHEET

OF 22

Date: 7/21/2023

Username: twolfel

Division: HIGHWAY

Filename: ... \00\HIGHWAY\MSTA\sect.dgn

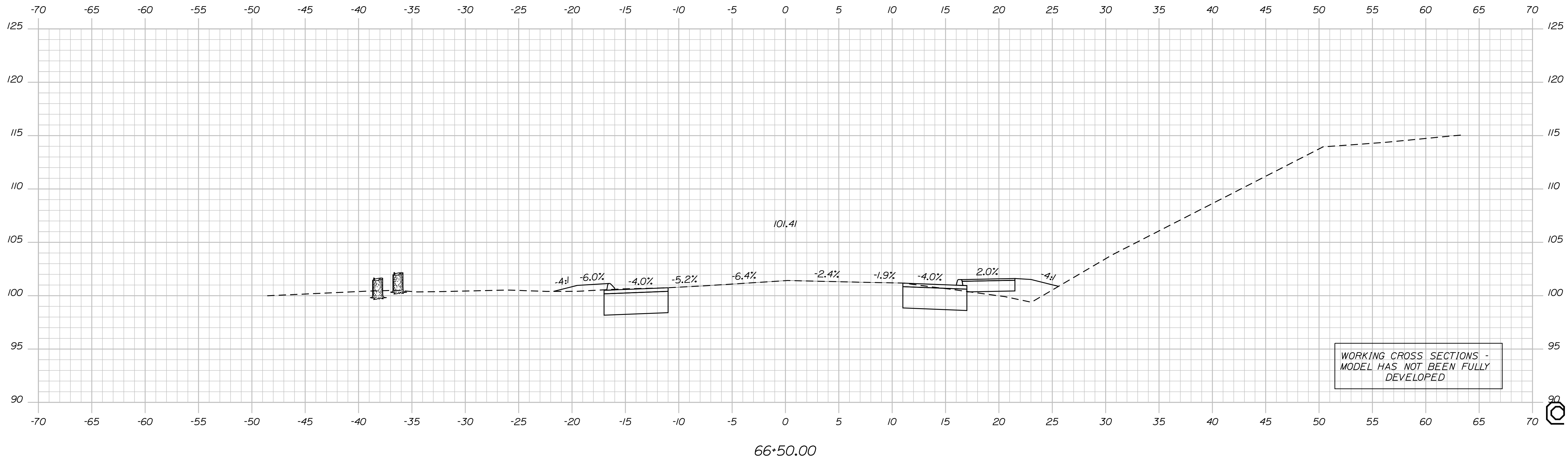
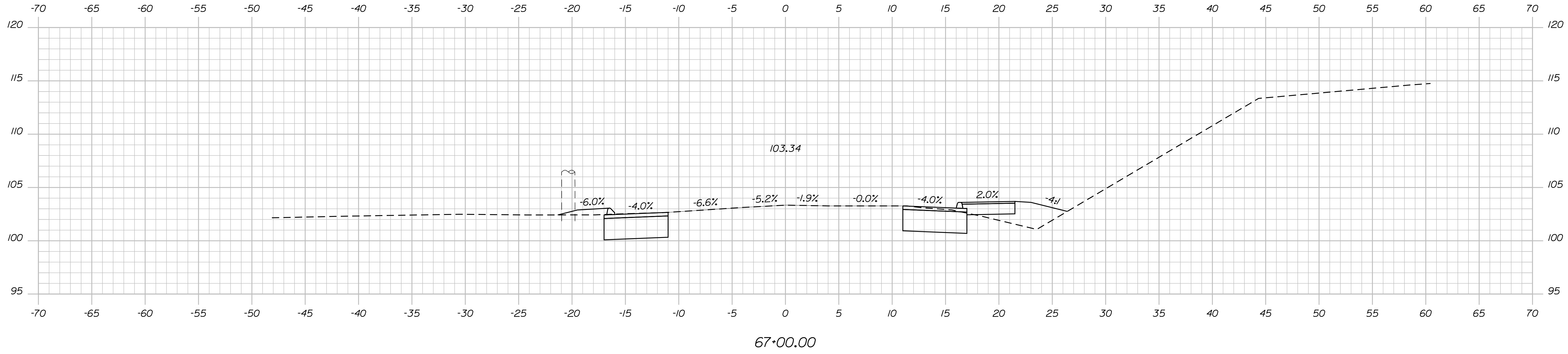

WORKING CROSS SECTIONS -
MODEL HAS NOT BEEN FULLY
DEVELOPED

STATE OF MAINE
DEPARTMENT OF TRANSPORTATION

ELIOT
ROUTE 103 YORK COUNTY

| PROJ. MANAGER | BY | DATE |
|------------------|-----|---------|
| J. BRUBAKER | CHL | 06/2023 |
| DESIGN-DETAILED | LEM | |
| CHECKED-REVIEWED | | |
| DESIGN-DETAILED | | |
| REVISIONS 1 | | |
| REVISIONS 2 | | |
| REVISIONS 3 | | |
| REVISIONS 4 | | |
| FIELD CHANGES | | |

ELIOT
ROUTE 103 YORK COUNTY
CROSS SECTIONS

SHEET NUMBER
10
OF 22

SHEET

Date: 7/21/2023

Username: twolfel

Division: HIGHWAY

Filename: ... \00\HIGHWAY\MSTA\sect.dgn

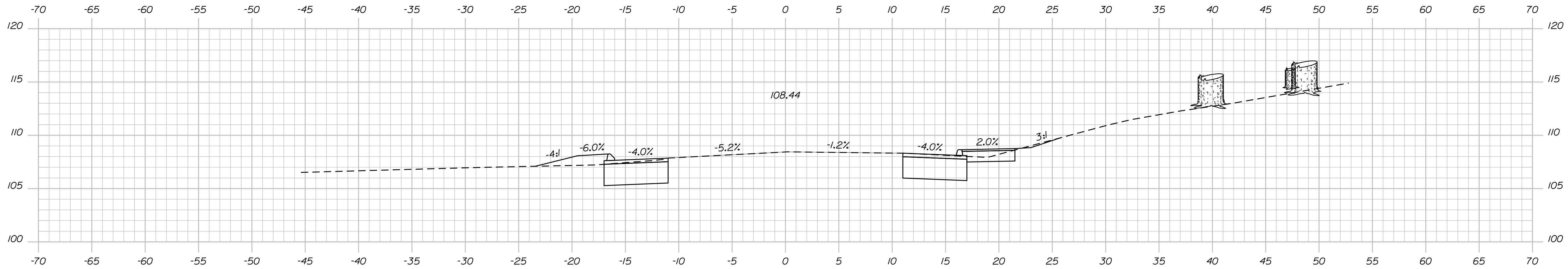

68+50.00

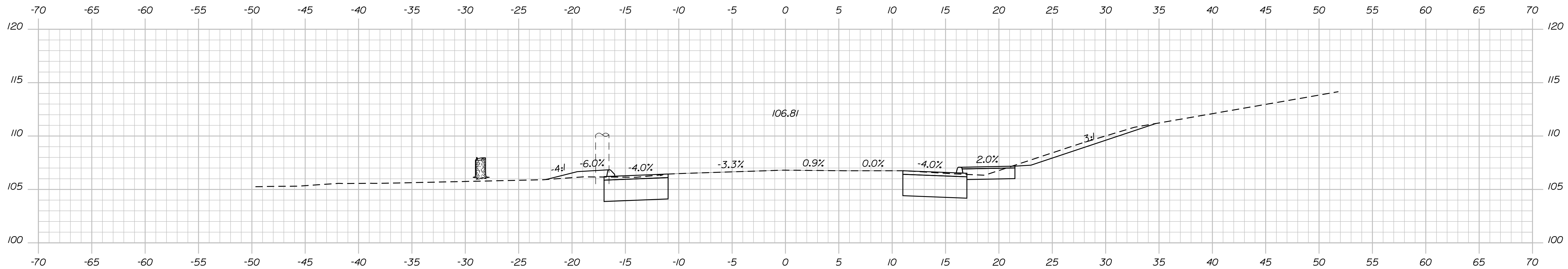

68+00.00

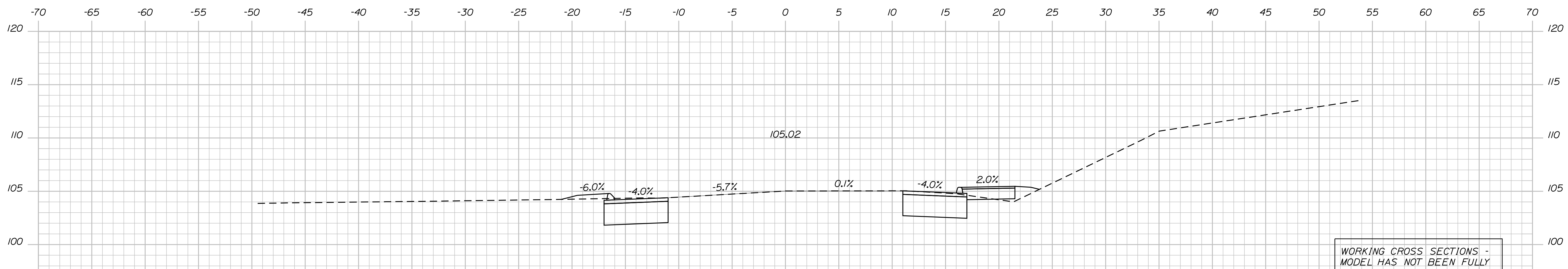

67+50.00

WORKING CROSS SECTIONS -
MODEL HAS NOT BEEN FULLY
DEVELOPED

STATE OF MAINE
DEPARTMENT OF TRANSPORTATION

HIGHWAY PLANS

DATE
06/2023

BY
J. BRUBAKER
T. WOLFEL
L. MEEK

DESIGN DETAILED
CHECKED-REVIEWED
DESIGN DETAILED
REVISIONS 1
REVISIONS 2
REVISIONS 3
REVISIONS 4
FIELD CHANGES

SIGNATURE
P.E. NUMBER
DATE

ELIOT
ROUTE 103 YORK COUNTY

CROSS SECTIONS

SHEET NUMBER

OF SHEET

OF 22

Sta. 67+50.00 to Sta. 68+50.00

Date: 7/21/2023

Username: twolfel

Division: HIGHWAY

Filename: ... \00\HIGHWAY\MSTA\sect.dgn

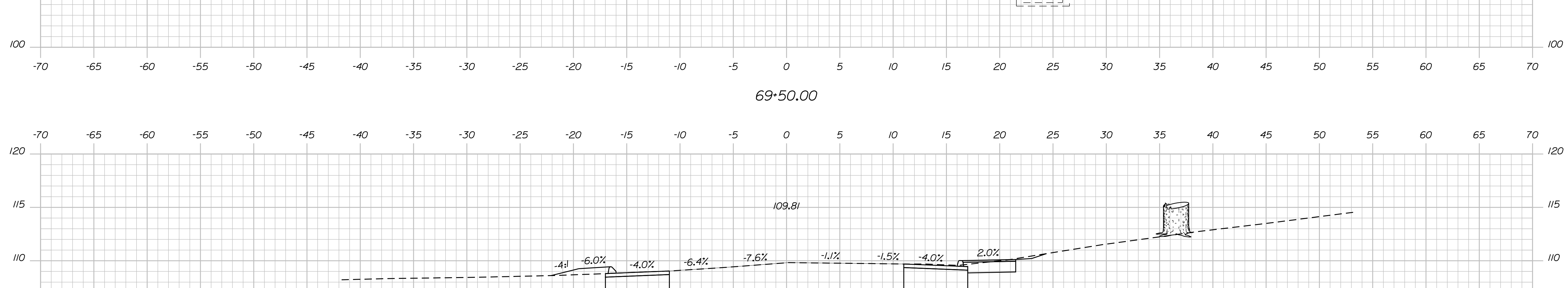
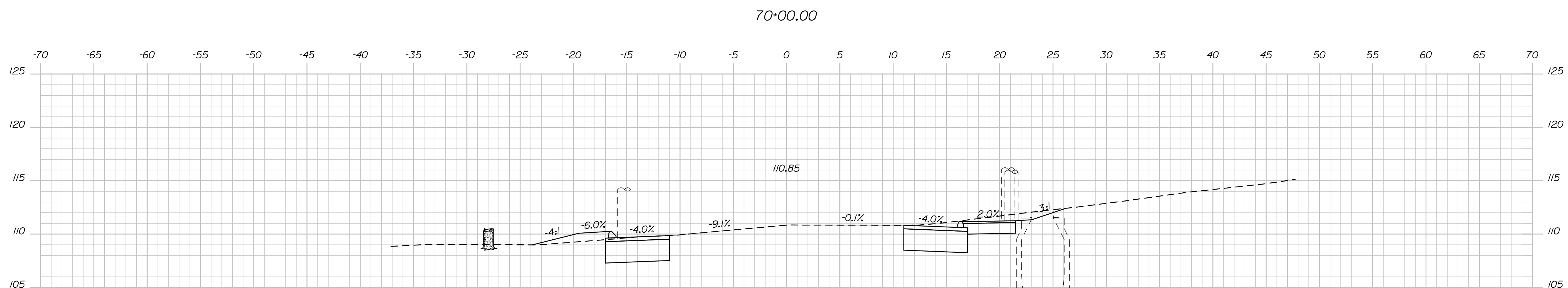
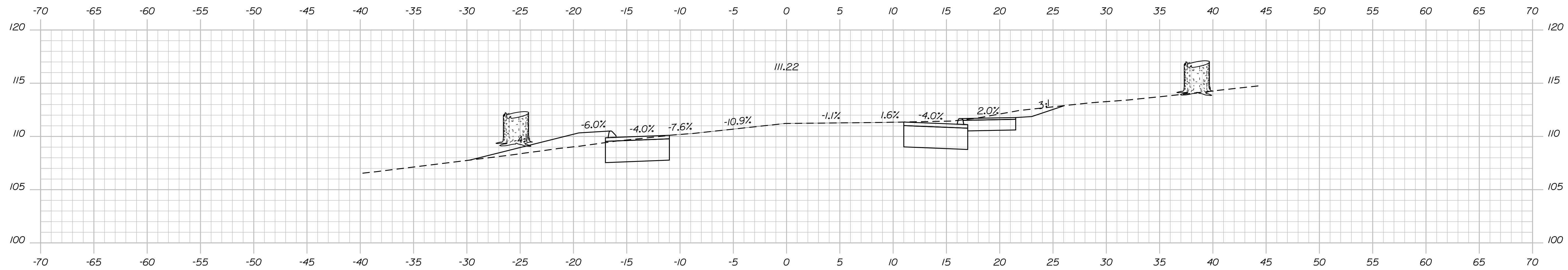

WORKING CROSS SECTIONS -
MODEL HAS NOT BEEN FULLY
DEVELOPED

| | | | |
|--|----------------------------|------------------|-------------|
| STATE OF MAINE DEPARTMENT OF TRANSPORTATION | | HIGHWAY PLANS | |
| ELIOT ROUTE 103 YORK COUNTY | | CROSS SECTIONS | |
| PROJ. MANAGER J. BRUBAKER | BY T. WOLFEL L. MEEK | DATE 06/20/23 | SIGNATURE |
| DESIGN DETAILED | CHECKED/REVIEWED | DESIGN DETAILED | P.E. NUMBER |
| DESIGN DETAILED | DESIGN DETAILED | DESIGN DETAILED | DATE |
| REVISIONS 1 | REVISIONS 2 | REVISIONS 3 | |
| REVISIONS 4 | FIELD CHANGES | | |
| SHEET NUMBER | | | |
| SHEET | | | |
| OF 22 | | | |

Date: 7/21/2023

Username: twolfel

Division: HIGHWAY

Filename: ... \00\HIGHWAY\MSTA\sect.dgn

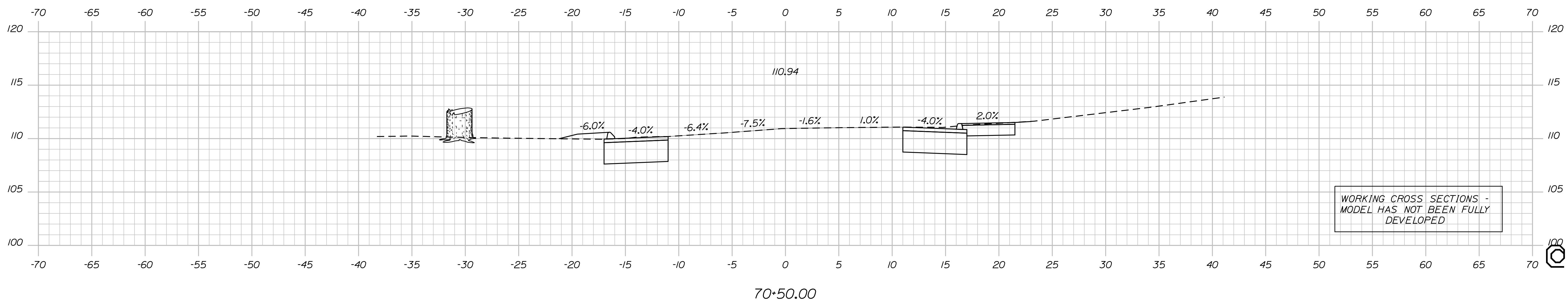
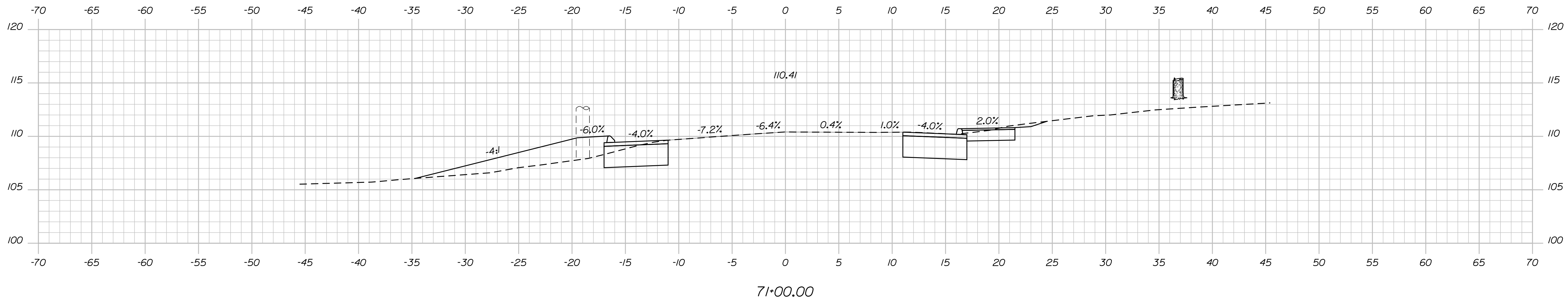
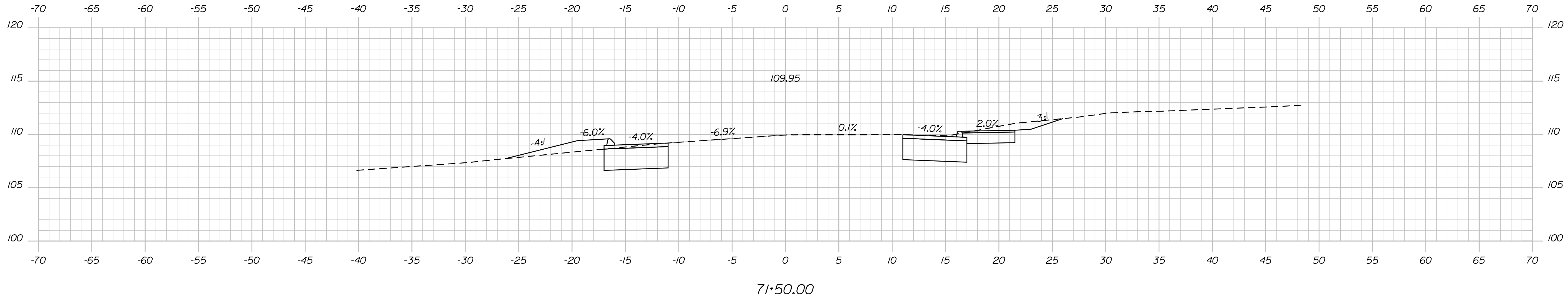

WORKING CROSS SECTIONS -
MODEL HAS NOT BEEN FULLY
DEVELOPED

STATE OF MAINE
DEPARTMENT OF TRANSPORTATION

SIGNATURE

P.E. NUMBER

DATE

DATE

BY

J. BRUBAKER

DESIGN DETAILED

CHECKED/REVIEWED

DESIGN DETAILED

REVISIONS 1

REVISIONS 2

REVISIONS 3

REVISIONS 4

FIELD CHANGES

ELIOT

ROUTE 103

YORK COUNTY

ELIOT

CROSS SECTIONS

SHEET NUMBER

OF 22

OF 22

OF 22

OS SHEET

Date: 7/21/2023

Username: twolfel

Division: HIGHWAY

Filename: ... \00\HIGHWAY\MSTA\sect.dgn

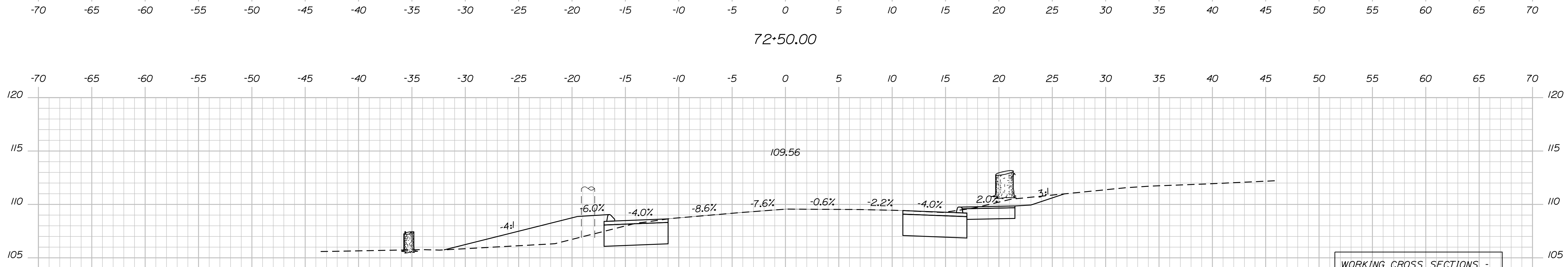
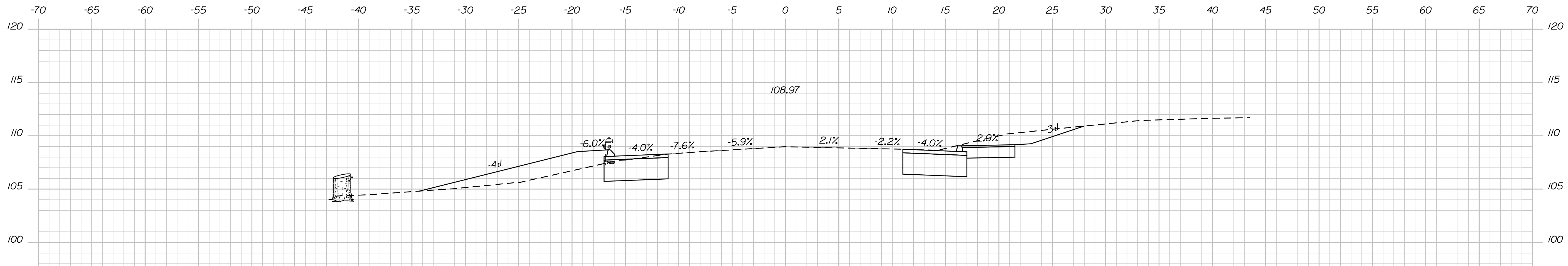
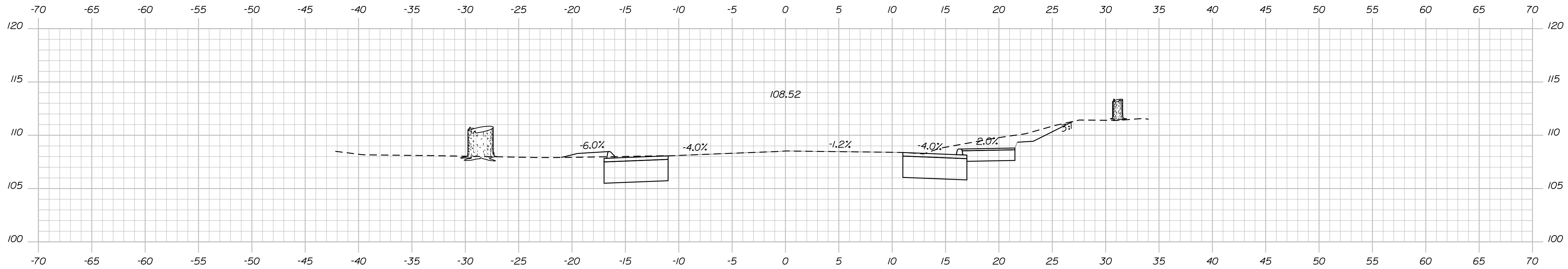

WORKING CROSS SECTIONS -
MODEL HAS NOT BEEN FULLY
DEVELOPED

STATE OF MAINE
DEPARTMENT OF TRANSPORTATION

ELIOT
ROUTE 103 YORK COUNTY

| PROJ. MANAGER | J. BRUBAKER | BY | T. WOLFEL | DATE | 06/2023 |
|-----------------|-------------|---------|-----------|-------------|---------|
| DESIGN DETAILED | T. WOLFEL | CHECKED | L. MEEK | SIGNATURE | |
| DESIGN REVIEWED | L. MEEK | DATE | | P.E. NUMBER | |
| DESIGN DETAILED | | | | DATE | |
| REVISIONS 1 | | | | | |
| REVISIONS 2 | | | | | |
| REVISIONS 3 | | | | | |
| REVISIONS 4 | | | | | |
| FIELD CHANGES | | | | | |

ELIOT
ROUTE 103 YORK COUNTY
CROSS SECTIONS

SHEET NUMBER
10
OF 22

Date: 7/21/2023

Username: twolfel

Division: HIGHWAY

Filename: ... \100\HIGHWAY\MSTA\sect.dgn

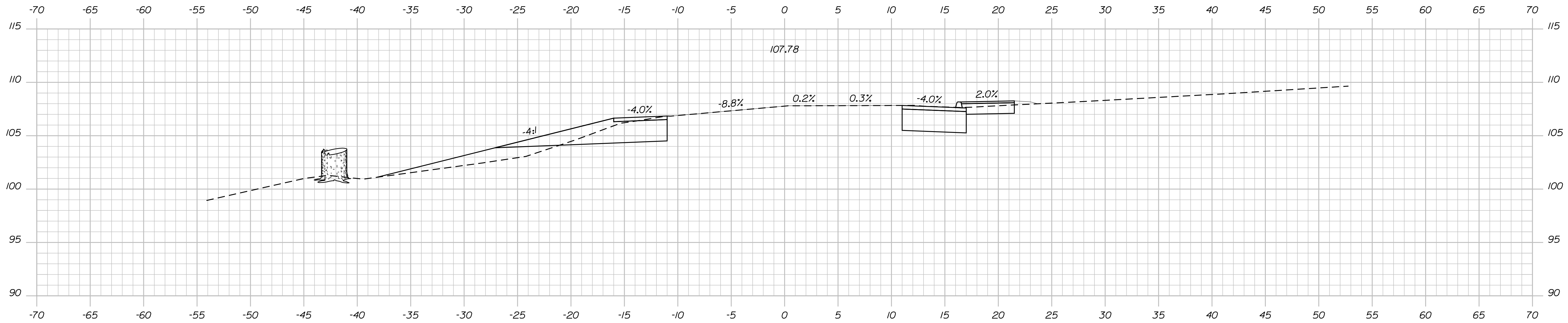

74+50.00

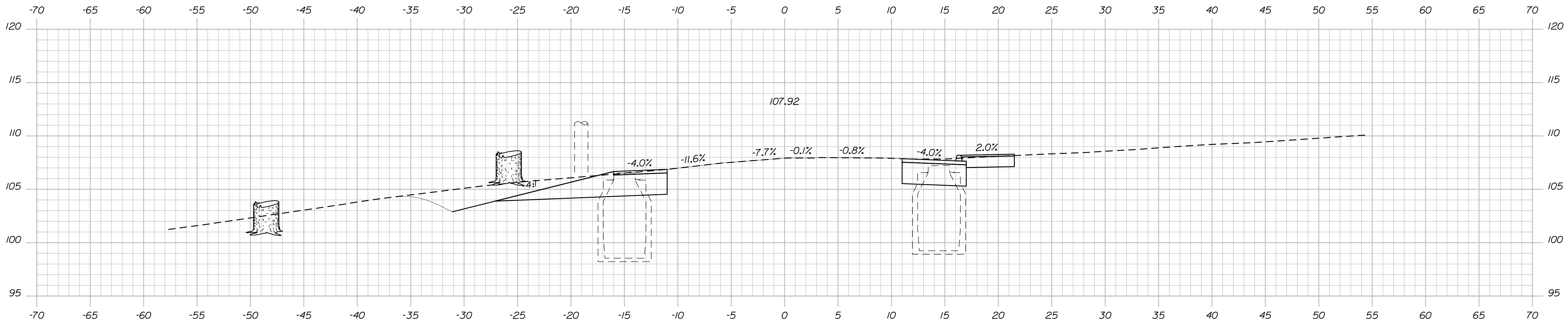

74+00.00

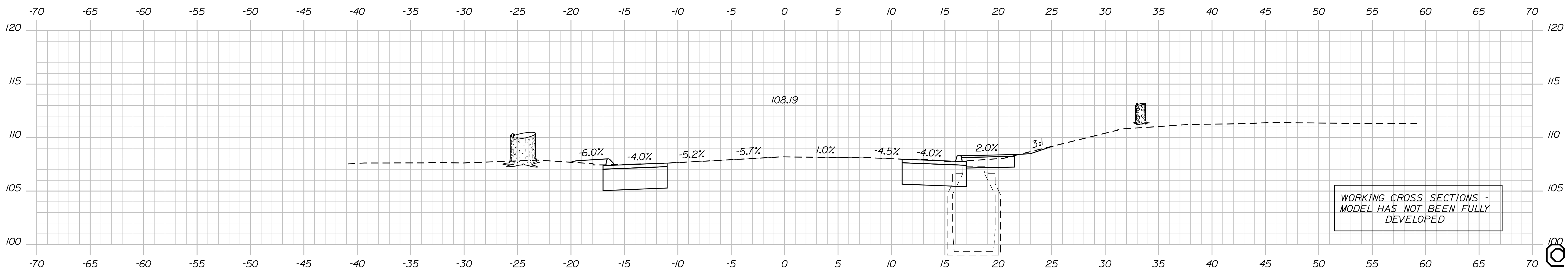

73+50.00

WORKING CROSS SECTIONS -
MODEL HAS NOT BEEN FULLY
DEVELOPED

STATE OF MAINE
DEPARTMENT OF TRANSPORTATION

ELIOT
ROUTE 103 YORK COUNTY

CROSS SECTIONS

SHEET NUMBER

OF 22

HIGHWAY PLANS

| PROJ. MANAGER | BY | DATE |
|------------------|-----------|-------------|
| J. BRUBAKER | T. WOLFEL | 06/20/23 |
| CHECKED-REVIEWED | CHL | SIGNATURE |
| DESIGN-REVIEWED | LEM | P.E. NUMBER |
| DESIGN-DETAILED | | DATE |
| REVISIONS 1 | | |
| REVISIONS 2 | | |
| REVISIONS 3 | | |
| REVISIONS 4 | | |
| FIELD CHANGES | | |

OS SHEET

Date: 7/21/2023

Username: twolfel

Division: HIGHWAY

Filename: ... \00\HIGHWAY\MSTA\sect.dgn

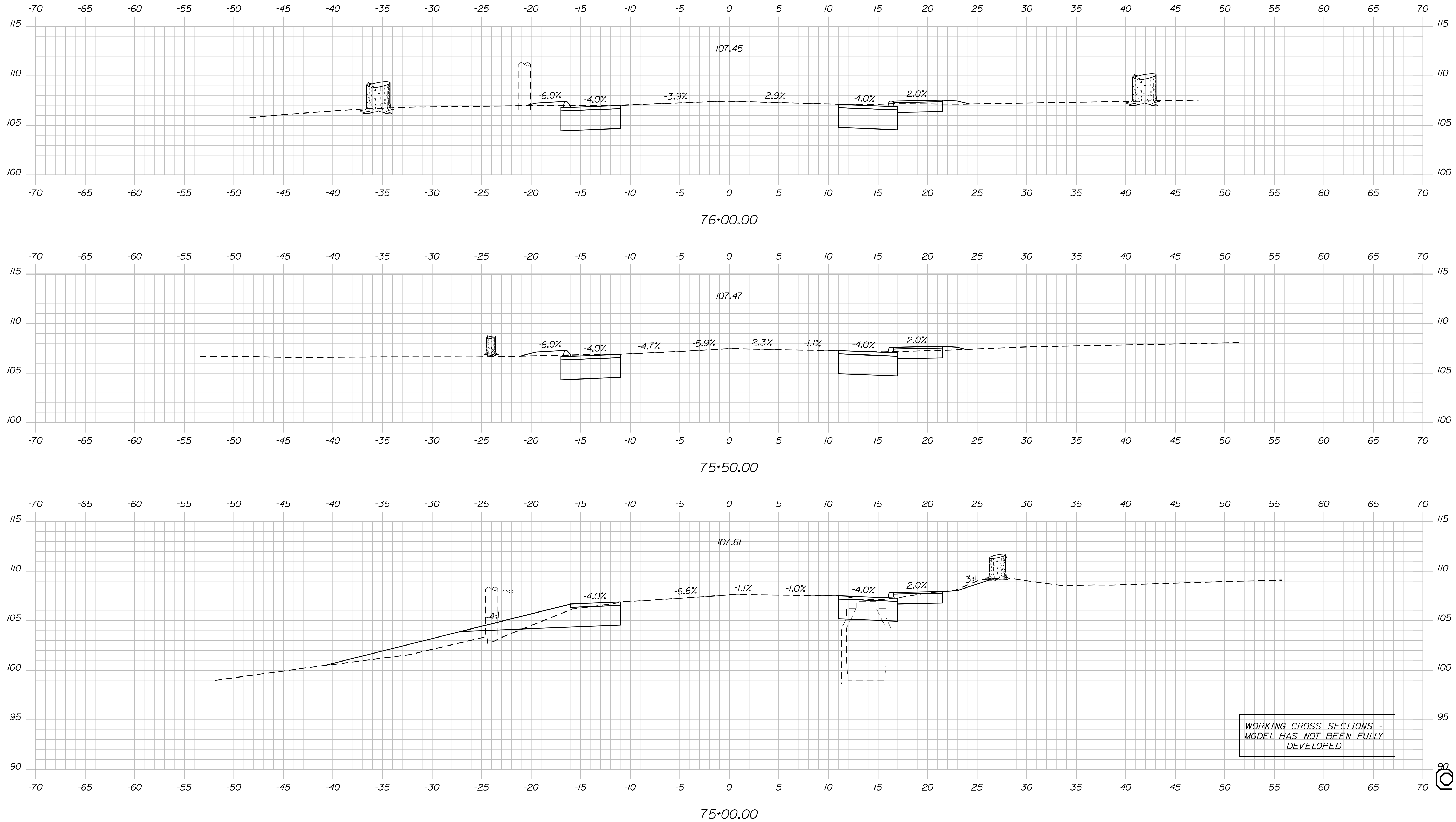

STATE OF MAINE
DEPARTMENT OF TRANSPORTATION

HIGHWAY PLANS

SIGNATURE

DATE

BY
T. WOLFEL
L. MEEK

PROJ. MANAGER
J. BRUBAKER

DESIGN CHECKED
T. WOLFEL
L. MEEK

DESIGN REVIEWED
L. MEEK

DESIGN DETAILED

REVISIONS 1

REVISIONS 2

REVISIONS 3

REVISIONS 4

FIELD CHANGES

P.E. NUMBER

DATE

ELIOT

ROUTE 103

YORK COUNTY

CROSS SECTIONS

SHEET NUMBER

OS SHEET

OF 22

Sta. 75+00.00 to Sta. 76+00.00

Date: 7/21/2023

Username: twolfel

Division: HIGHWAY

Filename: ... \00\HIGHWAY\MSTA\wsect.dgn

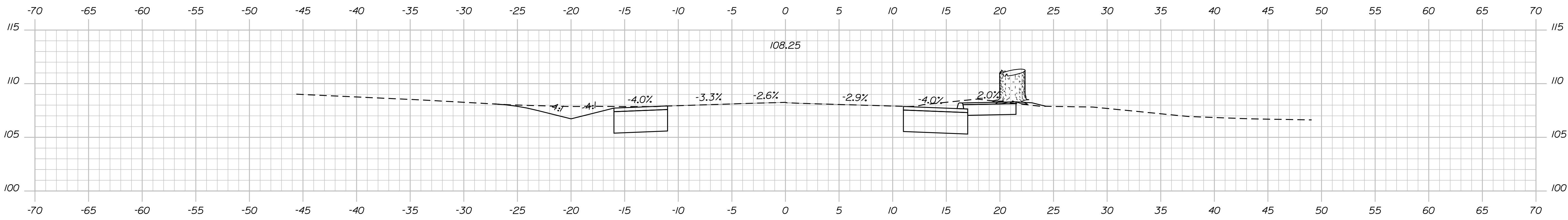

78+00.00

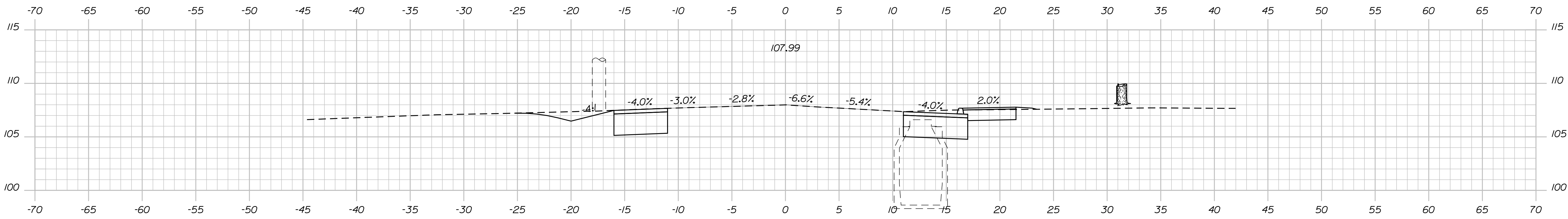

77+50.00

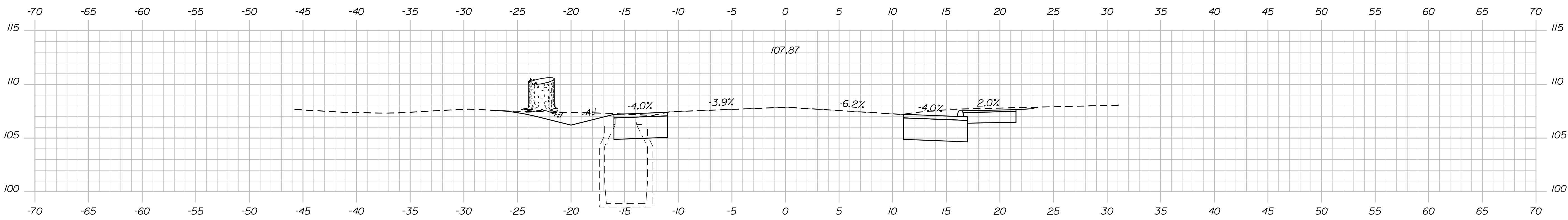

77+00.00

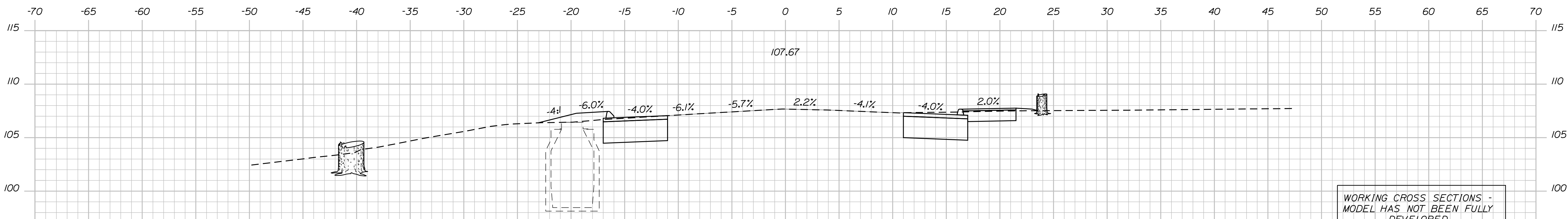

76+50.00

WORKING CROSS SECTIONS -
MODEL HAS NOT BEEN FULLY
DEVELOPED

STATE OF MAINE
DEPARTMENT OF TRANSPORTATION

ELIOT
ROUTE 103 YORK COUNTY

| PROJ. MANAGER | BY | DATE | SIGNATURE | P.E. NUMBER | DATE |
|------------------|-------------------------|---------|-----------|-------------|------|
| J. BRUBAKER | T. WOLFEL CHL LEM | 06/2023 | | | |
| DESIGN DETAILED | | | | | |
| CHECKED-REVIEWED | | | | | |
| DESIGN DETAILED | | | | | |
| REVISIONS 1 | | | | | |
| REVISIONS 2 | | | | | |
| REVISIONS 3 | | | | | |
| REVISIONS 4 | | | | | |
| FIELD CHANGES | | | | | |

CROSS SECTIONS

SHEET NUMBER

10 SHEET

OF 22

Sta. 76+50.00 to Sta. 78+00.00

Date: 7/21/2023

Username: twolfel

Division: HIGHWAY

Filename: ... \100\HIGHWAY\MSTA\sect.dgn

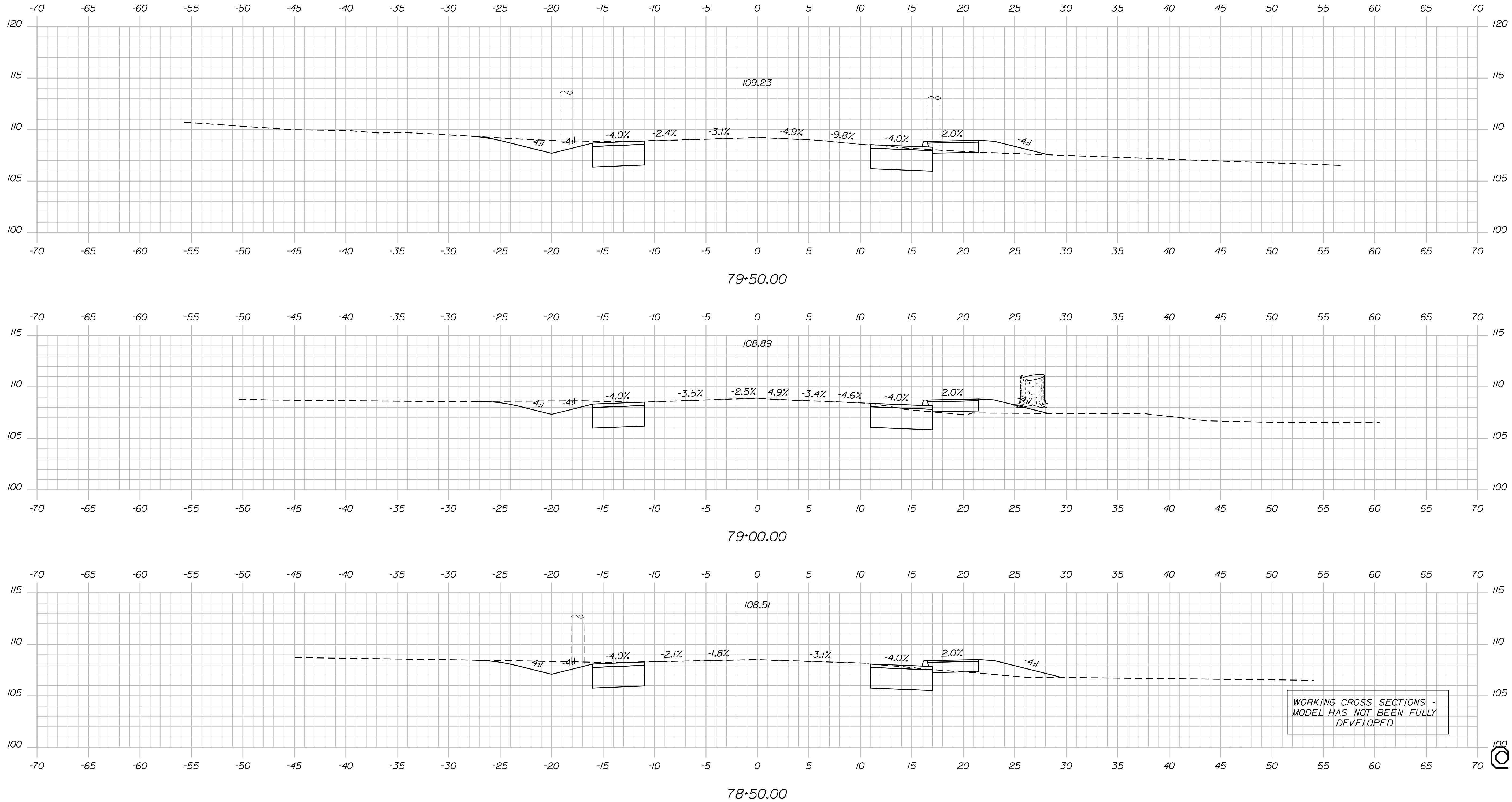

WORKING CROSS SECTIONS -
MODEL HAS NOT BEEN FULLY
DEVELOPED

STATE OF MAINE
DEPARTMENT OF TRANSPORTATION

ELIOT
ROUTE 103 YORK COUNTY

| PROJ. MANAGER | CHECKED | DESIGNED | DATE |
|---------------|-------------|-------------|-------------|
| J. BRUBAKER | T. WOLFEL | L. MEEK | 06/2023 |
| DESIGNED | CHECKED | DESIGNED | DATE |
| REVISIONS 1 | REVISIONS 2 | REVISIONS 3 | REVISIONS 4 |
| FIELD CHANGES | | | |

ELIOT
ROUTE 103 YORK COUNTY
CROSS SECTIONS

SHEET NUMBER
10
OF 22

Date: 7/21/2023

Username: twolfel

Division: HIGHWAY

Filename: ... \00\HIGHWAY\MSTA\sect.dgn

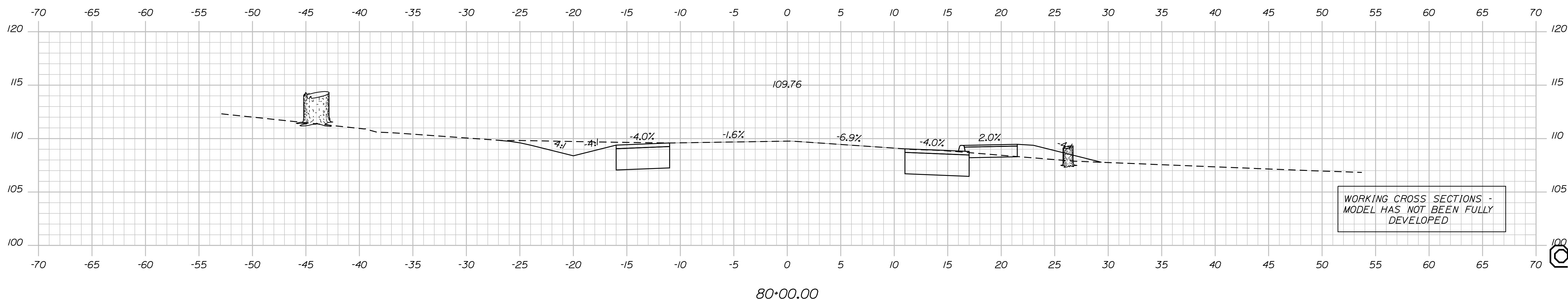
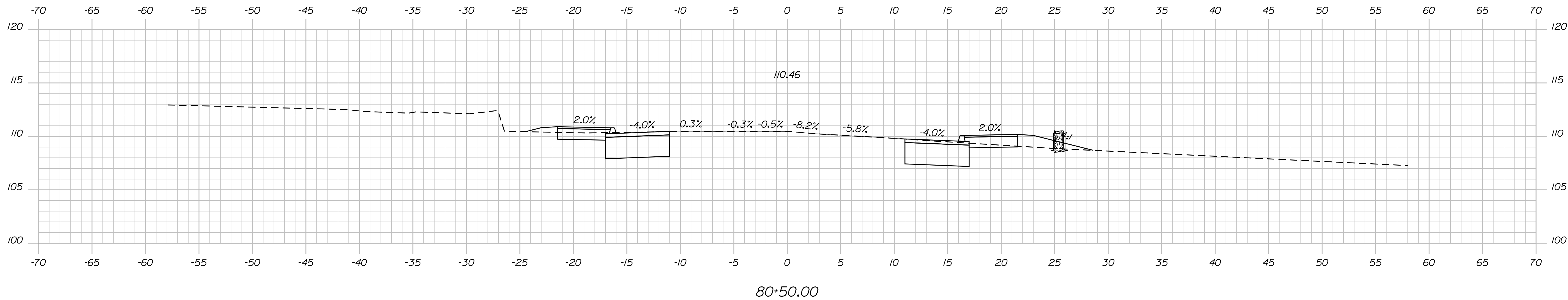
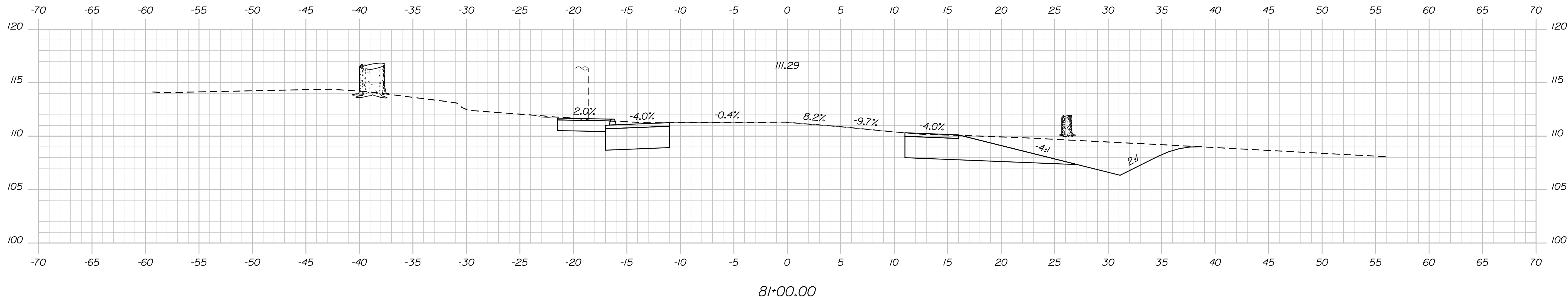

WORKING CROSS SECTIONS -
MODEL HAS NOT BEEN FULLY
DEVELOPED

STATE OF MAINE
DEPARTMENT OF TRANSPORTATION

DESIGN DETAILED
CHECKED/REVIEWED
DESIGNS DETAILED
REVISIONS 1
REVISIONS 2
REVISIONS 3
FIELD CHANGES

| | | | | | |
|------------------|-------------|-----|-----------|-------------|---------|
| PROJ. MANAGER | J. BRUBAKER | BY | T. WOLFEL | DATE | 06/2023 |
| DESIGN DETAILED | T. WOLFEL | CHL | LEM | SIGNATURE | |
| CHECKED/REVIEWED | L. MEEK | LEM | | P.E. NUMBER | |
| DESIGNS DETAILED | | | | DATE | |
| REVISIONS 1 | | | | | |
| REVISIONS 2 | | | | | |
| REVISIONS 3 | | | | | |
| REVISIONS 4 | | | | | |
| FIELD CHANGES | | | | | |

ELIOT ROUTE 103 YORK COUNTY
CROSS SECTIONS

SHEET NUMBER

OF SHEET

OF 22

Sta. 80+00.00 to Sta. 81+00.00

HIGHWAY PLANS

Date: 7/21/2023

Username: twolfel

Division: HIGHWAY

Filename: ... \00\HIGHWAY\MSTA\sect.dgn

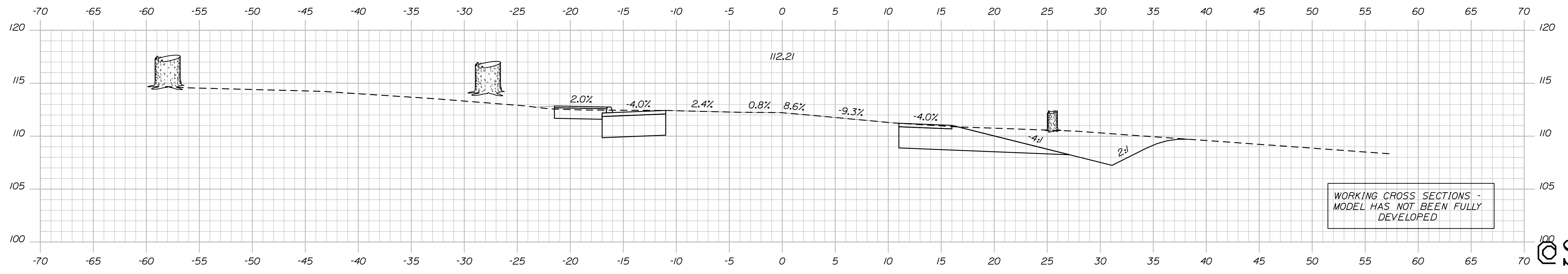
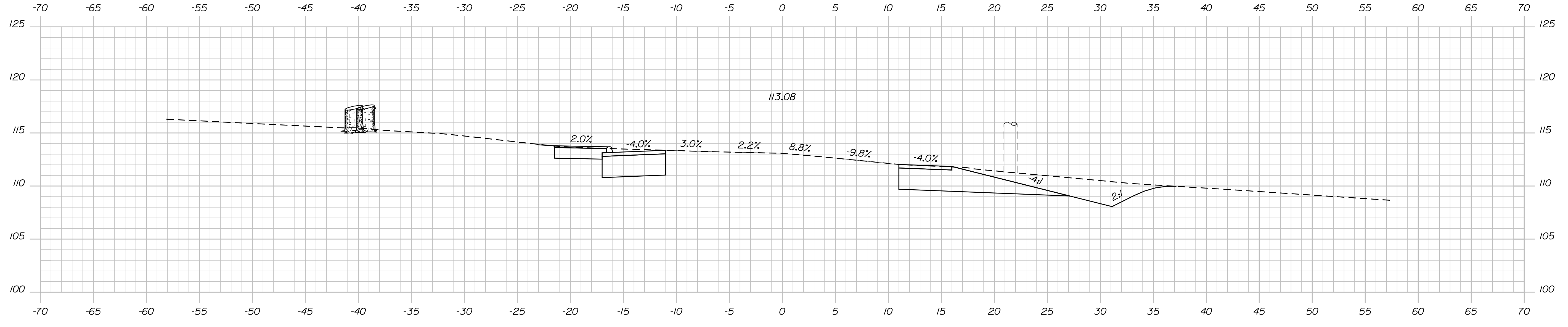
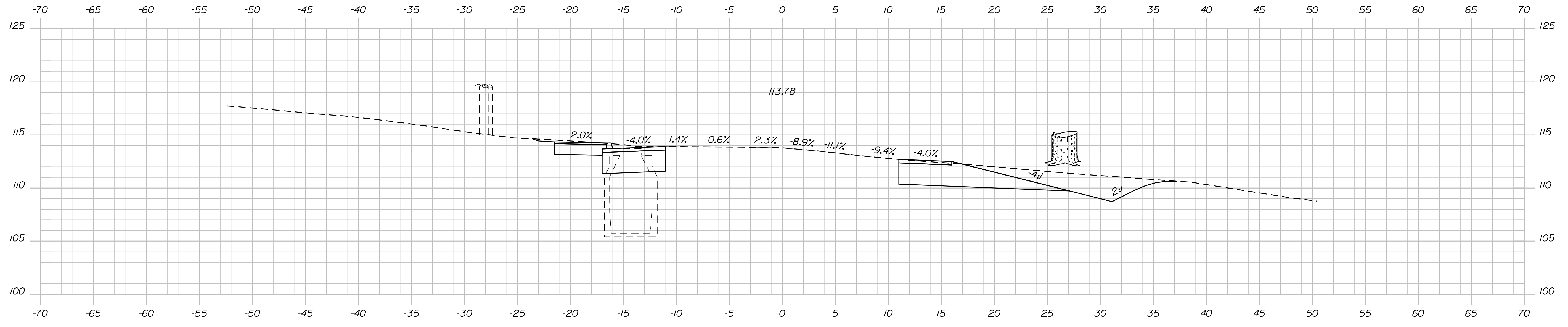

WORKING CROSS SECTIONS -
MODEL HAS NOT BEEN FULLY
DEVELOPED

| | | | |
|--|-------------------------------|------------------------------|-------------|
| STATE OF MAINE DEPARTMENT OF TRANSPORTATION | | HIGHWAY PLANS | |
| PROJ. MANAGER J. BRUBAKER | BY T. WOLFEL | DATE 06/20/23 | SIGNATURE |
| DESIGN DETAILED L. WOLFEL | CHECKED/REVIEWED L. WOLFEL | DESIGN DETAILED L. WOLFEL | P.E. NUMBER |
| DESIGN DETAILED L. WOLFEL | DESIGN DETAILED L. WOLFEL | DESIGN DETAILED L. WOLFEL | DATE |
| REVISIONS 1 | REVISIONS 2 | REVISIONS 3 | REVISIONS 4 |
| ELIOT ROUTE 103 YORK COUNTY | | CROSS SECTIONS | |
| SHEET NUMBER | | OF 22 | |

OS SHEET

Date: 7/21/2023

Username: twolfel

Division: HIGHWAY

Filename: ... \00\HIGHWAY\MSTA\sect.dgn

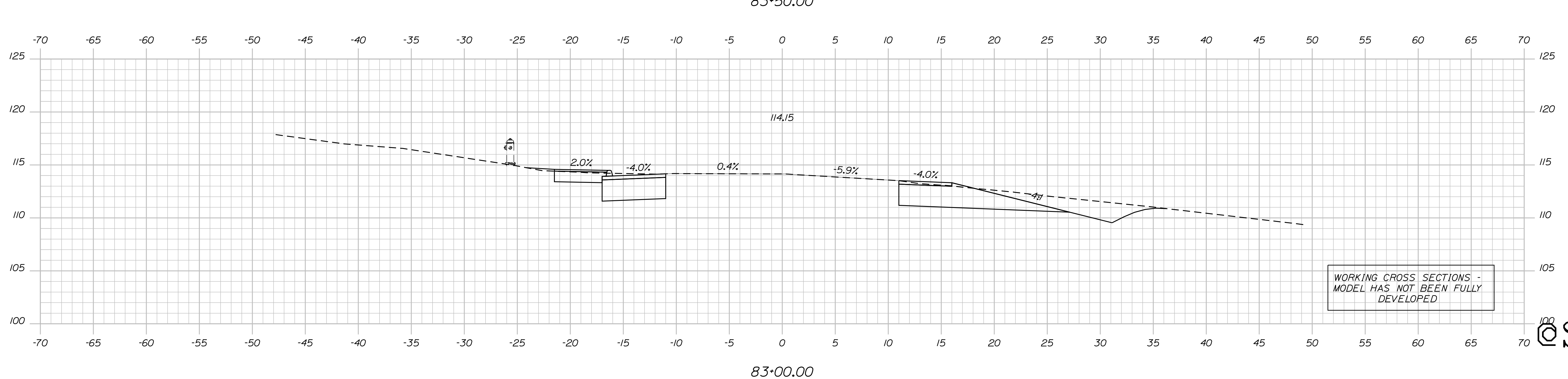
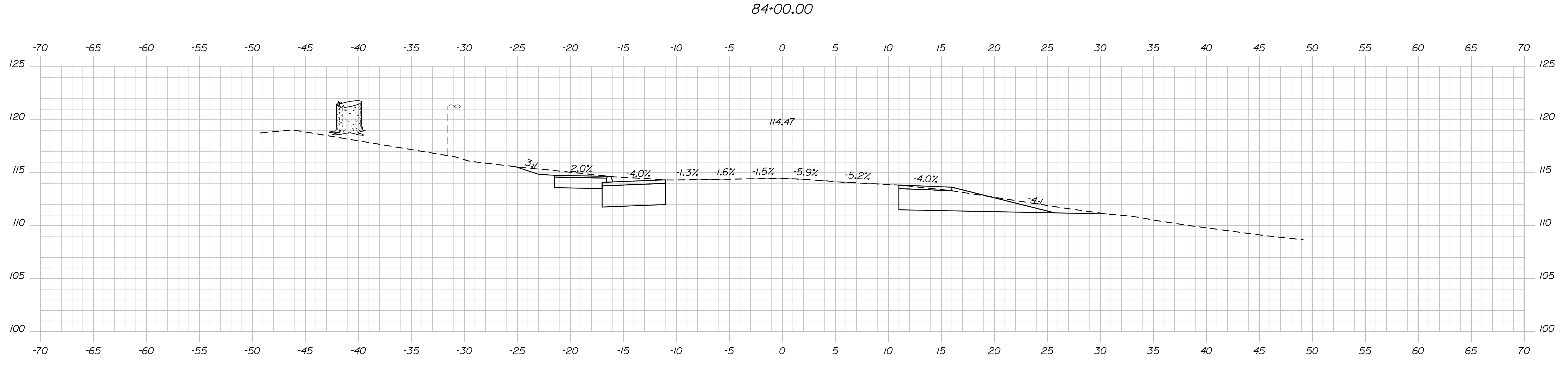
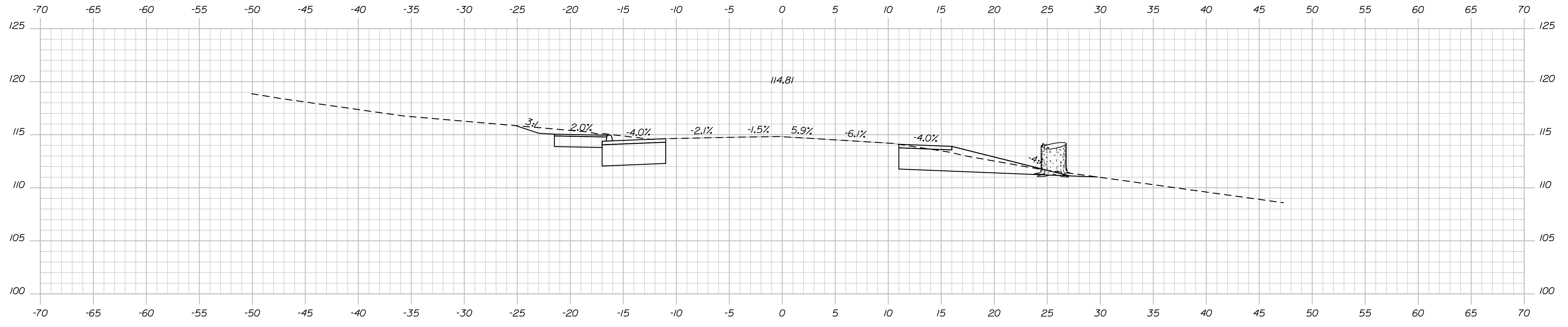

WORKING CROSS SECTIONS -
MODEL HAS NOT BEEN FULLY
DEVELOPED

STATE OF MAINE
DEPARTMENT OF TRANSPORTATION

ELIOT
ROUTE 103 YORK COUNTY

| PROJ. MANAGER | J. BRUBAKER | BY | DATE |
|------------------|-------------|-----|---------|
| CHECKED-REVIEWED | T. WOLFEL | CHL | 06/2023 |
| DESIGN-REVIEWED | L. WEEK | LEM | |
| DESIGN-REVIEWED | | | |
| REVISIONS 1 | | | |
| REVISIONS 2 | | | |
| REVISIONS 3 | | | |
| REVISIONS 4 | | | |
| FIELD CHANGES | | | |

CROSS SECTIONS

SHEET NUMBER

OF SHEET

OF 22

Sta. 83+00.00 to Sta. 84+00.00

Date: 7/21/2023

Username: twolfel

Division: HIGHWAY

Filename: ... \00\HIGHWAY\MSTA\wsect.dgn

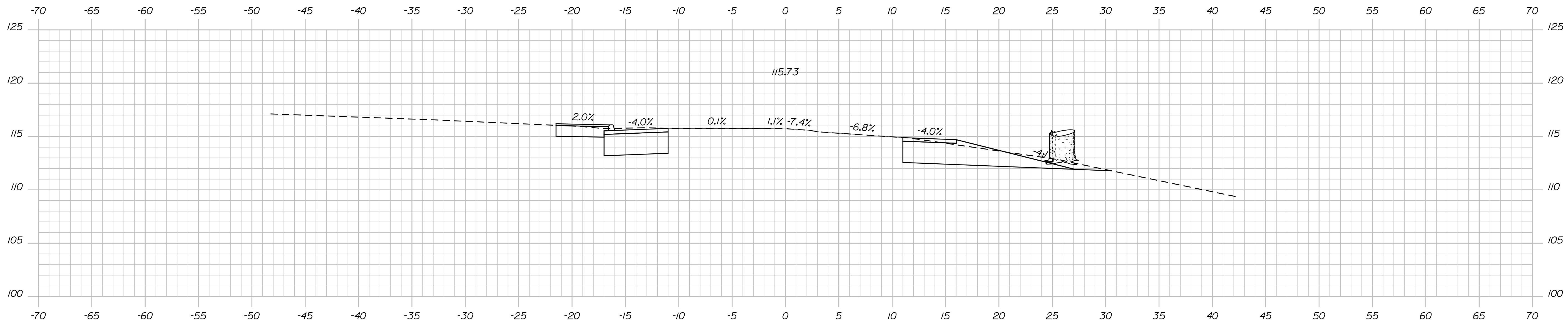

85+73.00

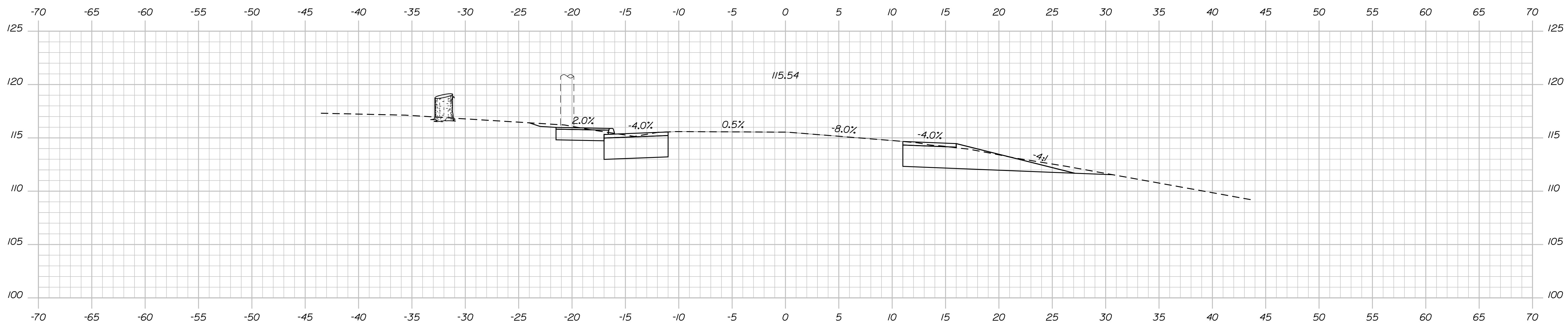

85+00.00

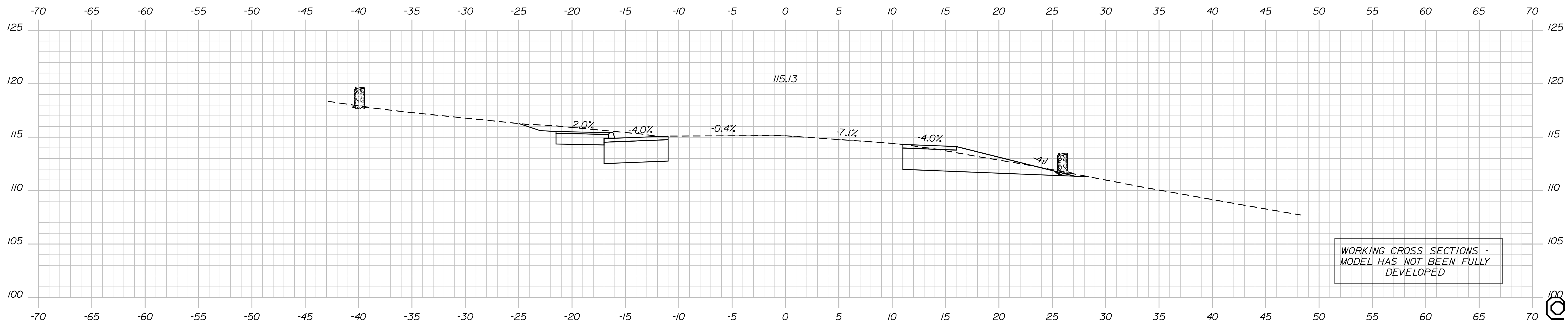

84+50.00

WORKING CROSS SECTIONS -
MODEL HAS NOT BEEN FULLY
DEVELOPED

STATE OF MAINE
DEPARTMENT OF TRANSPORTATION

ELIOT ROUTE 103 YORK COUNTY

| PROJ. MANAGER | BY | DATE | SIGNATURE | P.E. NUMBER | DATE |
|------------------|-----------|---------|-----------|-------------|------|
| J. BRUBAKER | T. WOLFEL | 06/2023 | | | |
| DESIGN DETAILED | CHL | | | | |
| CHECKED/REVIEWED | LEM | | | | |
| DESIGN DETAILED | | | | | |
| REVISIONS 1 | | | | | |
| REVISIONS 2 | | | | | |
| REVISIONS 3 | | | | | |
| REVISIONS 4 | | | | | |
| FIELD CHANGES | | | | | |

CROSS SECTIONS

SHEET NUMBER

OF SHEET

OF 22

Sta. 84+50.00 to Sta. 85+50.00

Date: 7/21/2023

Username: twolfel

Division: HIGHWAY

Filename: ... \00\HIGHWAY\MSTA\wsect.dgn

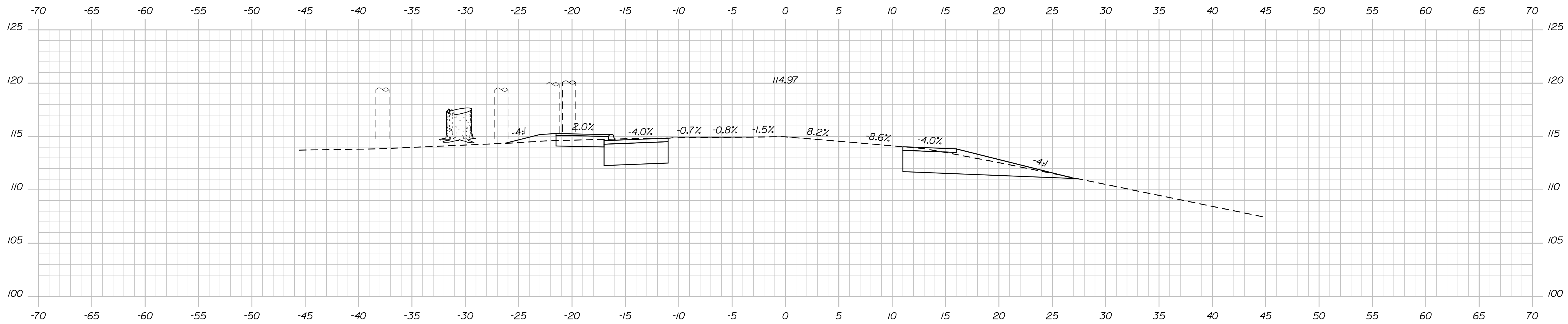

87+00.00

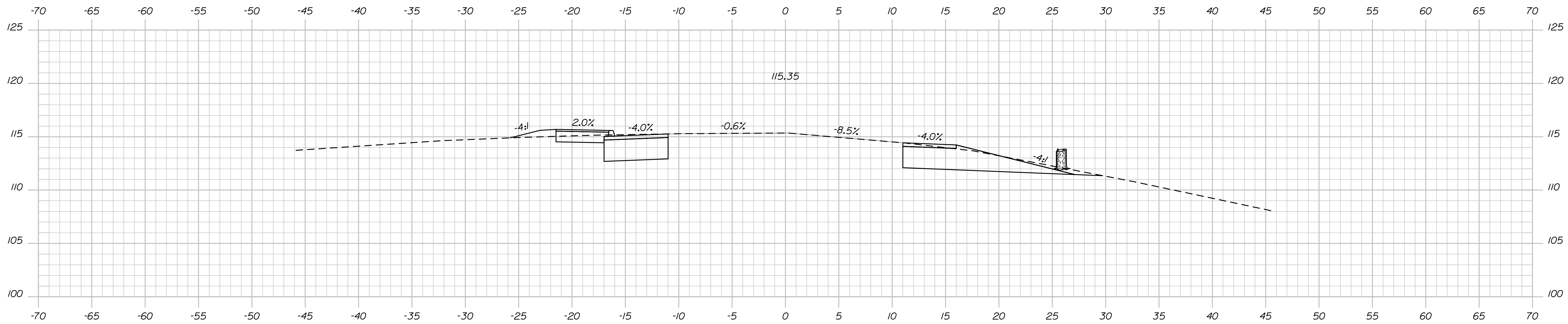

86+50.00

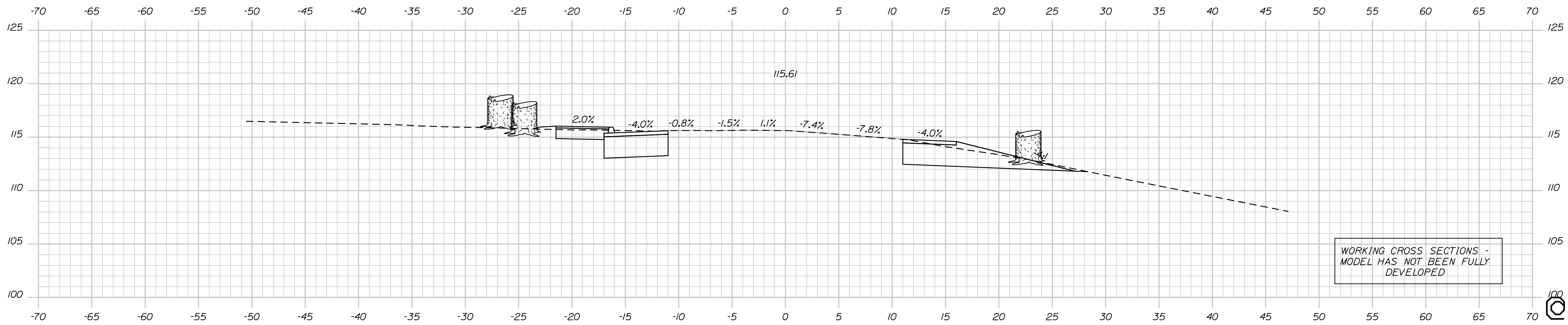

86+00.00

WORKING CROSS SECTIONS -
MODEL HAS NOT BEEN FULLY
DEVELOPED

STATE OF MAINE
DEPARTMENT OF TRANSPORTATION

DATE
06/2023

SIGNATURE

BY
T. WOLFEL

PROJ. MANAGER
J. BRUBAKER

CHECKED-REVIEWED
L. WEEK

DESIGN-DETAILED
L. WEEK

DESIGN-DETAILED
L. WEEK

DESIGN-DETAILED
L. WEEK

REVISIONS 1

REVISIONS 2

REVISIONS 3

REVISIONS 4

FIELD CHANGES

P.E. NUMBER

DATE

ELIOT
ROUTE 103 YORK COUNTY

CROSS SECTIONS

SHEET NUMBER

OS SHEET

OF 22

Sta. 86+00.00 to Sta. 87+00.00

Date: 7/21/2023

Username: twolfel

Division: HIGHWAY

Filename: ... \00\HIGHWAY\MSTA\sect.dgn

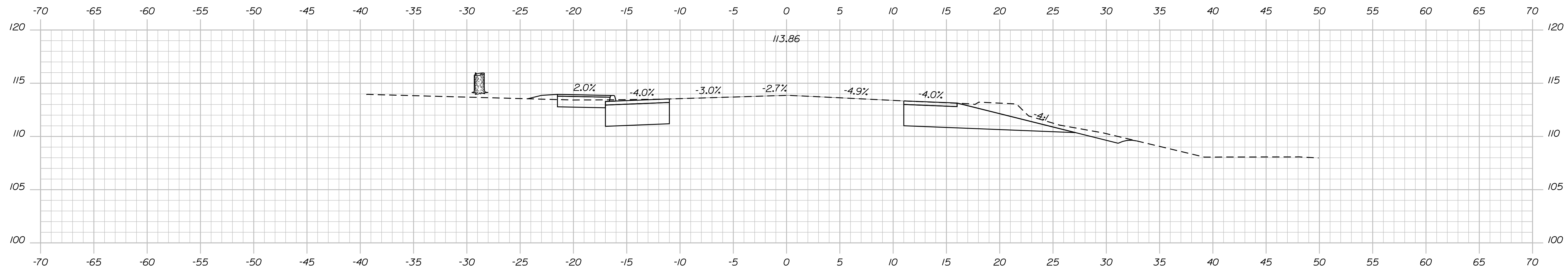

88+50.00

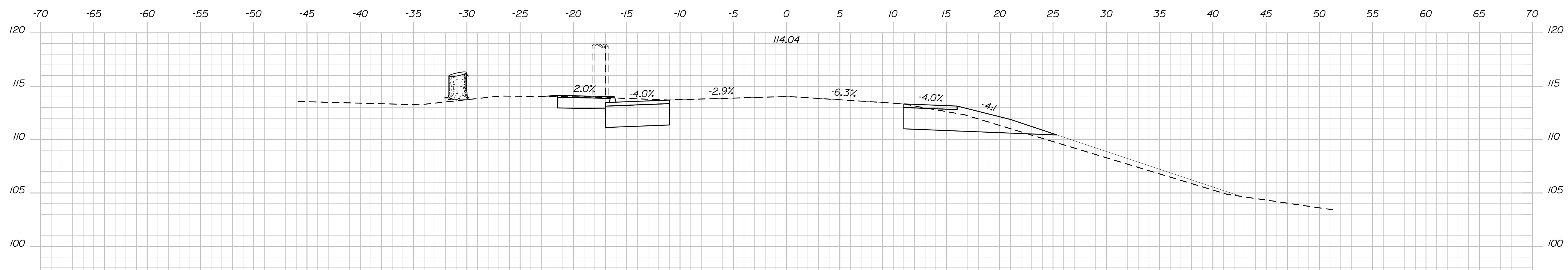

88+00.00

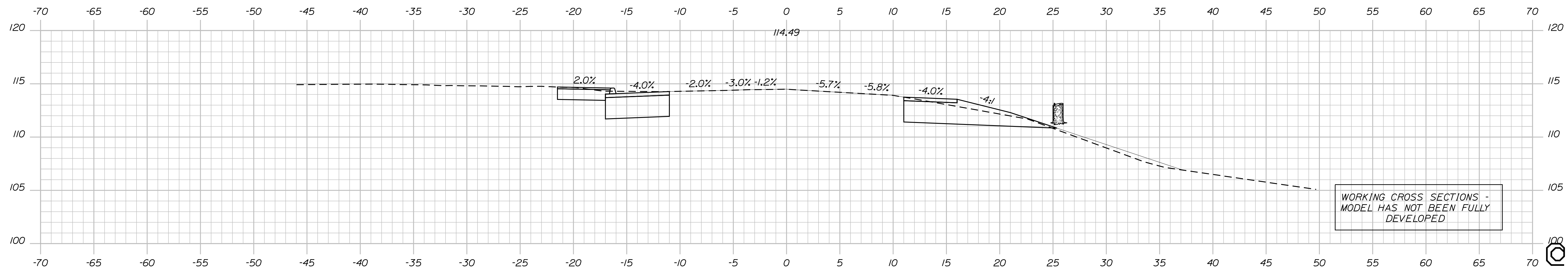

87+50.00

STATE OF MAINE
DEPARTMENT OF TRANSPORTATION

HIGHWAY PLANS

PROJ. MANAGER
DESIGN DETAILED
CHECKED/REVIEWED
DESIGN DETAILED
REVISIONS 1
REVISIONS 2
REVISIONS 3
REVISIONS 4
FIELD CHANGES

DATE
06/20/23

BY
J. BRUBAKER
T. WOLFEL
L. MEEK

CHIL
LEM

SIGNATURE
P.E. NUMBER
DATE

ELIOT
ROUTE 103 YORK COUNTY

CROSS SECTIONS

SHEET NUMBER

OF SHEET

OF 22

Sta. 87+50.00 to Sta. 88+50.00

Date: 7/21/2023

Username: twolfel

Division: HIGHWAY

Filename: ... \00\HIGHWAY\MSTA\sect.dgn

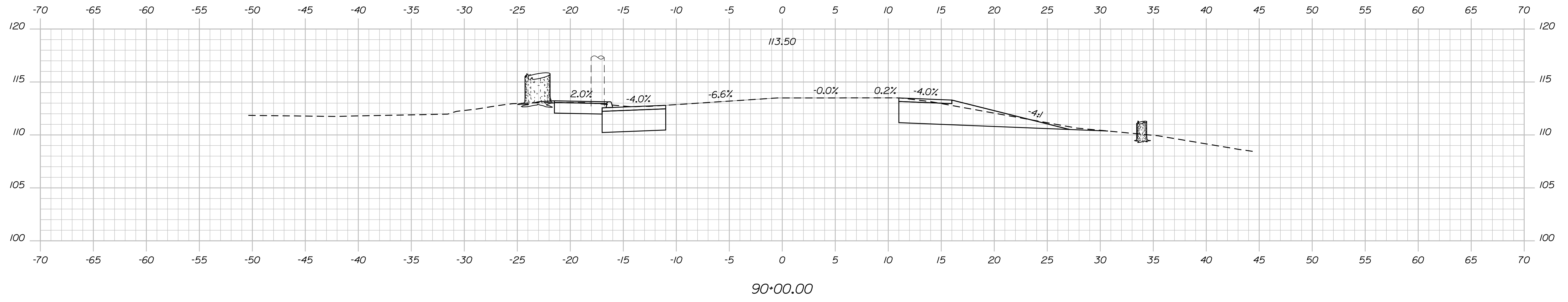

90+00.00

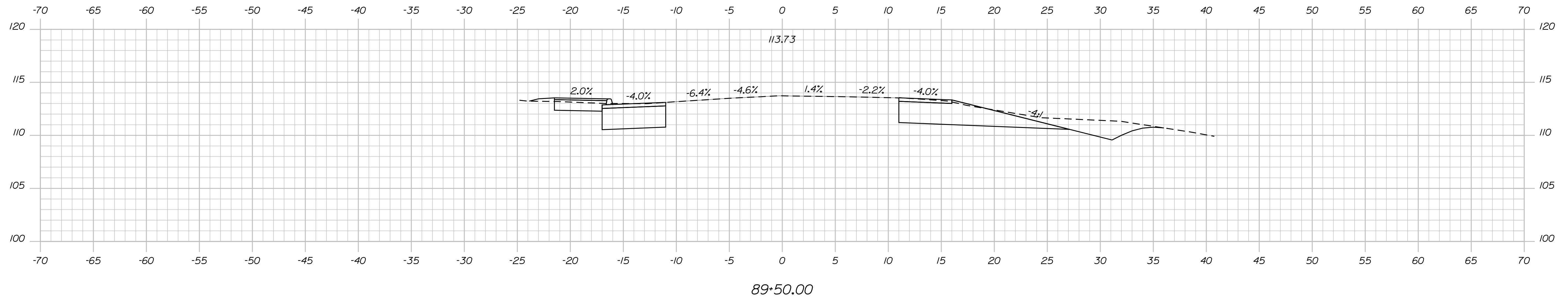

89+50.00

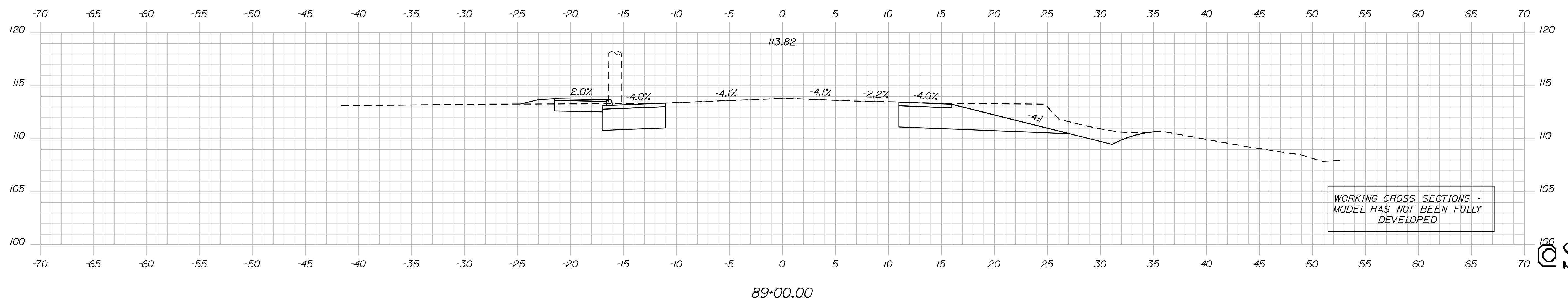

89+00.00

WORKING CROSS SECTIONS -
MODEL HAS NOT BEEN FULLY
DEVELOPED

STATE OF MAINE
DEPARTMENT OF TRANSPORTATION

SIGNATURE
P.E. NUMBER
DATE

| PROJ. MANAGER | BY | DATE |
|------------------|-----------|---------|
| J. BRUBAKER | T. WOLFEL | 06/2023 |
| CHECKED-REVIEWED | CHL | |
| DESIGN-REVIEWED | LEM | |
| DESIGN-REVIEWED | L. MEEK | |
| DESIGN-REVIEWED | | |
| REVISIONS 1 | | |
| REVISIONS 2 | | |
| REVISIONS 3 | | |
| REVISIONS 4 | | |
| FIELD CHANGES | | |

ELIOT ROUTE 103 YORK COUNTY
CROSS SECTIONS

SHEET NUMBER

OF SHEET

OF 22

Sta. 89+00.00 to Sta. 90+00.00

Date: 7/21/2023

Username: twolfel

Division: HIGHWAY

Filename: ... \100\HIGHWAY\MSTA\vssect.dgn

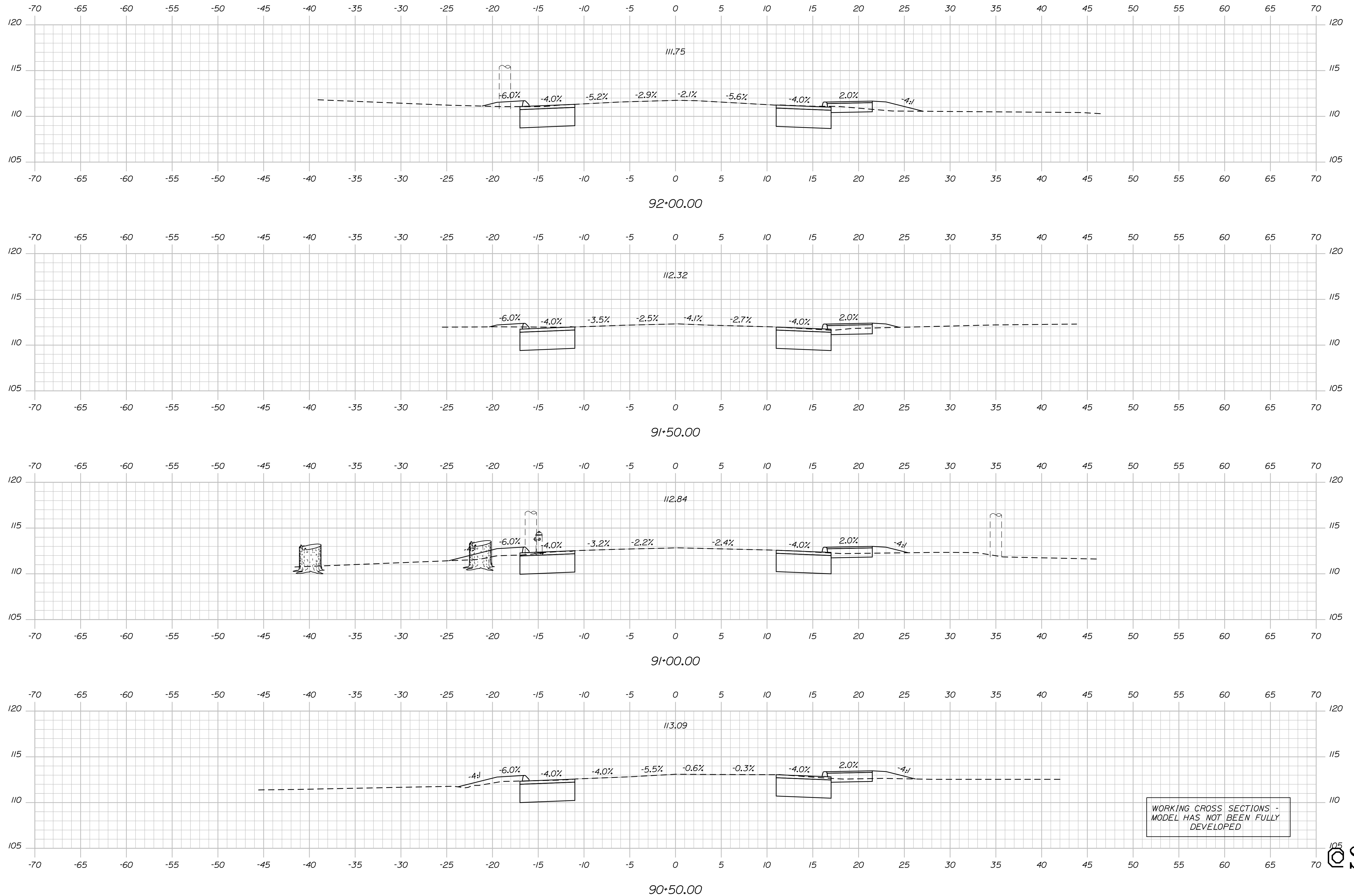

WORKING CROSS SECTIONS -
 MODEL HAS NOT BEEN FULLY
 DEVELOPED

STATE OF MAINE
 DEPARTMENT OF TRANSPORTATION
 HIGHWAY PLANS

ELIOT ROUTE 103 YORK COUNTY

| PROJ. MANAGER | BY | DATE |
|------------------|-----|----------|
| J. BRUBAKER | CHL | 06/20/23 |
| DESIGN-DETAILED | LEM | |
| CHECKED-REVIEWED | | |
| DESIGN-DETAILED | | |
| REVISIONS 1 | | |
| REVISIONS 2 | | |
| REVISIONS 3 | | |
| REVISIONS 4 | | |
| FIELD CHANGES | | |

CROSS SECTIONS

SHEET NUMBER

OF SHEET

Date: 7/21/2023

Username: twolfel

Division: HIGHWAY

Filename: ... \100\HIGHWAY\MSTA\wsect.dgn

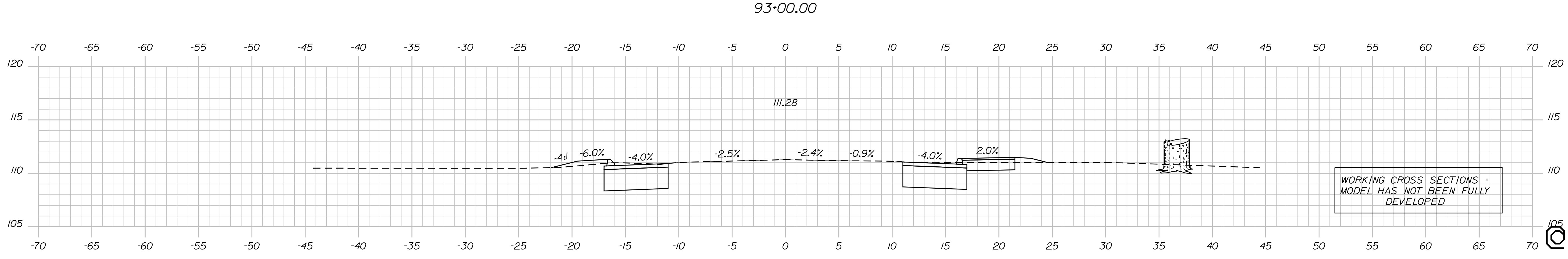
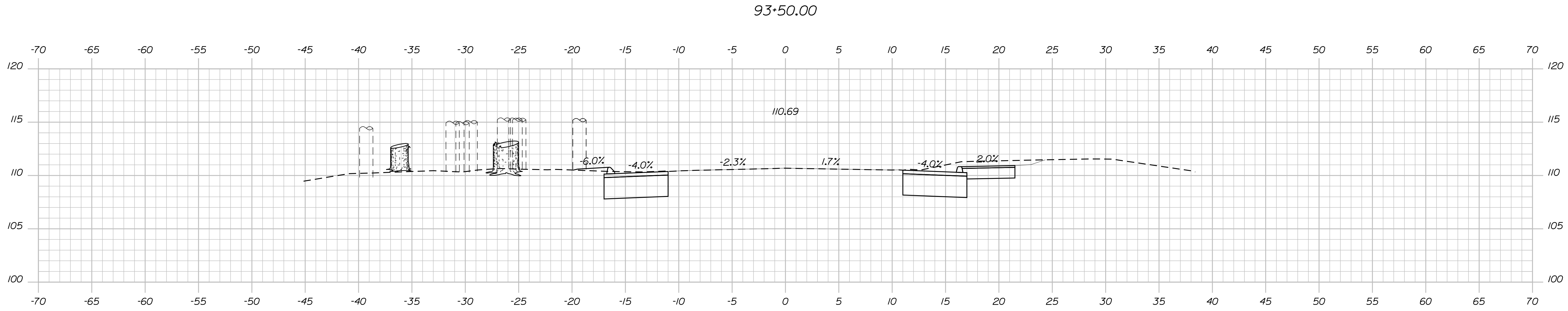
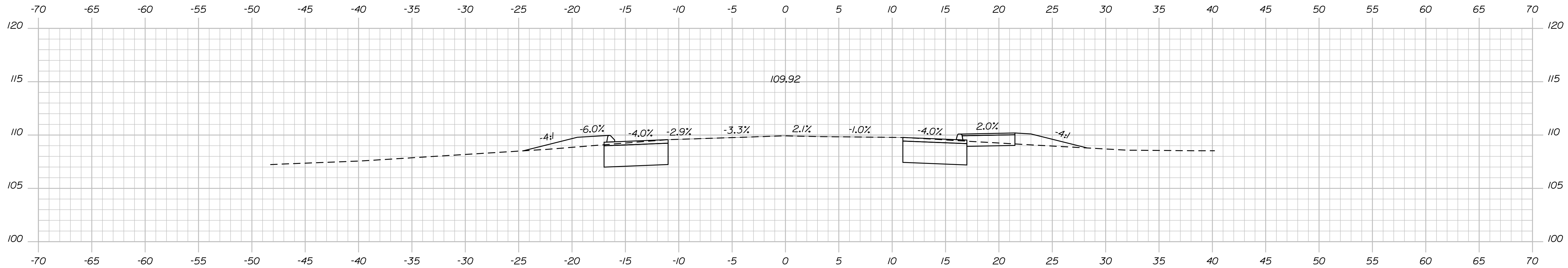

WORKING CROSS SECTIONS -
MODEL HAS NOT BEEN FULLY
DEVELOPED

STATE OF MAINE
DEPARTMENT OF TRANSPORTATION

ELIOT
ROUTE 103 YORK COUNTY

| PROJ. MANAGER | BY | DATE |
|------------------|-----------|-------------|
| J. BRUBAKER | T. WOLFEL | 06/2023 |
| DESIGN DETAILED | CHL | SIGNATURE |
| CHECKED-REVIEWED | LEM | P.E. NUMBER |
| DESIGN DETAILED | | DATE |
| REVISIONS 1 | | |
| REVISIONS 2 | | |
| REVISIONS 3 | | |
| REVISIONS 4 | | |
| FIELD CHANGES | | |

ELIOT
ROUTE 103 YORK COUNTY
CROSS SECTIONS

SHEET NUMBER

OF SHEET

OF 22

Sta. 92+50.00 to Sta. 93+50.00

Date: 7/21/2023

Username: twolfel

Division: HIGHWAY

Filename: ...100\HIGHWAY\MSTA\wsect.dgn

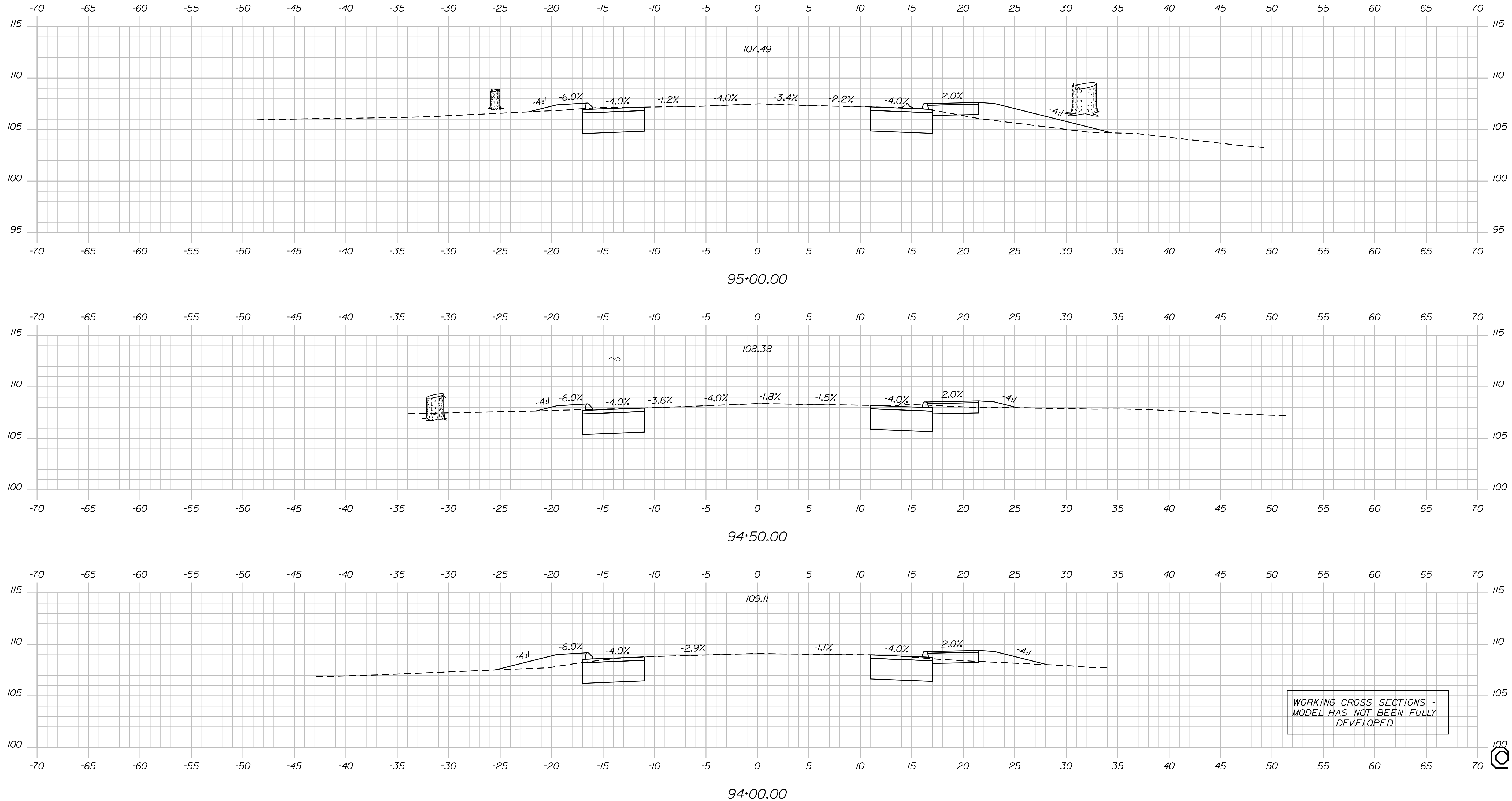

STATE OF MAINE
DEPARTMENT OF TRANSPORTATION

HIGHWAY PLANS

SIGNATURE

DATE

BY

CHIL

LEM

DATE

DESIGN DETAILED

CHECKED/REVIEWED

DESIGN DETAILED

DESIGN DETAILED

REVISIONS 1

REVISIONS 2

REVISIONS 3

REVISIONS 4

FIELD CHANGES

P.E. NUMBER

DATE

SHEET NUMBER

OF 22

ELIOT ROUTE 103 YORK COUNTY CROSS SECTIONS

WORKING CROSS SECTIONS -
MODEL HAS NOT BEEN FULLY
DEVELOPED

OS SHEET

Date: 7/21/2023

Username: twolfel

Division: HIGHWAY

Filename: ...100\HIGHWAY\MSTA\sect.dgn

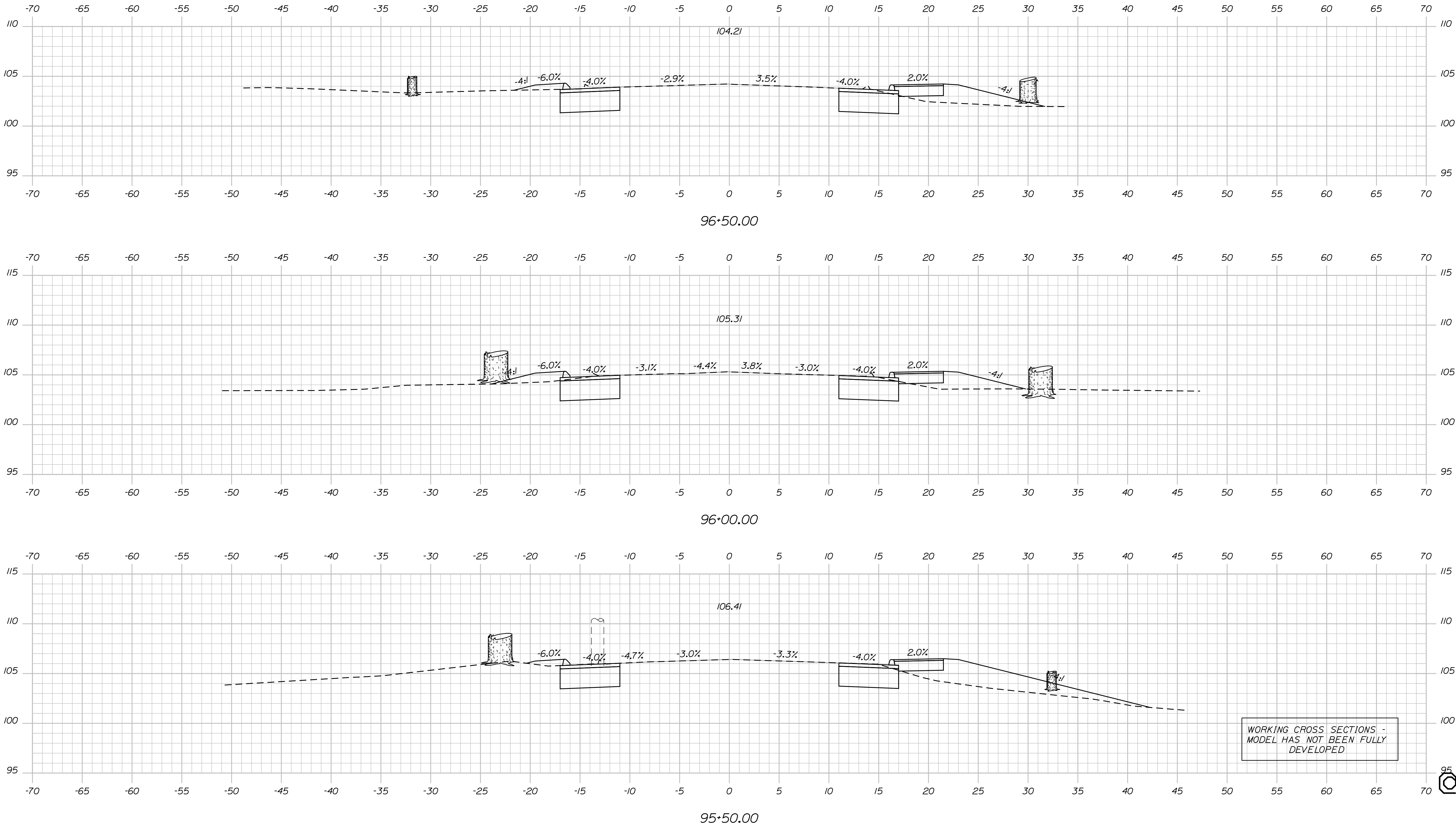

WORKING CROSS SECTIONS -
MODEL HAS NOT BEEN FULLY
DEVELOPED

STATE OF MAINE
DEPARTMENT OF TRANSPORTATION

ELIOT
ROUTE 103 YORK COUNTY

CROSS SECTIONS

SHEET NUMBER

OF 22

DESIGN DETAILED
CHECKED-REVIEWED
DESIGN DETAILED
REVISIONS 1
REVISIONS 2
REVISIONS 3
REVISIONS 4
FIELD CHANGES

PROJ. MANAGER
J. BRUBAKER
BY
T. WOLFEL
L. MEEK
DATE
06/2023

DESIGN DETAILED
CHECKED-REVIEWED
DESIGN DETAILED
REVISIONS 1
REVISIONS 2
REVISIONS 3
REVISIONS 4
FIELD CHANGES

SIGNATURE
P.E. NUMBER
DATE

HIGHWAY PLANS

OS SHEET

Date: 7/21/2023

Username: twolfel

Division: HIGHWAY

Filename: ... \00\HIGHWAY\MSTA\sect.dgn

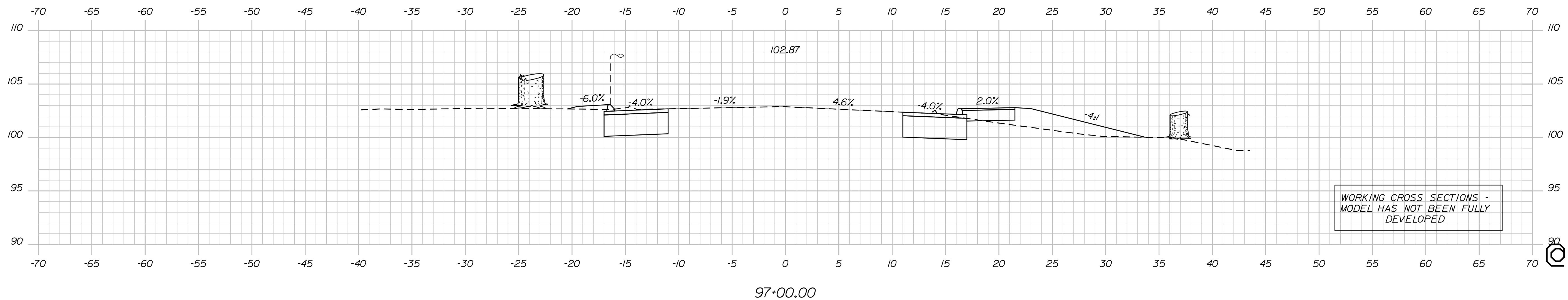
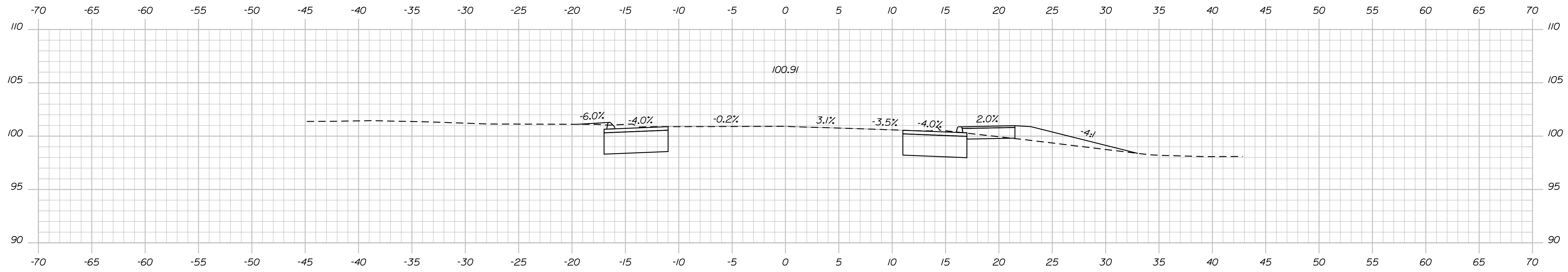
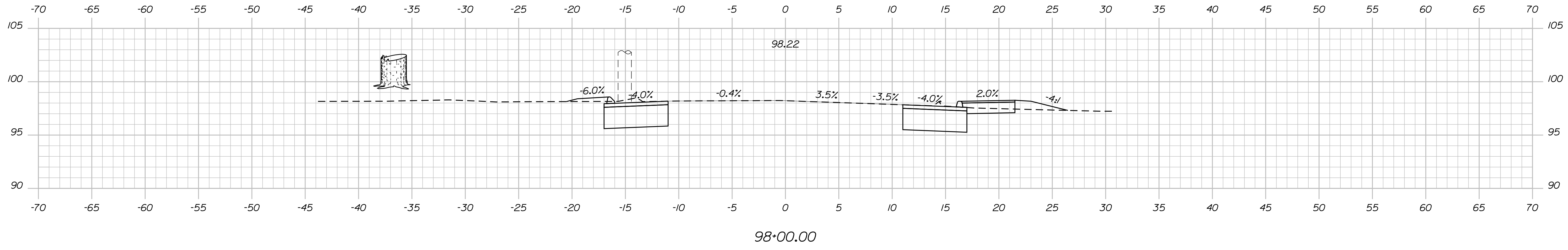

WORKING CROSS SECTIONS -
MODEL HAS NOT BEEN FULLY
DEVELOPED

STATE OF MAINE
DEPARTMENT OF TRANSPORTATION

ELIOT ROUTE 103 YORK COUNTY

| PROJ. MANAGER | BY | DATE |
|------------------|-----------|-------------|
| J. BRUBAKER | T. WOLFEL | 06/2023 |
| CHECKED-REVIEWED | CHL | SIGNATURE |
| DESIGN-REVIEWED | LEM | P.E. NUMBER |
| DESIGN-REVIEWED | | DATE |
| REVISIONS 1 | | |
| REVISIONS 2 | | |
| REVISIONS 3 | | |
| REVISIONS 4 | | |
| FIELD CHANGES | | |

ELIOT ROUTE 103 YORK COUNTY
CROSS SECTIONS

SHEET NUMBER
10
OF 22

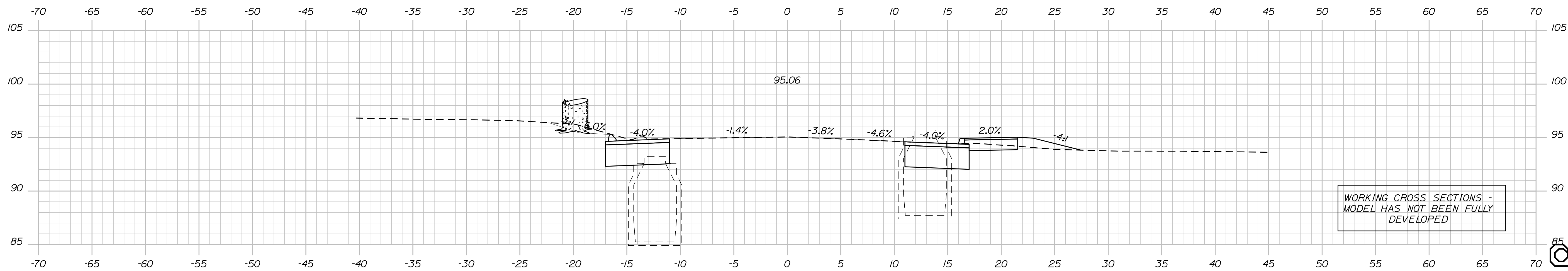
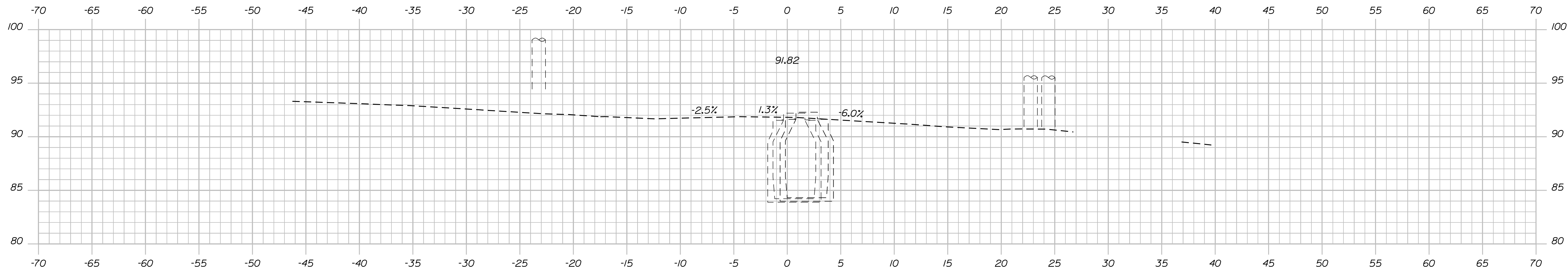

STATE OF MAINE
DEPARTMENT OF TRANSPORTATION

ELIOT
ROUTE 103 YORK COUNTY

CROSS SECTIONS

PROJ. MANAGER: J. BRUBAKER
DESIGN: T. WOLFE
CHECKED: L. MEEK
DESIGNED: L. MEEK
REVISIONS: 1, 2, 3, 4
FIELD CHANGES

SHEET NUMBER

OF SHEET

OF 22

HIGHWAY PLANS

DATE: 06/20/23
SIGNATURE:
P.E. NUMBER:
DATE:

Date: 7/21/2023

Username: twolfel

Division: HIGHWAY

Filename: ... \100\HIGHWAY\MSTA\sect.dgn

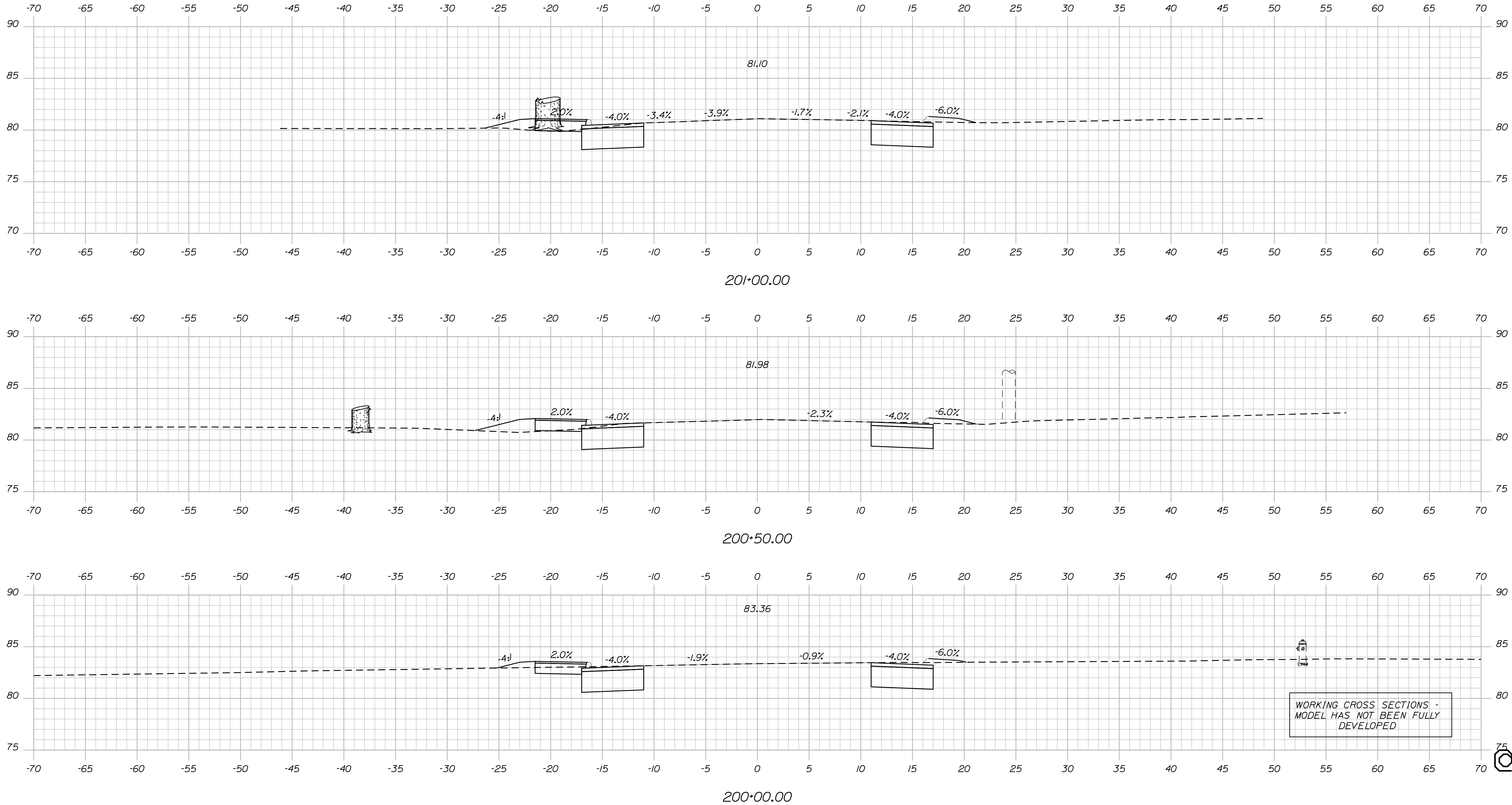

STATE OF MAINE
DEPARTMENT OF TRANSPORTATION

SIGNATURE

DATE

BY

CHIL
LEM

J. BRUBAKER
T. WOLFEL
L. MEEK

DESIGN DETAILED
CHECKED-REVIEWED
DESIGN DETAILED

REVISIONS 1
REVISIONS 2
REVISIONS 3
REVISIONS 4

FIELD CHANGES

ELIOT ROUTE 10 YORK COUNTY

CROSS SECTIONS

SHEET NUMBER

OF 22

HIGHWAY PLANS

OS SHEET

Date: 7/21/2023

Username: twolfel

Division: HIGHWAY

Filename: ...100\HIGHWAY\MSTA\sect.dgn

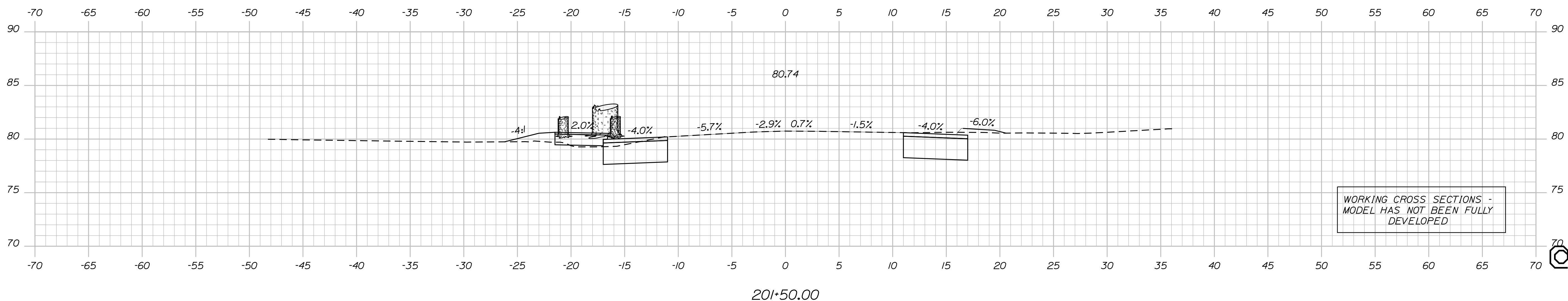
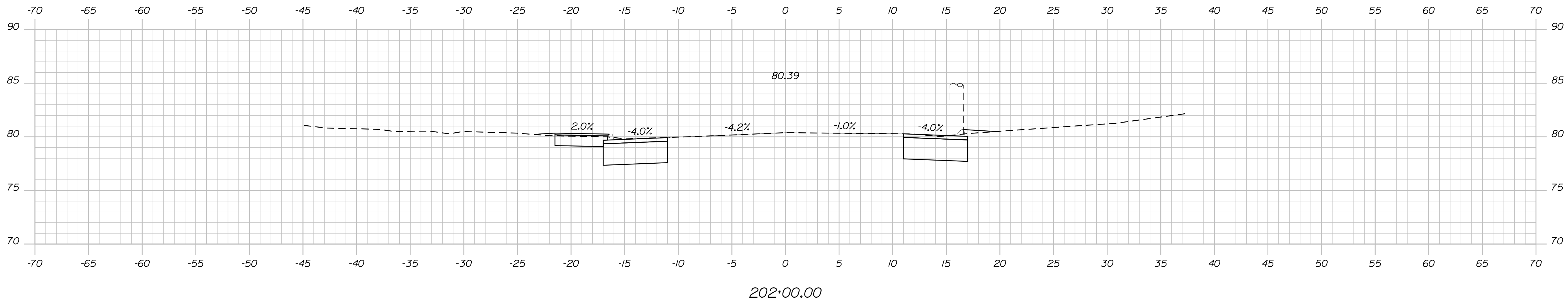
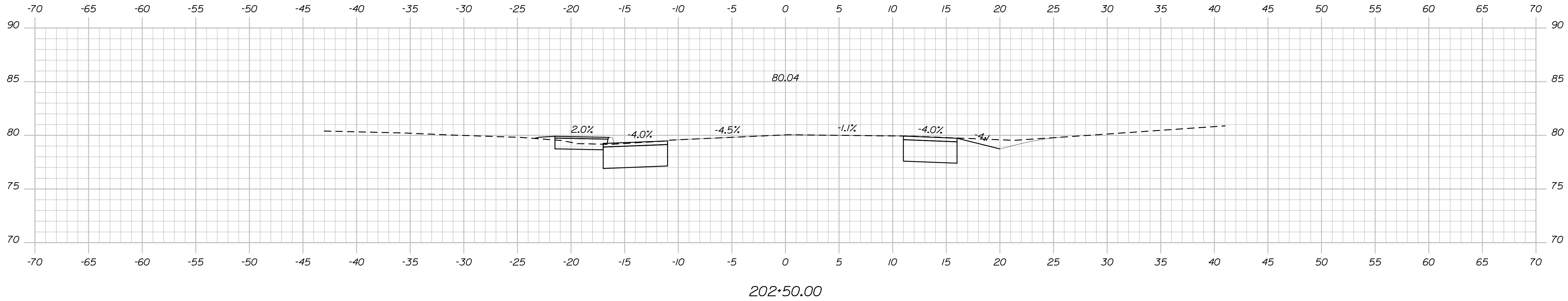

WORKING CROSS SECTIONS -
MODEL HAS NOT BEEN FULLY
DEVELOPED

STATE OF MAINE
DEPARTMENT OF TRANSPORTATION

ELIOT
ROUTE 103 YORK COUNTY

CROSS SECTIONS

SHEET NUMBER

OF 22

HIGHWAY PLANS

DATE
06/2023

BY
J. BRUBAKER
T. WOLFEL
L. MEEK

DESIGN DETAILED
CHECKED-REVIEWED
DESIGN DETAILED
REVISIONS 1
REVISIONS 2
REVISIONS 3
REVISIONS 4
FIELD CHANGES

SIGNATURE
P.E. NUMBER
DATE

OS SHEET

Date: 7/21/2023

Username: twolfel

Division: HIGHWAY

Filename: ... \100\HIGHWAY\MSTA\vssect.dgn

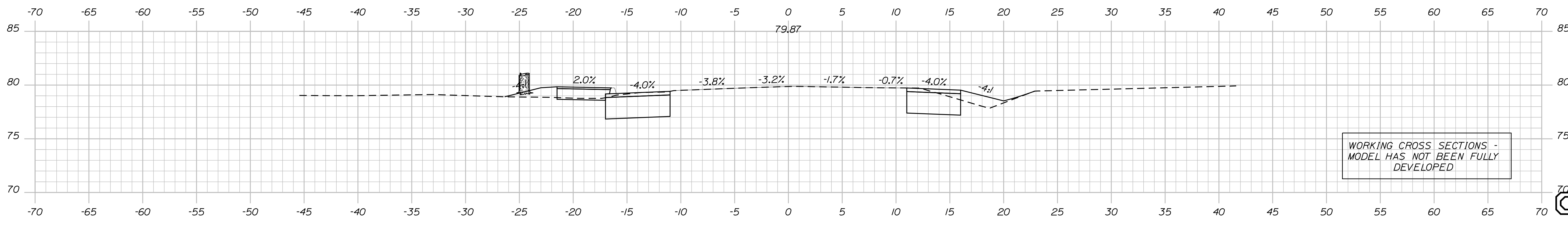
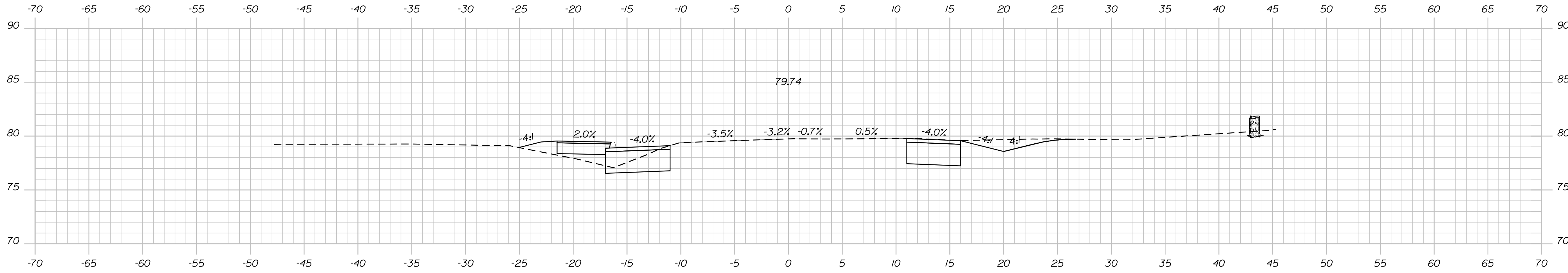
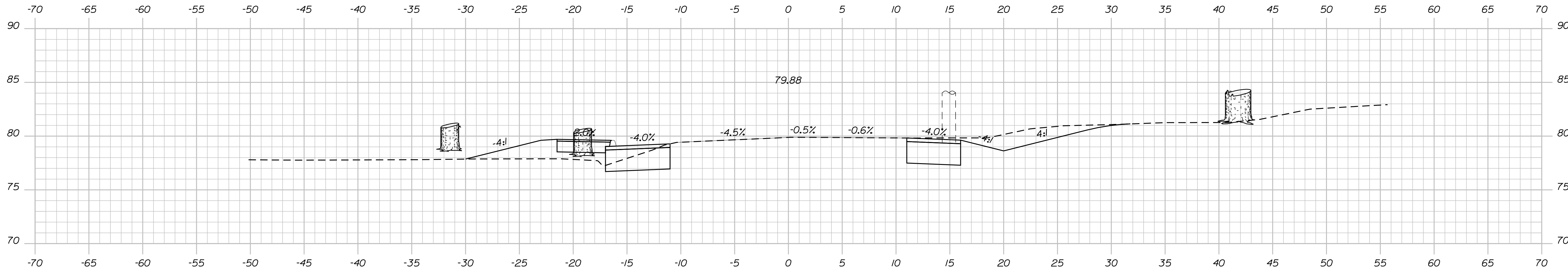

WORKING CROSS SECTIONS -
MODEL HAS NOT BEEN FULLY
DEVELOPED

STATE OF MAINE
DEPARTMENT OF TRANSPORTATION

ELIOT
ROUTE 103 YORK COUNTY

| PROJ. MANAGER | BY | DATE |
|------------------|------------------|-------------|
| J. BRUBAKER | T. WOLFEL CHL | 06/2023 |
| CHECKED-REVIEWED | L. MEEK LEM | SIGNATURE |
| DESIGNS DETAILED | | P.E. NUMBER |
| REVISIONS 1 | | DATE |
| REVISIONS 2 | | |
| REVISIONS 3 | | |
| REVISIONS 4 | | |
| FIELD CHANGES | | |

ELIOT
ROUTE 103 YORK COUNTY
CROSS SECTIONS

SHEET NUMBER

OS SHEET

OF 22

Date: 7/21/2023

Username: twolfel

Division: HIGHWAY

Filename: ... \00\HIGHWAY\MSTA\sect.dgn

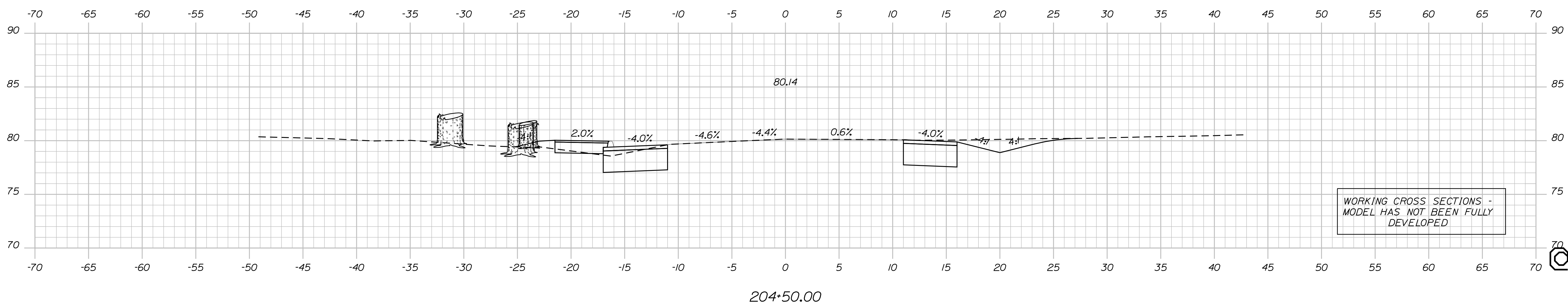
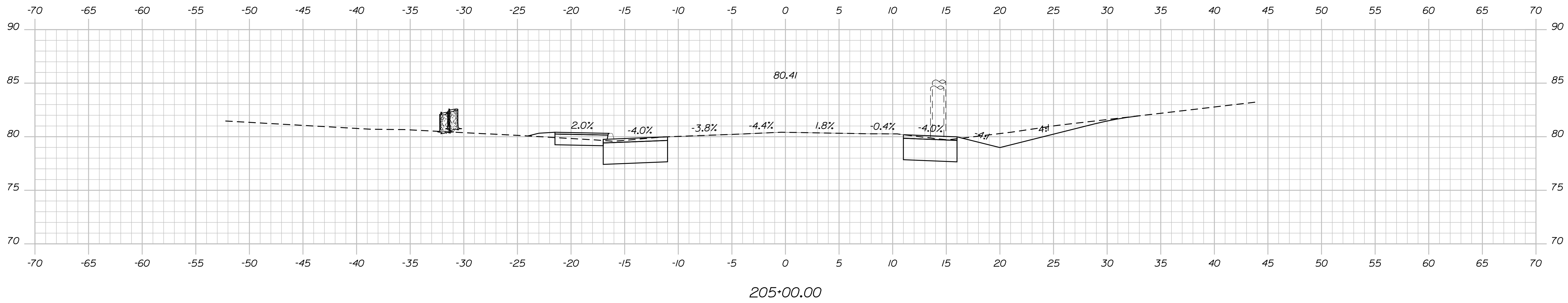
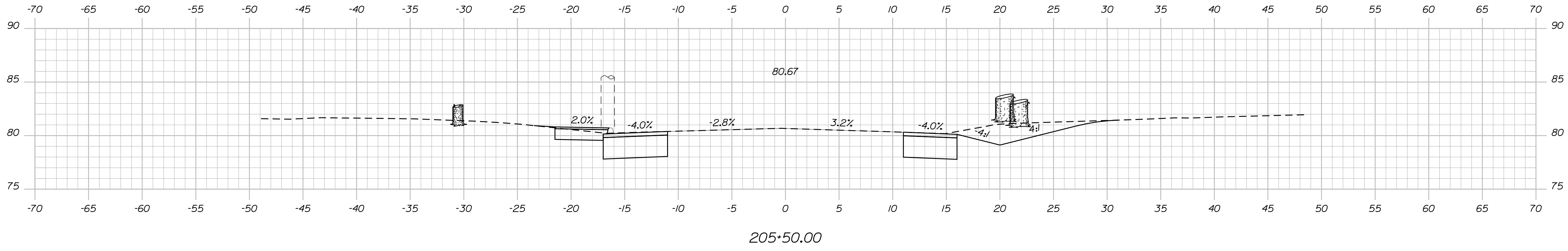

WORKING CROSS SECTIONS -
MODEL HAS NOT BEEN FULLY
DEVELOPED

STATE OF MAINE
DEPARTMENT OF TRANSPORTATION

ELIOT
ROUTE 103 YORK COUNTY

| | | | | | |
|------------------|-------------|------------------|-----------|-------------|---------|
| PROJ. MANAGER | J. BRUBAKER | BY | T. WOLFEL | DATE | 06/2023 |
| CHECKED-REVIEWED | L. MEEK | CHL | LEM | SIGNATURE | |
| DESIGNS DETAILED | | DESIGNS DETAILED | | P.E. NUMBER | |
| REVISIONS 1 | | REVISIONS 1 | | DATE | |
| REVISIONS 2 | | REVISIONS 2 | | | |
| REVISIONS 3 | | REVISIONS 3 | | | |
| REVISIONS 4 | | REVISIONS 4 | | | |
| FIELD CHANGES | | | | | |

CROSS SECTIONS

SHEET NUMBER

OS SHEET

OF 22

Sta. 204+50.00 to Sta. 205+50.00

Date: 7/21/2023

Username: twolfel

Division: HIGHWAY

Filename: ... \00\HIGHWAY\MSTA\sect.dgn

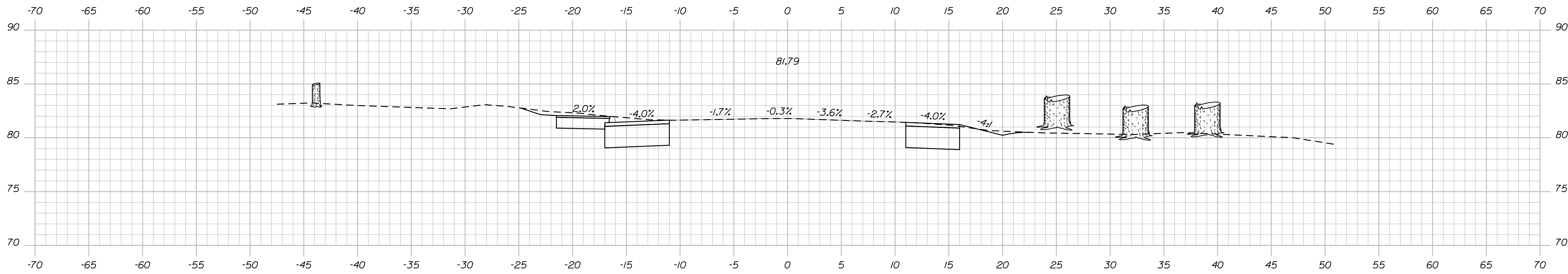

207+50.00

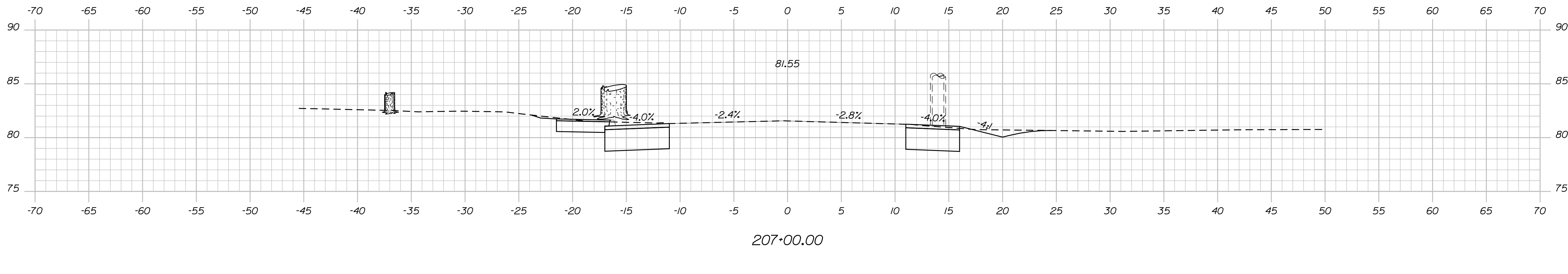

207+00.00

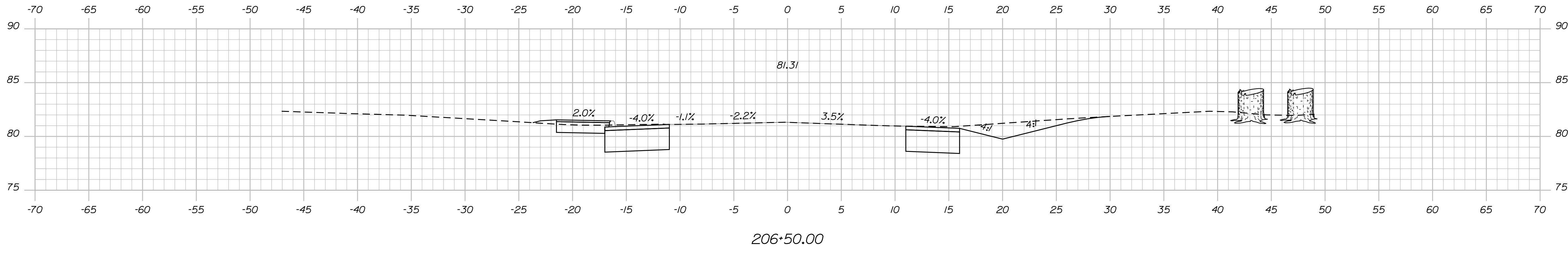

206+50.00

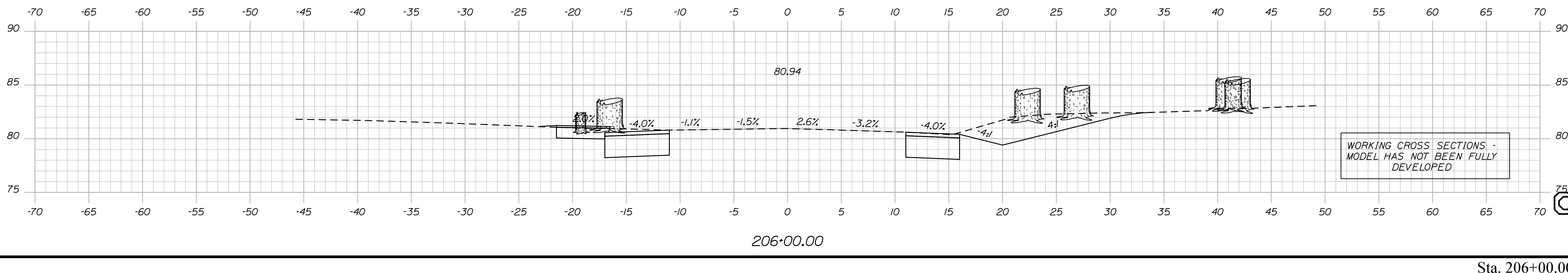

206+00.00

WORKING CROSS SECTIONS -
MODEL HAS NOT BEEN FULLY
DEVELOPED

STATE OF MAINE
DEPARTMENT OF TRANSPORTATION

SIGNATURE

DATE

BY

PROJ. MANAGER

CHECKED

DESIGNED

REVISIONS 1

REVISIONS 2

REVISIONS 3

REVISIONS 4

FIELD CHANGES

ELIOT

ROUTE 103

YORK COUNTY

ELIOT

CROSS SECTIONS

SHEET NUMBER

OF SHEET

OF 22

HIGHWAY PLANS

Date: 7/21/2023

Username: twolfel

Division: HIGHWAY

Filename: ... \00\HIGHWAY\MSTA\sect.dgn

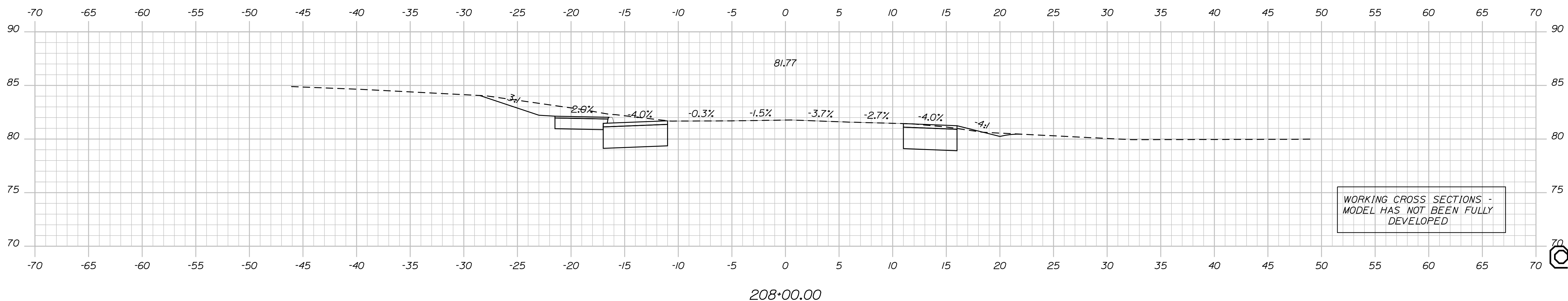
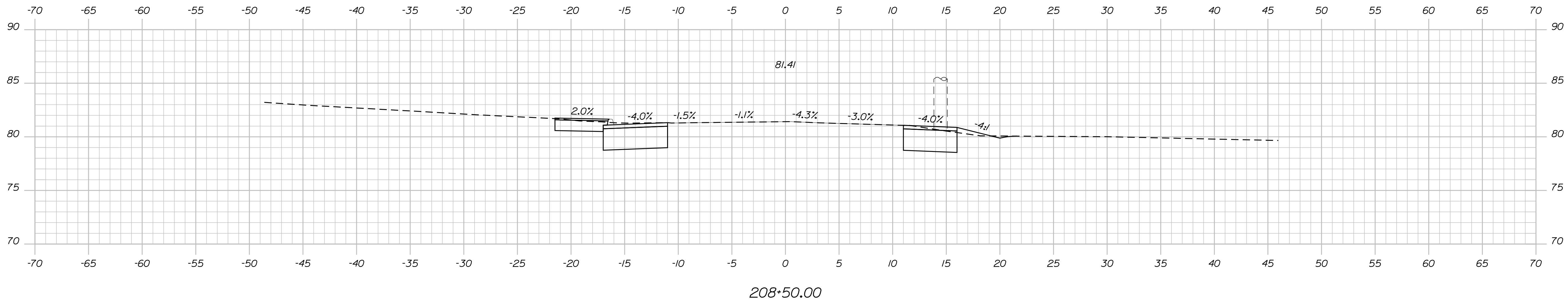
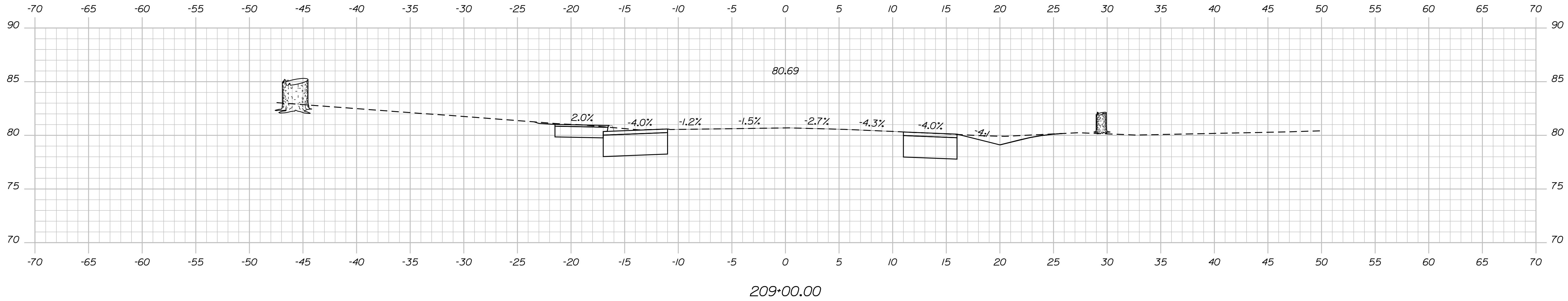

WORKING CROSS SECTIONS -
MODEL HAS NOT BEEN FULLY
DEVELOPED

STATE OF MAINE
DEPARTMENT OF TRANSPORTATION

ELIOT
ROUTE 103 YORK COUNTY

CROSS SECTIONS

PROJ. MANAGER: J. BRUBAKER
 DESIGN DETAILED: T. WOLFEL
 CHECKED/REVIEWED: L. MEEK
 DESIGNS DETAILED: L. MEEK
 REVISIONS 1:
 REVISIONS 2:
 REVISIONS 3:
 REVISIONS 4:
 FIELD CHANGES:

SHEET NUMBER
OF 22

OS SHEET

Date: 7/21/2023

Username: twolfel

Division: HIGHWAY

Filename: ... \00\HIGHWAY\MSTA\sect.dgn

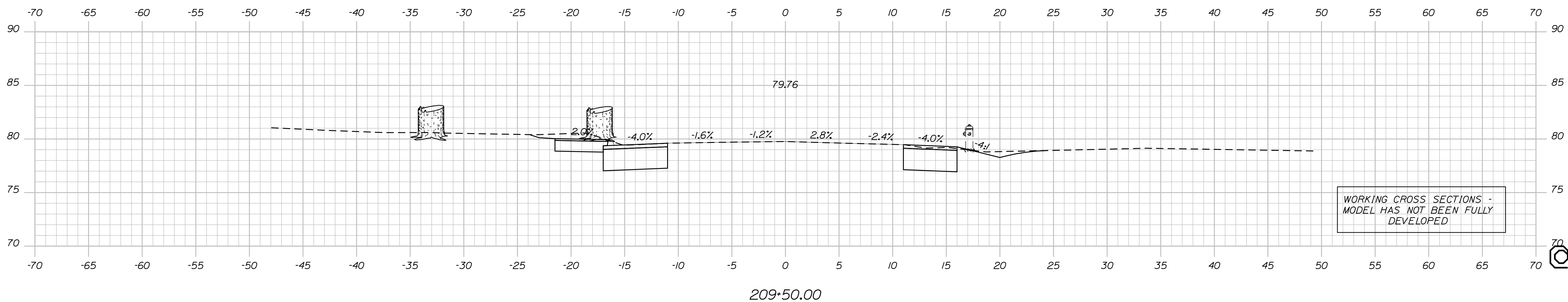
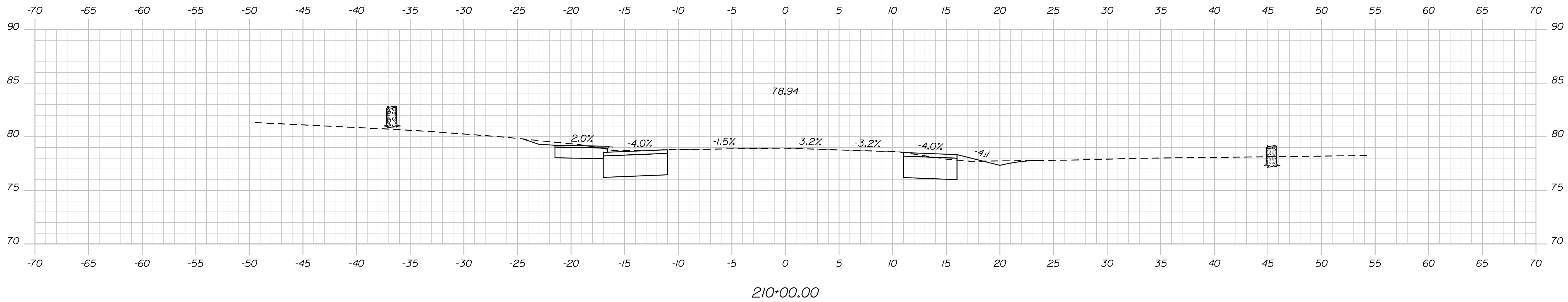
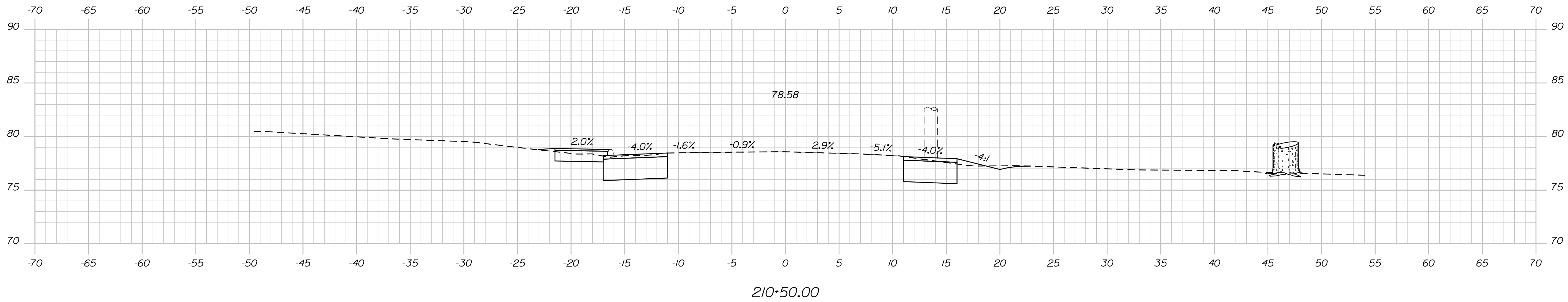

WORKING CROSS SECTIONS -
MODEL HAS NOT BEEN FULLY
DEVELOPED

STATE OF MAINE
DEPARTMENT OF TRANSPORTATION

ELIOT
ROUTE 103 YORK COUNTY

CROSS SECTIONS

SHEET NUMBER

OF 22

HIGHWAY PLANS

DATE: 06/20/23
SIGNATURE:
P.E. NUMBER:
DATE:

| PROJ. MANAGER | BY | DATE |
|------------------|-----------|----------|
| J. BRUBAKER | T. WOLFEL | 06/20/23 |
| CHECKED-REVIEWED | CHL | |
| DESIGN-REVIEWED | LEM | |
| DESIGN-REVIEWED | L. MEEK | |
| DESIGN-REVIEWED | | |
| REVISIONS 1 | | |
| REVISIONS 2 | | |
| REVISIONS 3 | | |
| REVISIONS 4 | | |
| FIELD CHANGES | | |

OS SHEET

Date: 7/21/2023

Username: twolfel

Division: HIGHWAY

Filename: ... \00\HIGHWAY\MSTA\sect.dgn

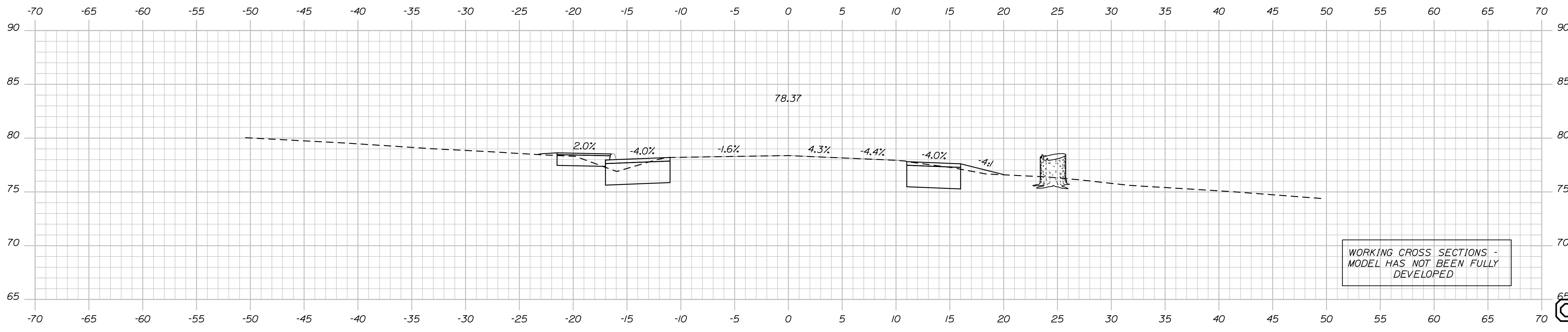
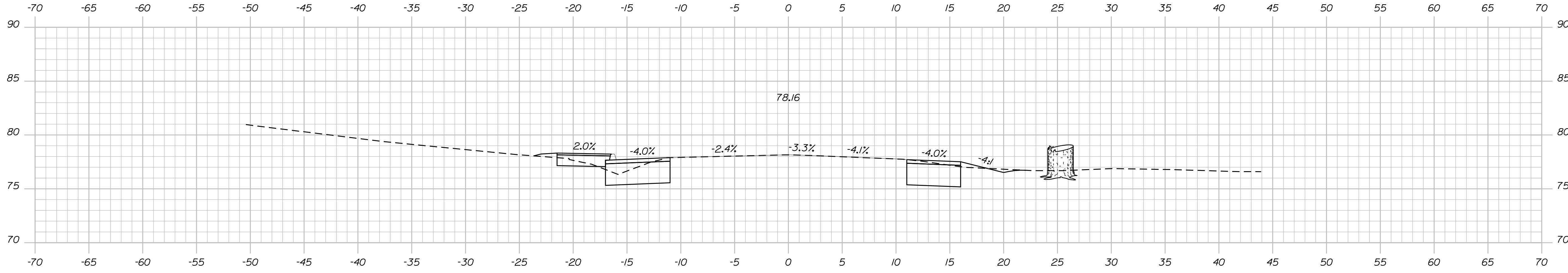
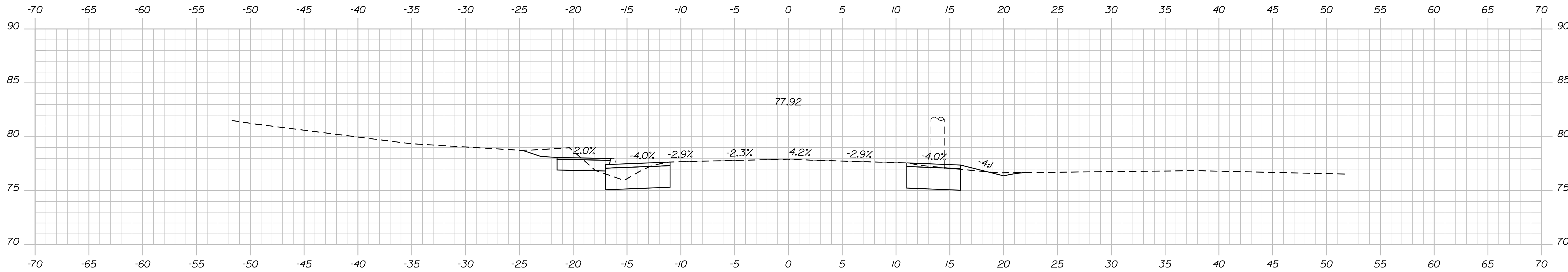

WORKING CROSS SECTIONS -
MODEL HAS NOT BEEN FULLY
DEVELOPED

STATE OF MAINE
DEPARTMENT OF TRANSPORTATION

ELIOT
ROUTE 103 YORK COUNTY

| PROJ. MANAGER | BY | DATE |
|------------------|-----------|-------------|
| J. BRUBAKER | T. WOLFEL | 06/20/23 |
| CHECKED-REVIEWED | CHL | SIGNATURE |
| DESIGN-REVIEWED | LEM | P.E. NUMBER |
| DESIGN-REVIEWED | | DATE |
| REVISIONS 1 | | |
| REVISIONS 2 | | |
| REVISIONS 3 | | |
| REVISIONS 4 | | |
| FIELD CHANGES | | |

ELIOT
ROUTE 103 YORK COUNTY
CROSS SECTIONS

SHEET NUMBER

OF SHEET

OF 22

Date: 7/21/2023

Username: twolfel

Division: HIGHWAY

Filename: ... \00\HIGHWAY\MSTA\sect.dgn

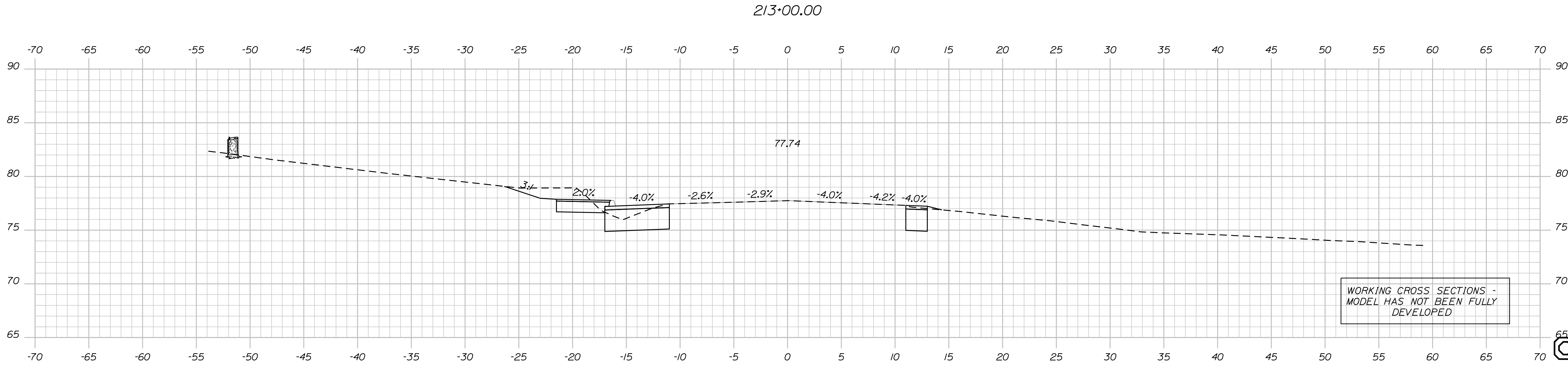
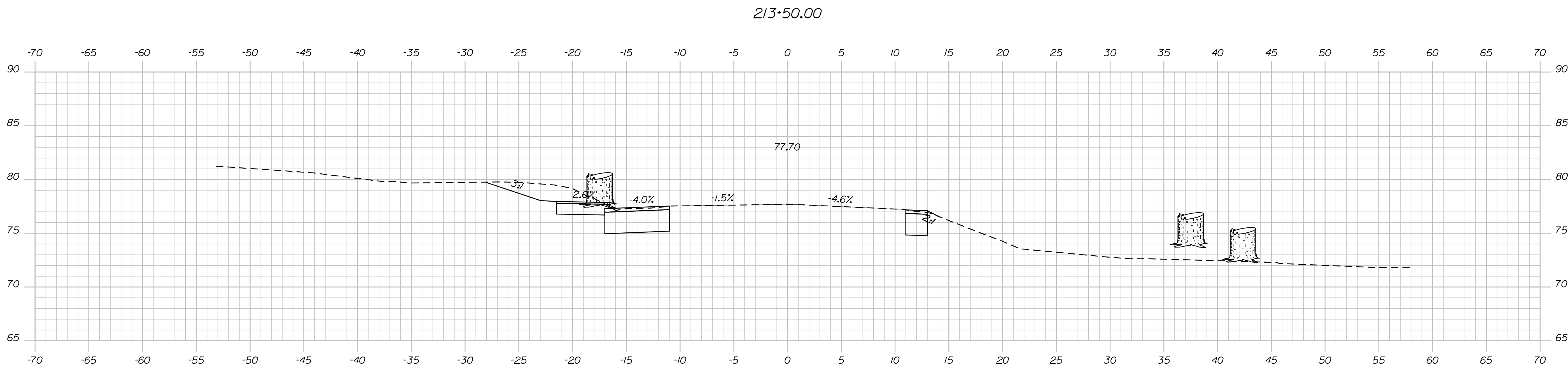
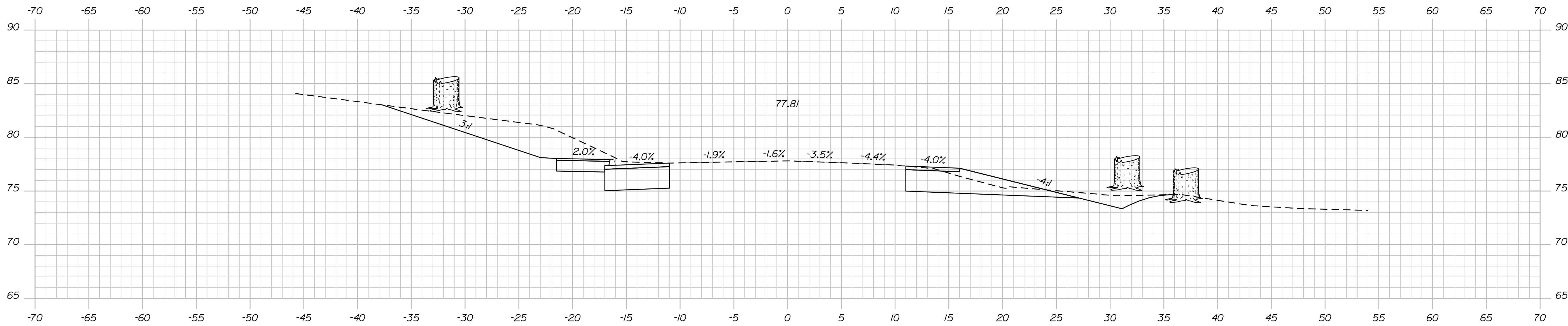

WORKING CROSS SECTIONS -
MODEL HAS NOT BEEN FULLY
DEVELOPED

STATE OF MAINE
DEPARTMENT OF TRANSPORTATION

ELIOT
ROUTE 103 YORK COUNTY

| PROJ. MANAGER | J. BRUBAKER | BY | DATE |
|------------------|-------------|-----|---------|
| DESIGN-DETAILED | T. WOLFEL | CHL | 06/2023 |
| CHECKED-REVIEWED | L. MEEK | LEM | |
| DESIGN-DETAILED | | | |
| REVISIONS 1 | | | |
| REVISIONS 2 | | | |
| REVISIONS 3 | | | |
| REVISIONS 4 | | | |
| FIELD CHANGES | | | |

CROSS SECTIONS

SHEET NUMBER

OS SHEET

Date: 7/21/2023

Username: twolfel

Division: HIGHWAY

Filename: ... \00\HIGHWAY\MSTA\sect.dgn

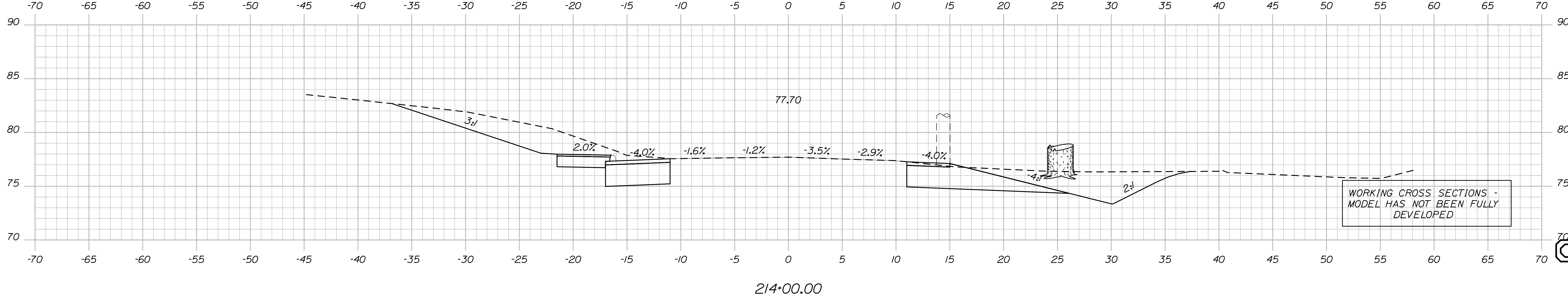
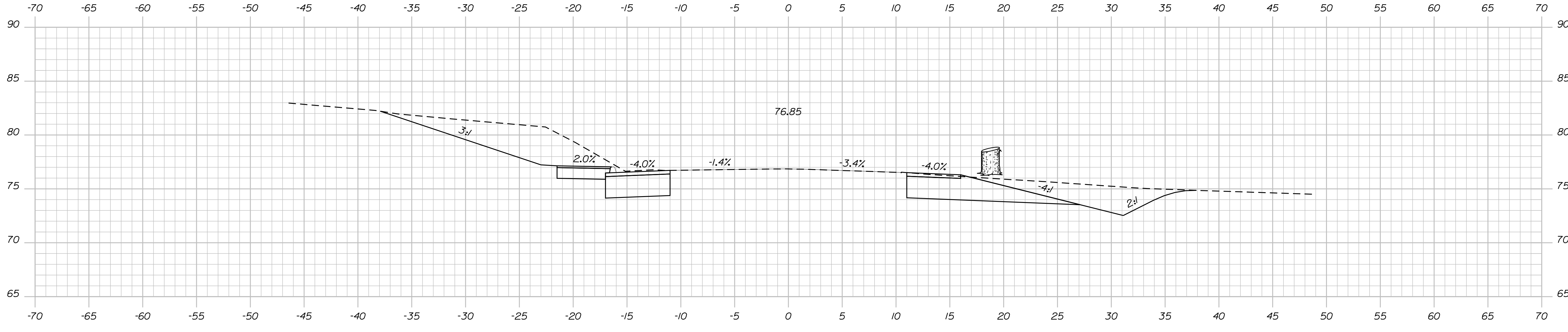
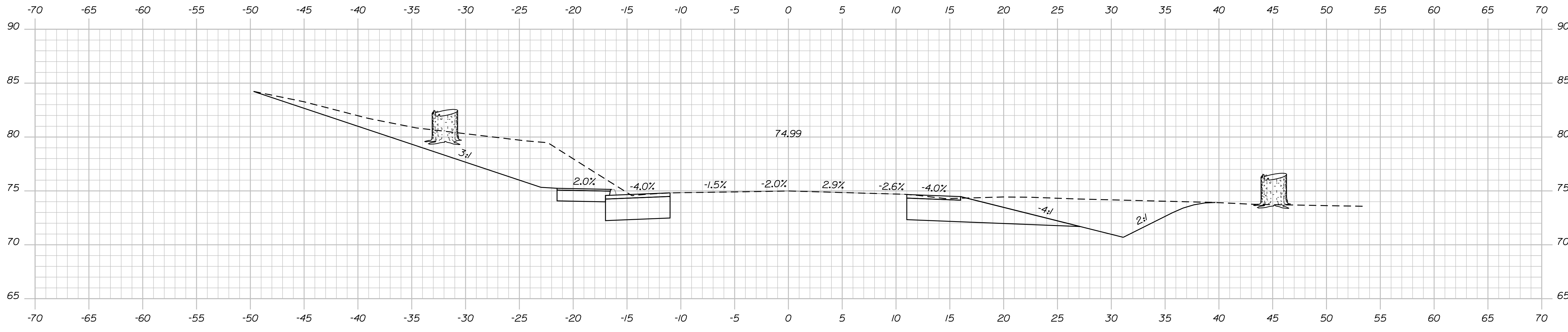

WORKING CROSS SECTIONS -
MODEL HAS NOT BEEN FULLY
DEVELOPED

STATE OF MAINE
DEPARTMENT OF TRANSPORTATION

ELIOT
ROUTE 103 YORK COUNTY

| PROJ. MANAGER | J. BRUBAKER | BY | DATE |
|------------------|-------------|-----|---------|
| DESIGN DETAILED | T. WOLFEL | CHL | 06/2023 |
| CHECKED/REVIEWED | L. MEEK | LEM | |
| DESIGN DETAILED | | | |
| REVISIONS 1 | | | |
| REVISIONS 2 | | | |
| REVISIONS 3 | | | |
| REVISIONS 4 | | | |
| FIELD CHANGES | | | |

CROSS SECTIONS

SHEET NUMBER

OS SHEET

OF 22

Date: 7/21/2023

Username: twolfel

Division: HIGHWAY

Filename: ... \00\HIGHWAY\MSTA\sect.dgn

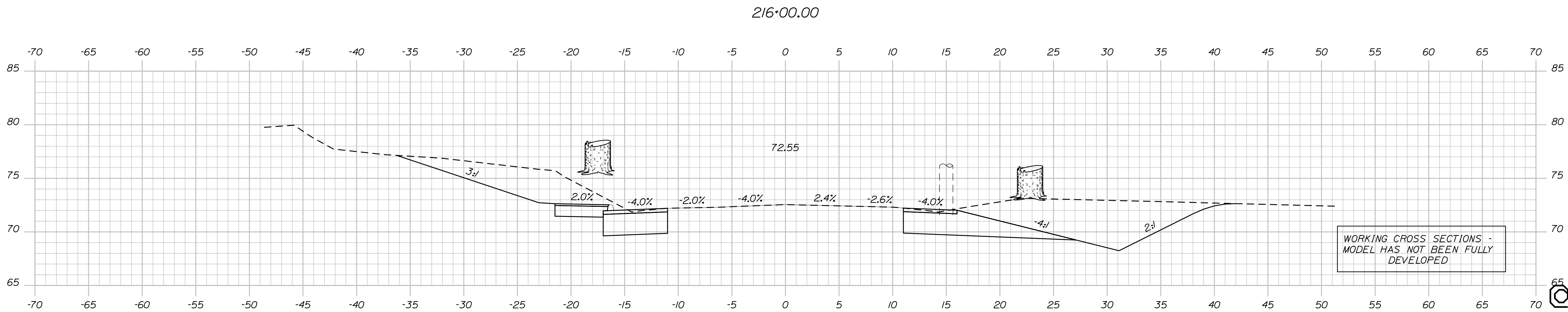
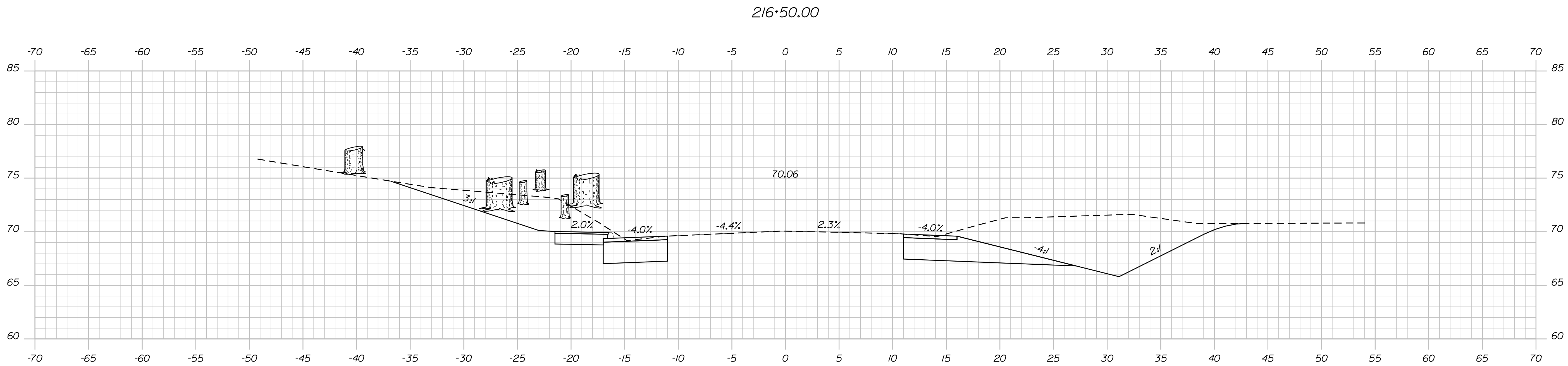
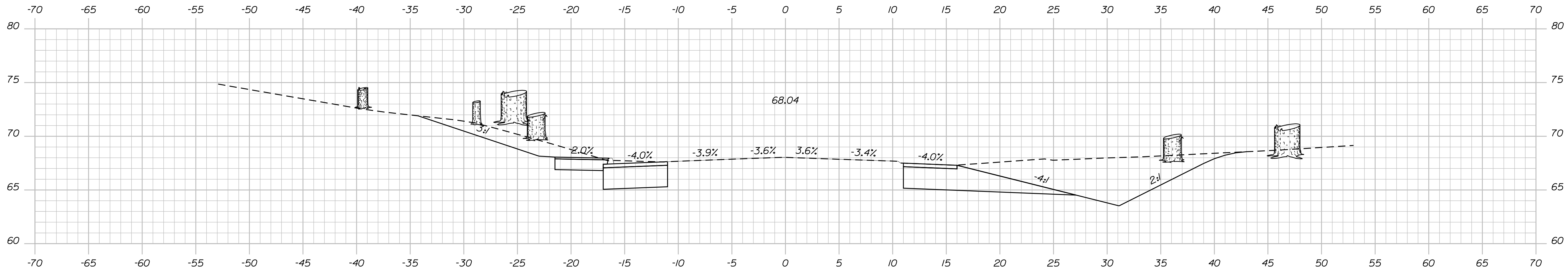

WORKING CROSS SECTIONS - MODEL HAS NOT BEEN FULLY DEVELOPED

STATE OF MAINE
DEPARTMENT OF TRANSPORTATION

ELIOT ROUTE 103 YORK COUNTY

| PROJ. MANAGER | J. BRUBAKER | BY | DATE |
|------------------|-------------|-----|---------|
| DESIGN DETAILED | T. WOLFEL | CHK | 06/2023 |
| CHECKED/REVIEWED | L. MEEK | LEM | |
| DESIGN DETAILED | | | |
| REVISIONS 1 | | | |
| REVISIONS 2 | | | |
| REVISIONS 3 | | | |
| REVISIONS 4 | | | |
| FIELD CHANGES | | | |

CROSS SECTIONS

SHEET NUMBER

OS SHEET

OF 22

Sta. 215+50.00 to Sta. 216+50.00

Date: 7/21/2023

Username: twolfel

Division: HIGHWAY

Filename: ... \00\HIGHWAY\MSTA\sect.dgn

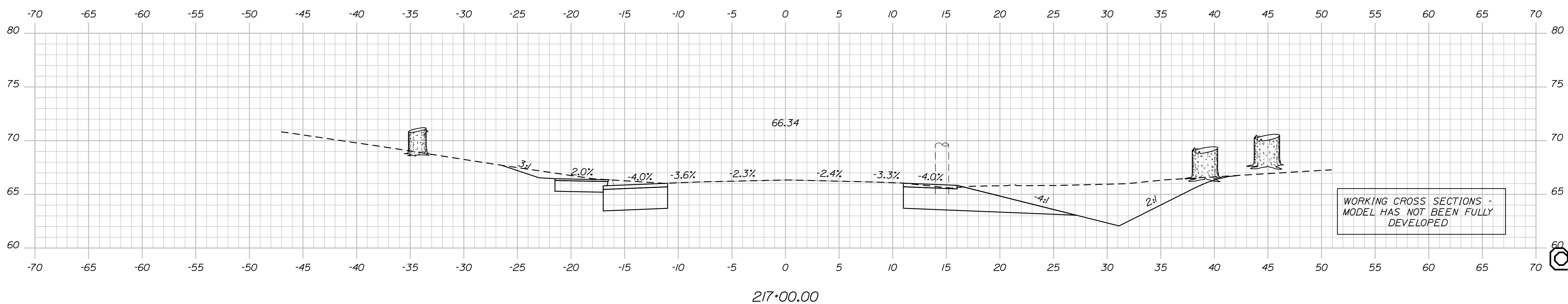
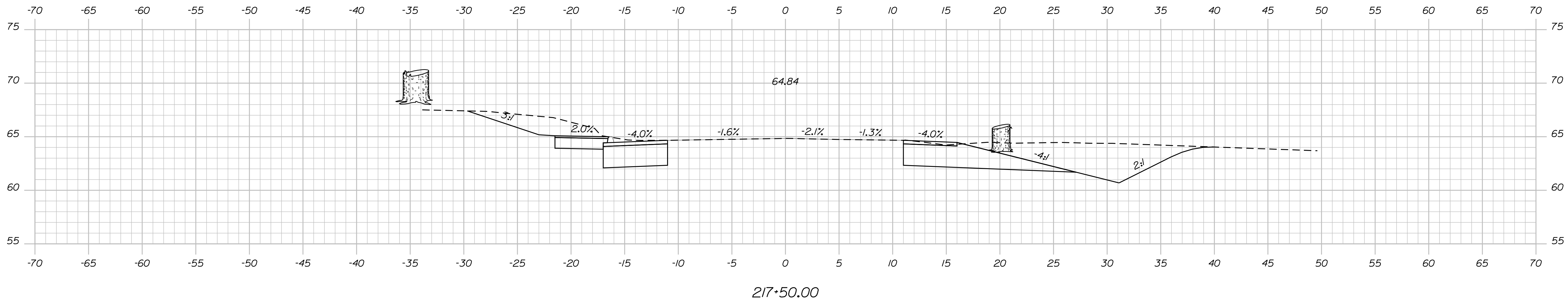
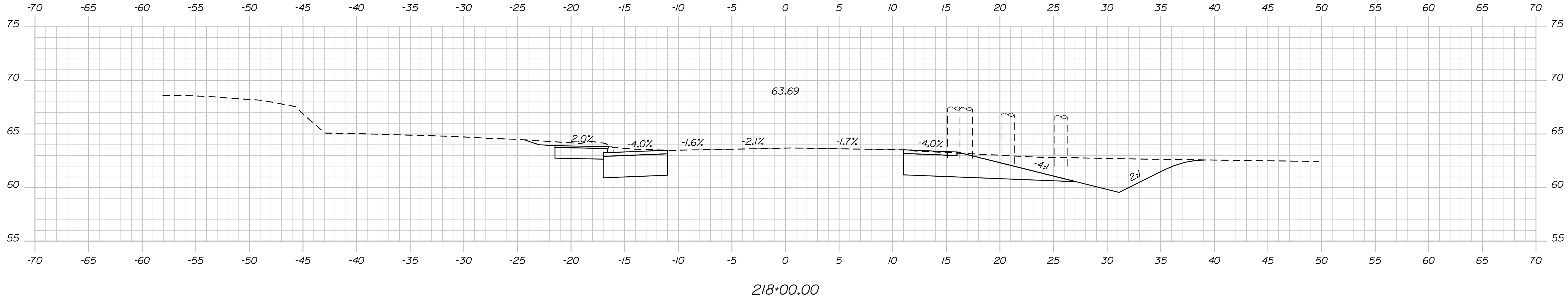

WORKING CROSS SECTIONS - MODEL HAS NOT BEEN FULLY DEVELOPED

| | | | | | |
|-----------------|-------------|------------------------------|-----------|----------------|---------|
| STATE OF MAINE | | DEPARTMENT OF TRANSPORTATION | | HIGHWAY PLANS | |
| ELIOT | | ROUTE 103 YORK COUNTY | | CROSS SECTIONS | |
| PROJ. MANAGER | J. BRUBAKER | BY | T. WOLFEL | DATE | 06/2023 |
| DESIGN DETAILED | T. WOLFEL | CHECKED | L. MEEK | SIGNATURE | |
| DESIGN REVIEWED | L. MEEK | DESIGN DETAILED | | P.E. NUMBER | |
| DESIGN DETAILED | | DESIGN REVIEWED | | DATE | |
| REVISIONS 1 | | REVISIONS 2 | | | |
| REVISIONS 3 | | REVISIONS 4 | | | |
| FIELD CHANGES | | | | | |
| SHEET NUMBER | | | | | |
| OF SHEET | | | | | |
| OF 22 | | | | | |

Date: 7/21/2023

Username: twolfel

Division: HIGHWAY

Filename: ... \00\HIGHWAY\MSTA\sect.dgn

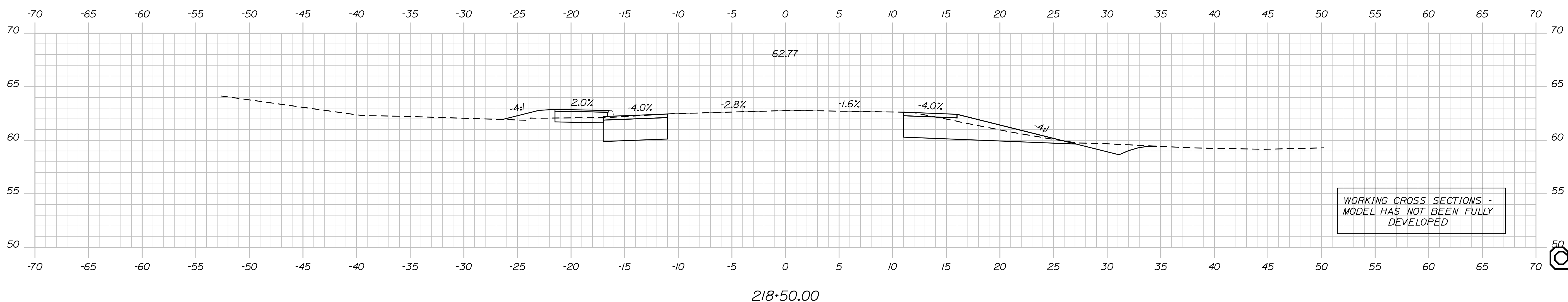
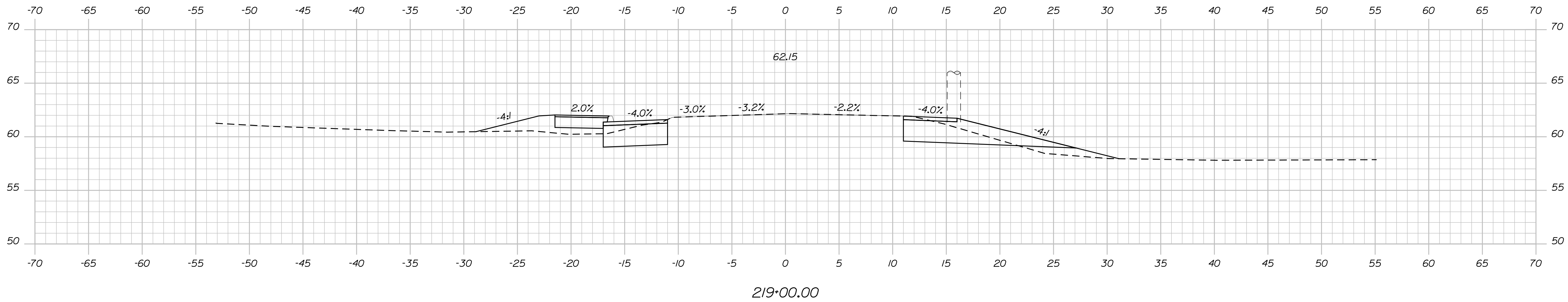
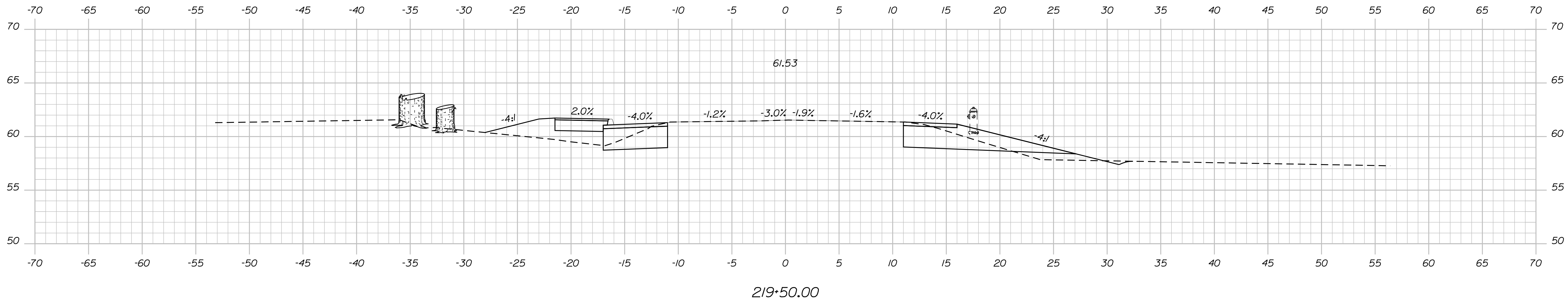

WORKING CROSS SECTIONS -
MODEL HAS NOT BEEN FULLY
DEVELOPED

STATE OF MAINE
DEPARTMENT OF TRANSPORTATION

ELIOT
ROUTE 103 YORK COUNTY

CROSS SECTIONS

SHEET NUMBER

OF 22

| | |
|---------------|------|
| DESIGNED | DATE |
| CHECKED | DATE |
| DESIGNED | DATE |
| REVISIONS 1 | DATE |
| REVISIONS 2 | DATE |
| REVISIONS 3 | DATE |
| REVISIONS 4 | DATE |
| FIELD CHANGES | DATE |

| | |
|---------------|-----|
| PROJ. MANAGER | BY |
| J. BRUBAKER | CHL |
| T. WOLFEL | LEM |
| L. WEEK | |

| | | |
|-----------|-------------|------|
| SIGNATURE | P.E. NUMBER | DATE |
| | | |

| | |
|------|----------|
| DATE | 06/20/23 |
|------|----------|

HIGHWAY PLANS

Date: 7/21/2023

Username: twolfel

Division: HIGHWAY

Filename: ... \00\HIGHWAY\MSTA\sect.dgn

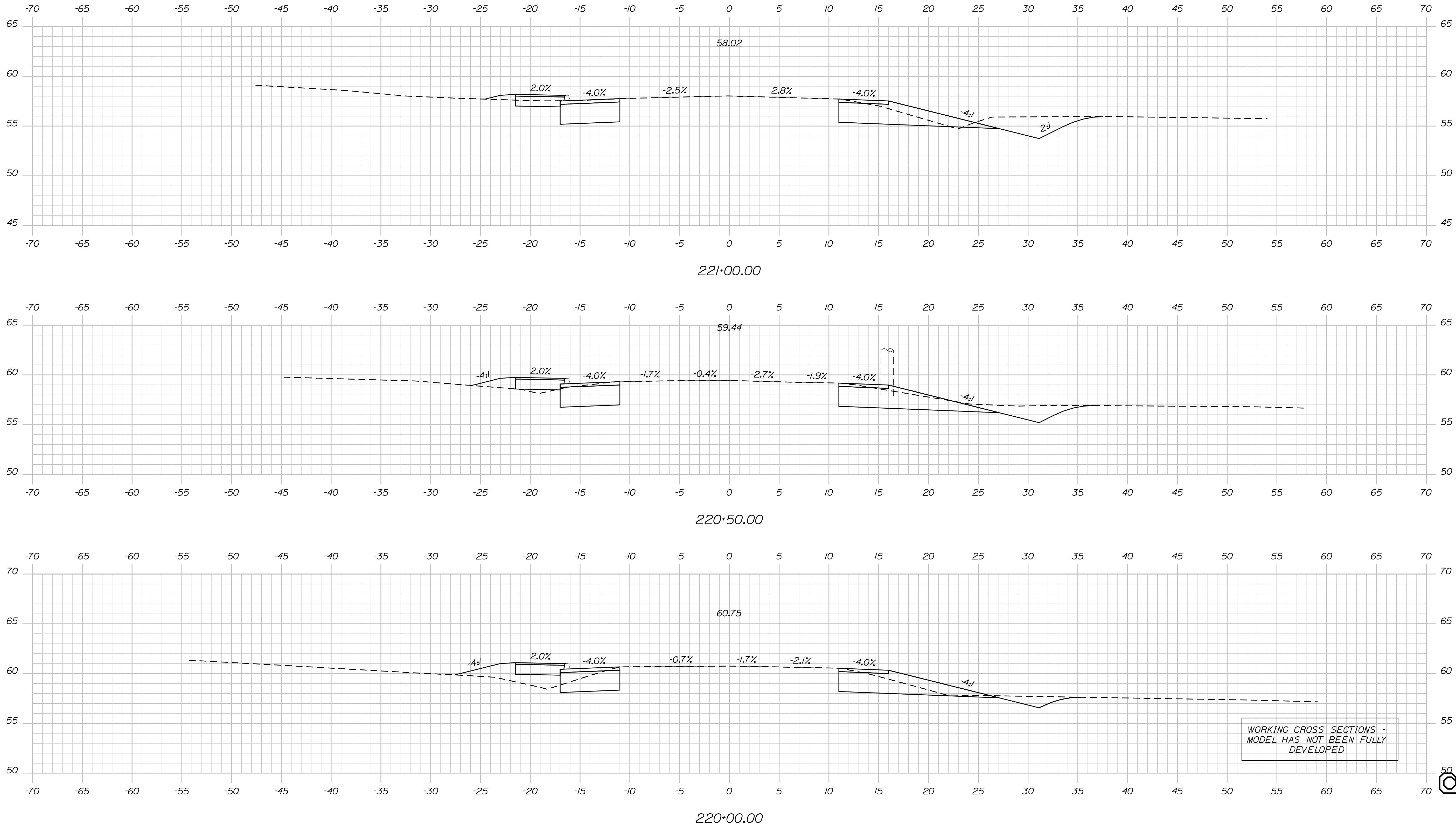

STATE OF MAINE
DEPARTMENT OF TRANSPORTATION

ELIOT
ROUTE 103 YORK COUNTY

CROSS SECTIONS

SHEET NUMBER

OF 22

HIGHWAY PLANS

| PROJ. MANAGER | BY | DATE |
|------------------|-----------|-------------|
| J. BRUBAKER | T. WOLFEL | 06/20/23 |
| DESIGN DETAILED | CHK | SIGNATURE |
| CHECKED/REVIEWED | LEM | P.E. NUMBER |
| DESIGN DETAILED | | DATE |
| REVISIONS 1 | | |
| REVISIONS 2 | | |
| REVISIONS 3 | | |
| REVISIONS 4 | | |
| FIELD CHANGES | | |

WORKING CROSS SECTIONS -
MODEL HAS NOT BEEN FULLY
DEVELOPED

Date: 7/21/2023

Username: twolfel

Division: HIGHWAY

Filename: ... \00\HIGHWAY\MSTA\sect.dgn

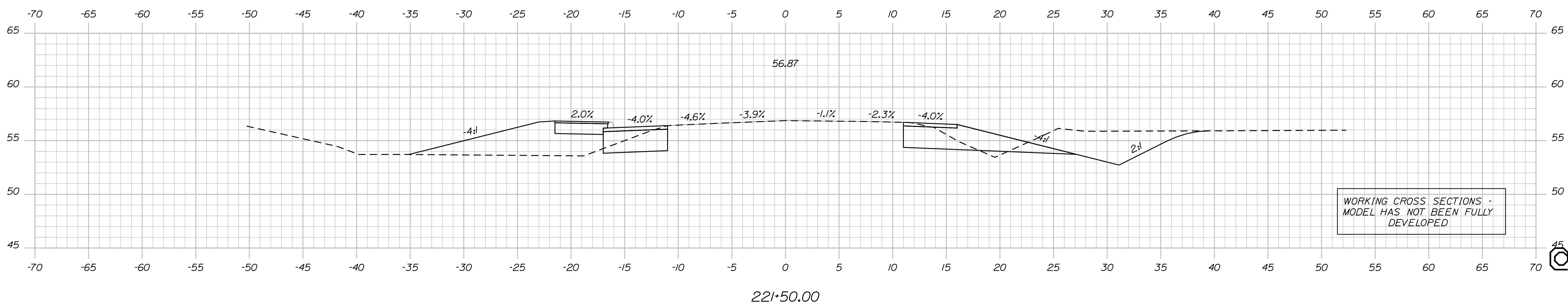
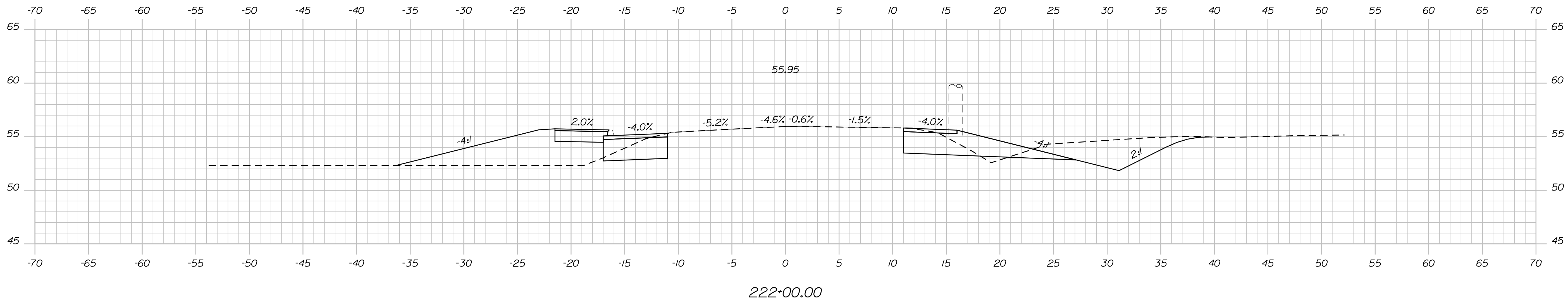
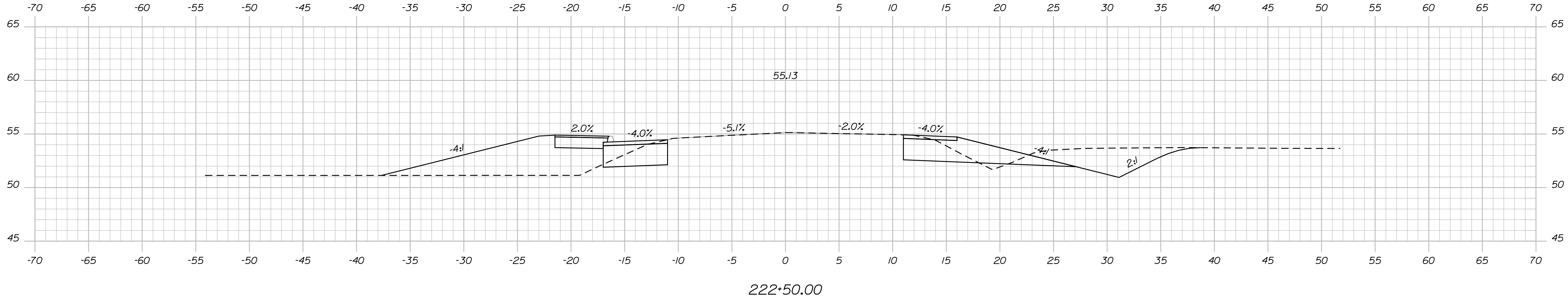

WORKING CROSS SECTIONS -
MODEL HAS NOT BEEN FULLY
DEVELOPED

STATE OF MAINE
DEPARTMENT OF TRANSPORTATION

ELIOT
ROUTE 103 YORK COUNTY

| PROJ. MANAGER | BY | DATE |
|------------------|-----------|-------------|
| J. BRUBAKER | T. WOLFEL | 06/2023 |
| CHECKED-REVIEWED | CHL | SIGNATURE |
| DESIGN-DETAILED | LEM | P.E. NUMBER |
| DESIGN-DETAILED | | DATE |
| REVISIONS 1 | | |
| REVISIONS 2 | | |
| REVISIONS 3 | | |
| REVISIONS 4 | | |
| FIELD CHANGES | | |

ELIOT
ROUTE 103 YORK COUNTY
CROSS SECTIONS

SHEET NUMBER

OF SHEET

OF 22

Sta. 221+50.00 to Sta. 222+50.00

Date: 7/21/2023

Username: twolfel

Division: HIGHWAY

Filename: ... \100\HIGHWAY\MSTA\vssect.dgn

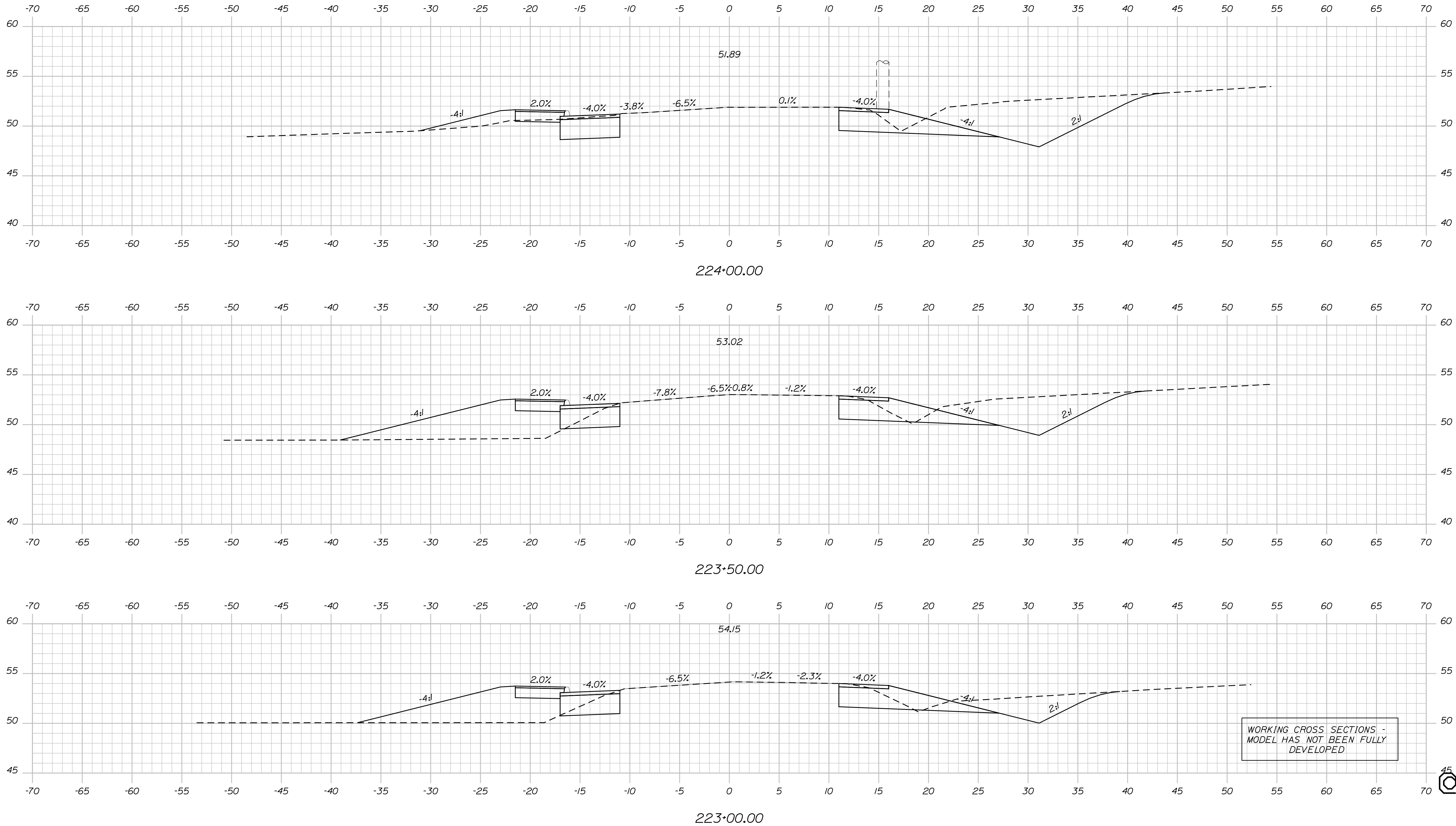

STATE OF MAINE
DEPARTMENT OF TRANSPORTATION

HIGHWAY PLANS

DATE
06/2023
SIGNATURE

BY
J. BRUBAKER
T. WOLFEL
L. MEEK

PROJ. MANAGER
DESIGN DETAILED
CHECKED-REVIEWED
DESIGN DETAILED
REVISIONS 1
REVISIONS 2
REVISIONS 3
REVISIONS 4
FIELD CHANGES

DATE
P.E. NUMBER
DATE

ELIOT
ROUTE 103 YORK COUNTY

CROSS SECTIONS

SHEET NUMBER

OF SHEET

OF 22

Sta. 223+00.00 to Sta. 224+00.00

Date: 7/21/2023

Username: twolfel

Division: HIGHWAY

Filename: ... \00\HIGHWAY\MSTA\sect.dgn

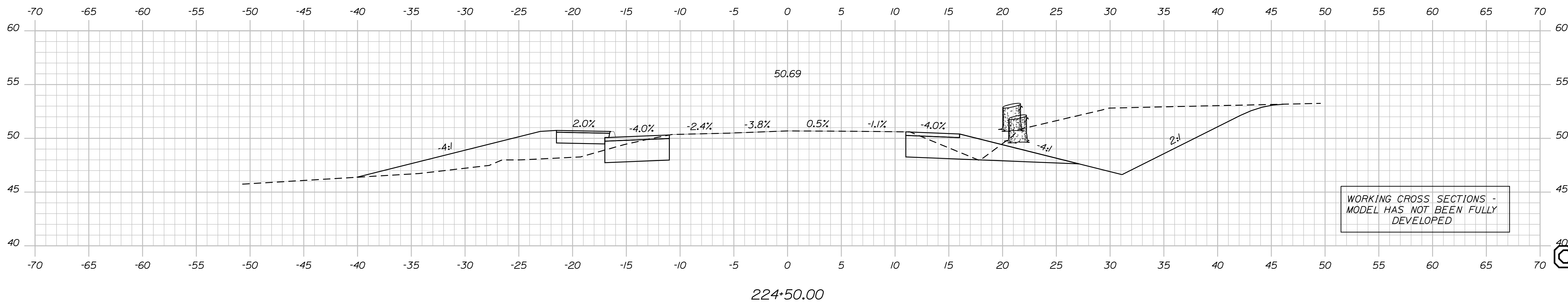
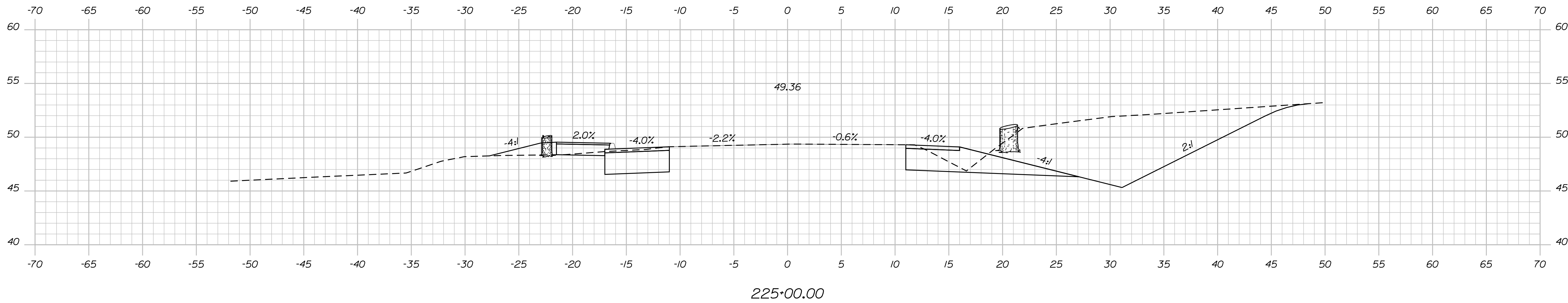
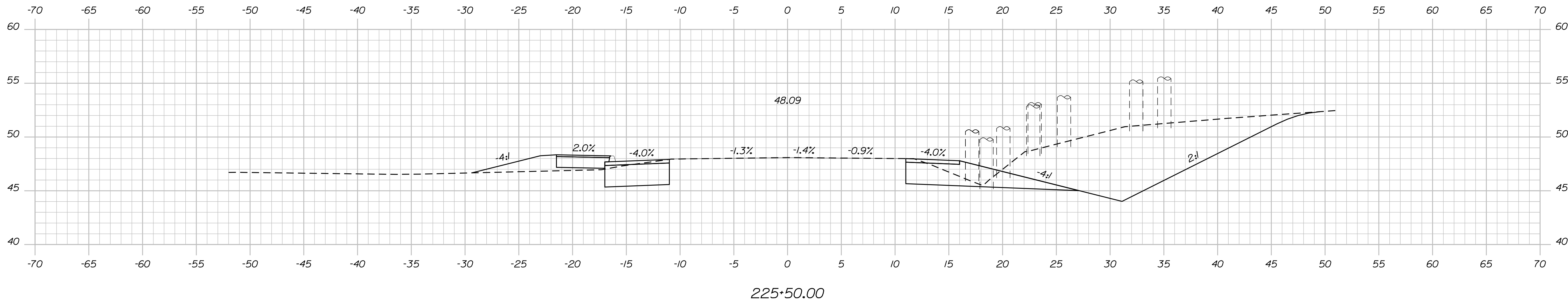

WORKING CROSS SECTIONS -
MODEL HAS NOT BEEN FULLY
DEVELOPED

STATE OF MAINE
DEPARTMENT OF TRANSPORTATION

ELIOT
ROUTE 103 YORK COUNTY

CROSS SECTIONS

PROJ. MANAGER: J. BRUBAKER
DESIGN-DETAILED: T. WOLFEL
CHECKED-REVIEWED: L. MEEK
DESIGN-DETAILED: L. MEEK
DESIGN-DETAILED: L. MEEK
REVISIONS 1:
REVISIONS 2:
REVISIONS 3:
REVISIONS 4:
FIELD CHANGES:

SHEET NUMBER
OF 22

HIGHWAY PLANS

OS SHEET

Date: 7/21/2023

Username: twolfel

Division: HIGHWAY

Filename: ... \00\HIGHWAY\MSTA\sect.dgn

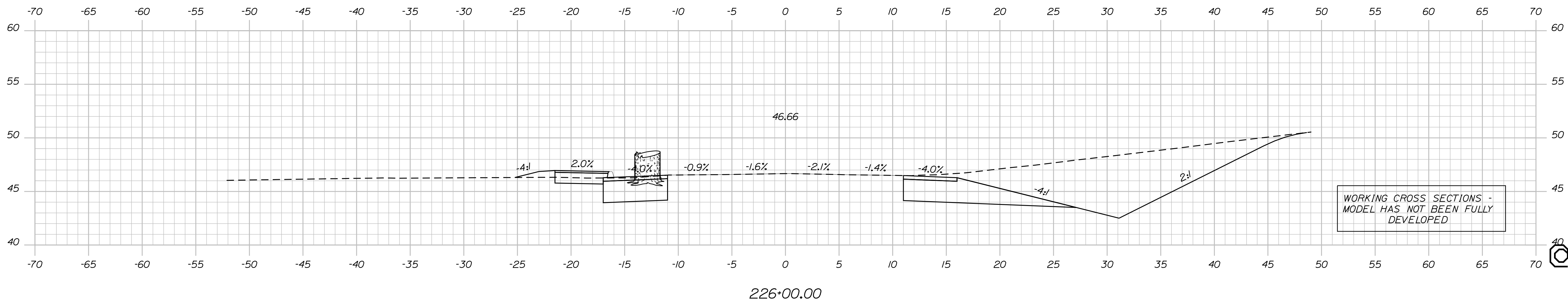
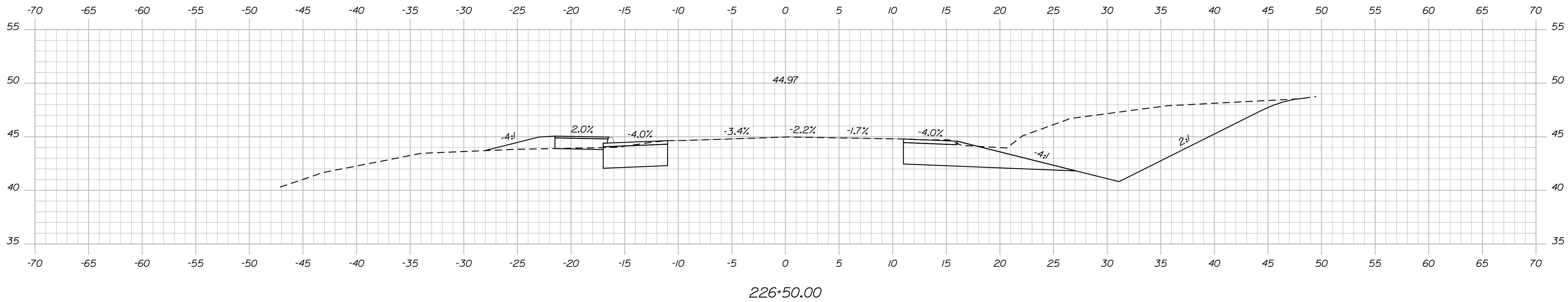
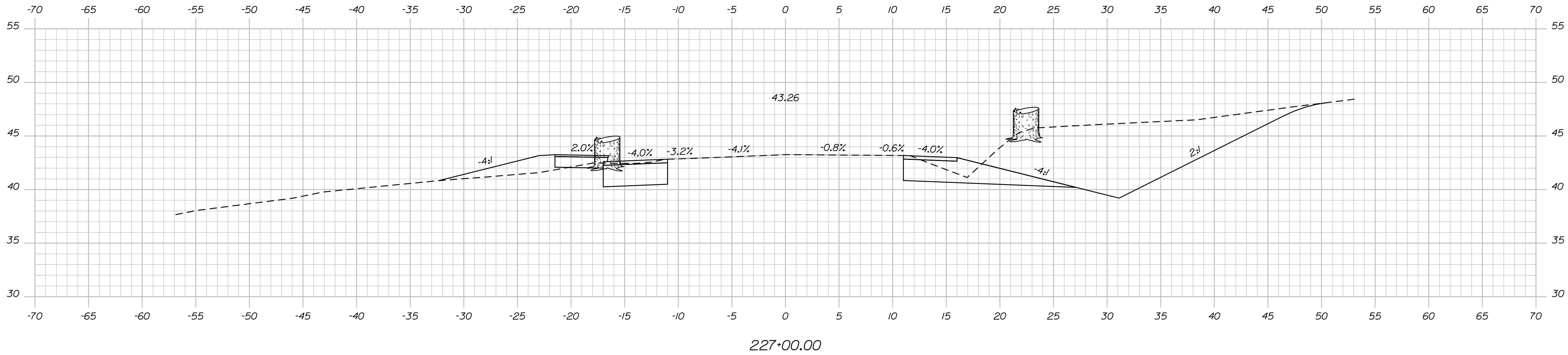

WORKING CROSS SECTIONS -
MODEL HAS NOT BEEN FULLY
DEVELOPED

STATE OF MAINE
DEPARTMENT OF TRANSPORTATION

ELIOT
ROUTE 103 YORK COUNTY

CROSS SECTIONS

PROJ. MANAGER: J. BRUBAKER
DESIGN DETAILED: T. WOLFEL
CHECKED/REVIEWED: L. MEEK
DESIGN DETAILED: L. MEEK
DESIGN DETAILED: L. MEEK
REVISIONS 1:
REVISIONS 2:
REVISIONS 3:
REVISIONS 4:
FIELD CHANGES:

SHEET NUMBER
OF 22

OS SHEET

Date: 7/21/2023

Username: twolfel

Division: HIGHWAY

Filename: ... \00\HIGHWAY\MSTA\sect.dgn

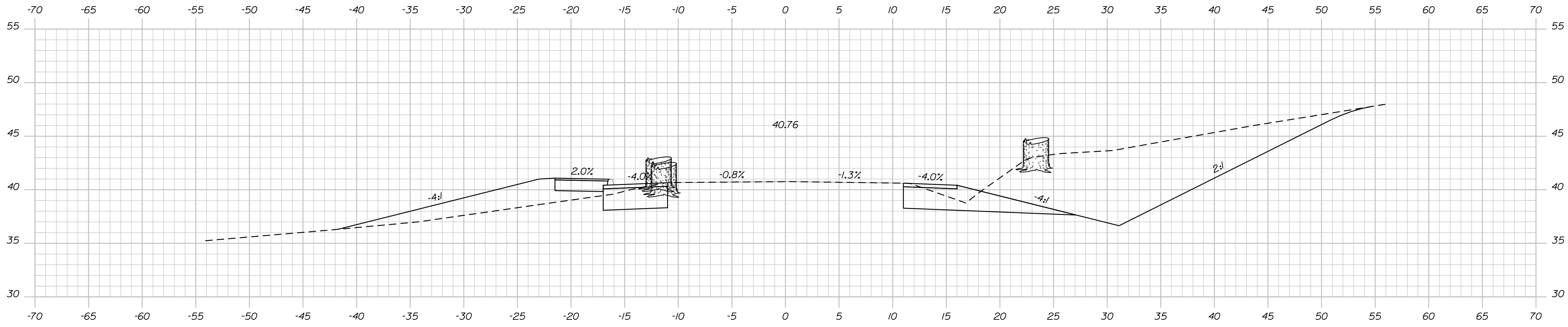

228+00.00

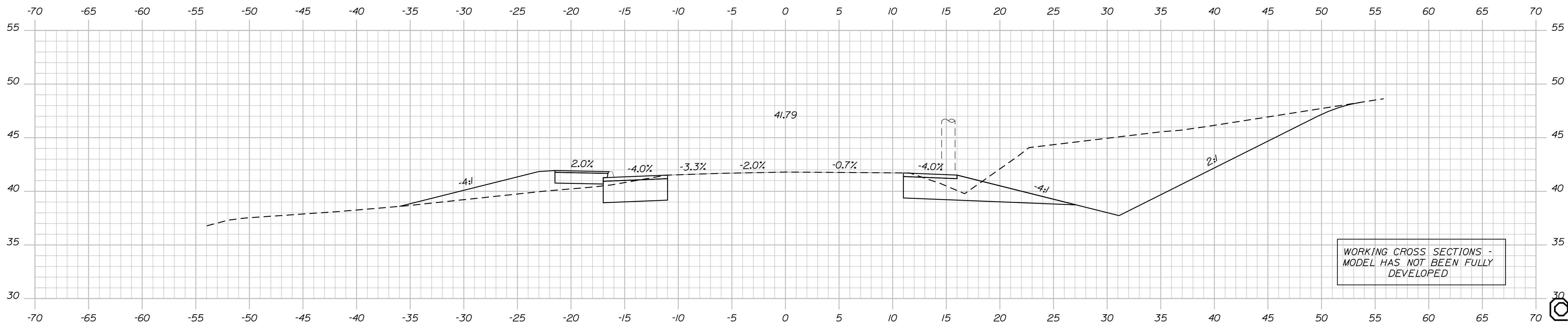

227+50.00

WORKING CROSS SECTIONS -
MODEL HAS NOT BEEN FULLY
DEVELOPED

STATE OF MAINE
DEPARTMENT OF TRANSPORTATION

ELIOT
ROUTE 103 YORK COUNTY

| | | | | | |
|------------------|-------------|----|-----|------|----------|
| PROJ. MANAGER | J. BRUBAKER | BY | CHL | DATE | |
| CHECKED-REVIEWED | T. WOLFEL | BY | LEM | DATE | 06/20/23 |
| DESIGN DETAILED | L. MEEK | BY | | DATE | |
| DESIGN DETAILED | | BY | | DATE | |
| REVISIONS 1 | | BY | | DATE | |
| REVISIONS 2 | | BY | | DATE | |
| REVISIONS 3 | | BY | | DATE | |
| REVISIONS 4 | | BY | | DATE | |
| FIELD CHANGES | | BY | | DATE | |

CROSS SECTIONS

SHEET NUMBER

OS SHEET

OF 22

Sta. 227+50.00 to Sta. 228+00.00

Date: 7/21/2023

Username: twolfel

Division: HIGHWAY

Filename: ... \00\HIGHWAY\MSTA\sect.dgn

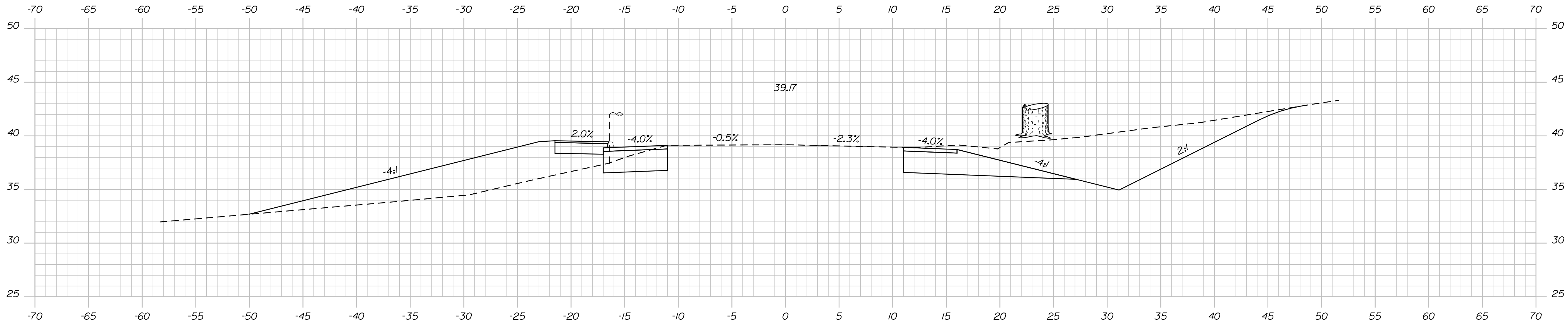

229+00.00

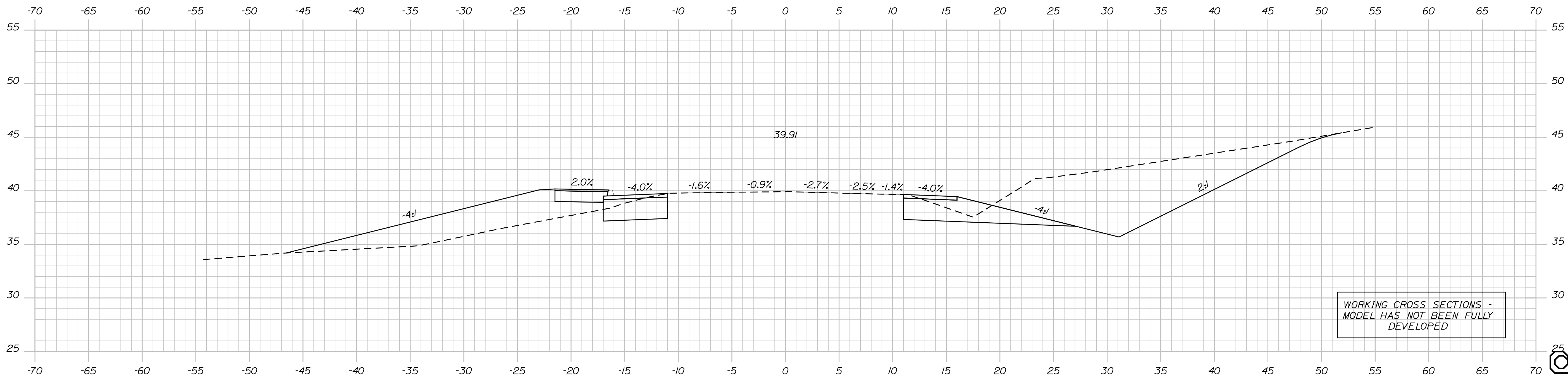

228+50.00

STATE OF MAINE
DEPARTMENT OF TRANSPORTATION

HIGHWAY PLANS

DATE
06/20/23

BY
CHL
LEM

PROJ. MANAGER
J. BRUBAKER

DESIGN-DETAILED
T. WOLFEL

CHECKED-REVIEWED
L. MEEK

DESIGN-DETAILED
L. MEEK

REVISIONS 1

REVISIONS 2

REVISIONS 3

REVISIONS 4

FIELD CHANGES

SIGNATURE

P.E. NUMBER

DATE

ELIOT
ROUTE 103 YORK COUNTY

CROSS SECTIONS

SHEET NUMBER

OF 22

Date: 7/21/2023

Username: twolfel

Division: HIGHWAY

Filename: ... \00\HIGHWAY\MSTA\sect.dgn

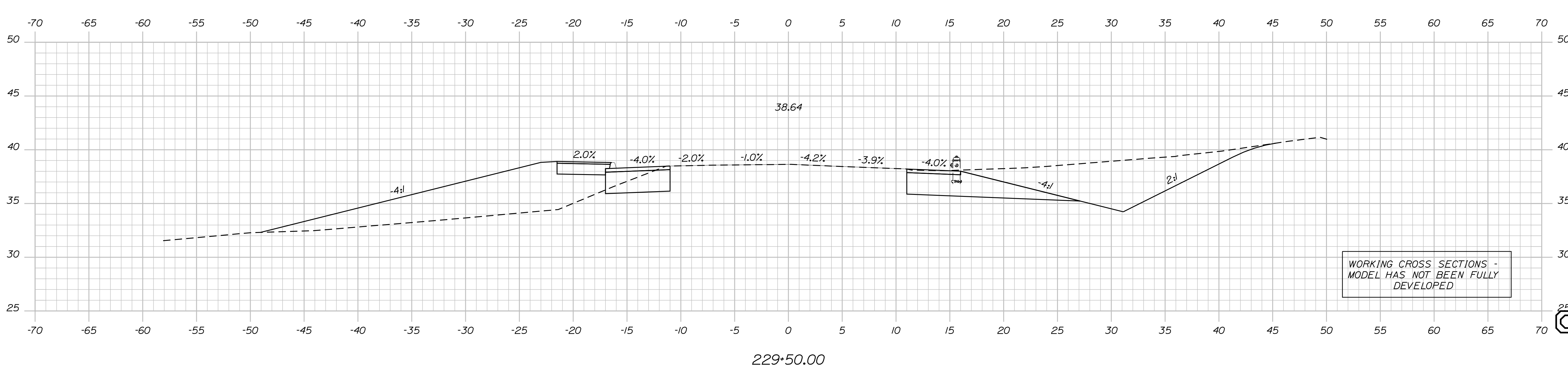
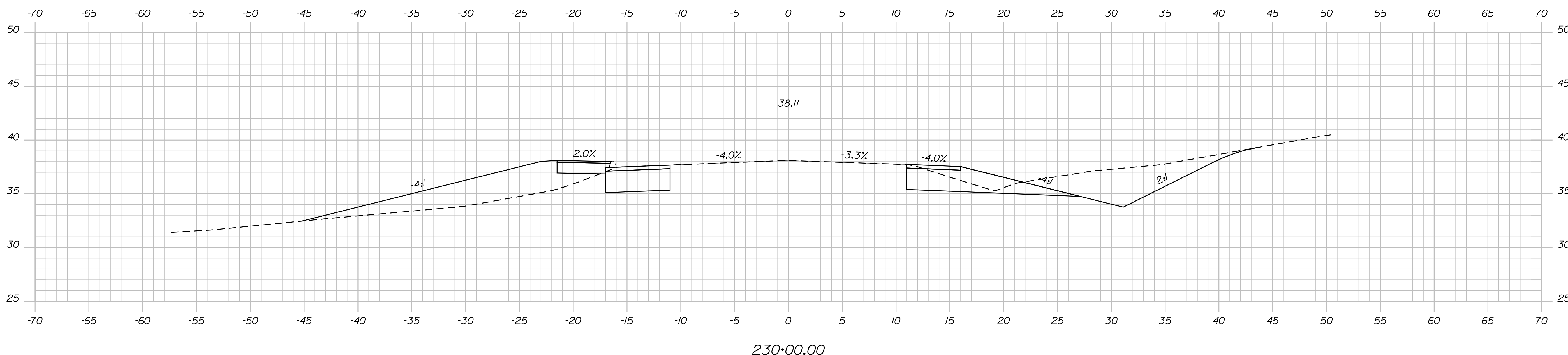
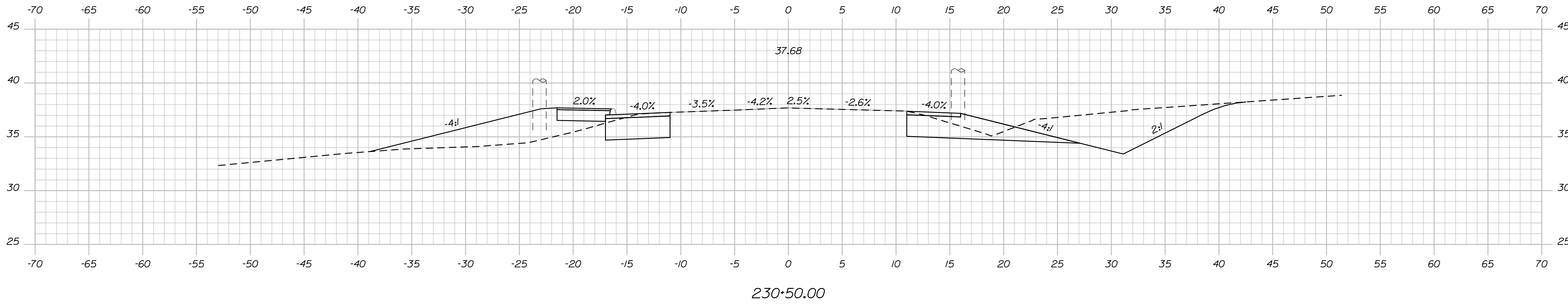

WORKING CROSS SECTIONS -
MODEL HAS NOT BEEN FULLY
DEVELOPED

STATE OF MAINE
DEPARTMENT OF TRANSPORTATION
HIGHWAY PLANS

ELIOT ROUTE 10 YORK COUNTY

| PROJ. MANAGER | J. BRUBAKER | BY | DATE |
|------------------|-------------|-----|----------|
| CHECKED-REVIEWED | T. WOLFEL | CHL | 06/20/23 |
| DESIGNS DETAILED | L. MEEK | LEM | |
| REVISIONS 1 | | | |
| REVISIONS 2 | | | |
| REVISIONS 3 | | | |
| REVISIONS 4 | | | |
| FIELD CHANGES | | | |

CROSS SECTIONS

SHEET NUMBER

OF SHEET

OF 22

Sta. 229+50.00 to Sta. 230+50.00

Date: 7/21/2023

Username: twolfel

Division: HIGHWAY

Filename: ... \00\HIGHWAY\MSTA\sect.dgn

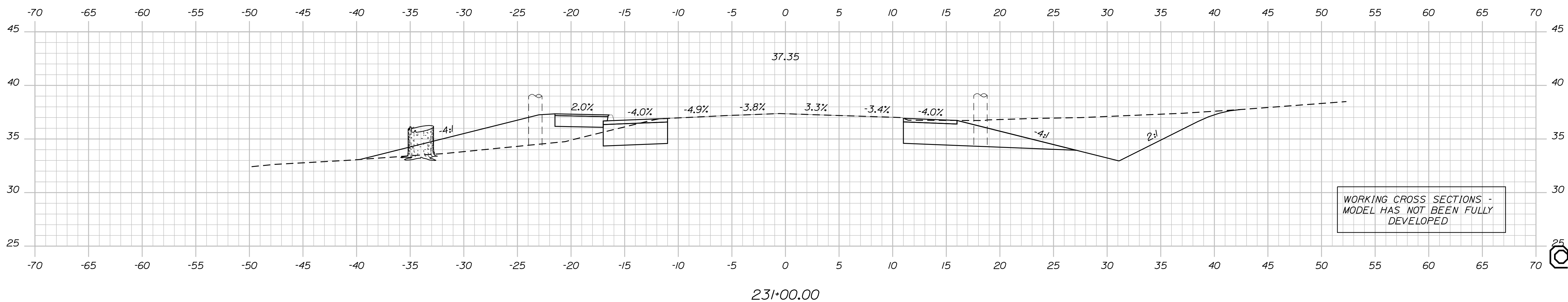
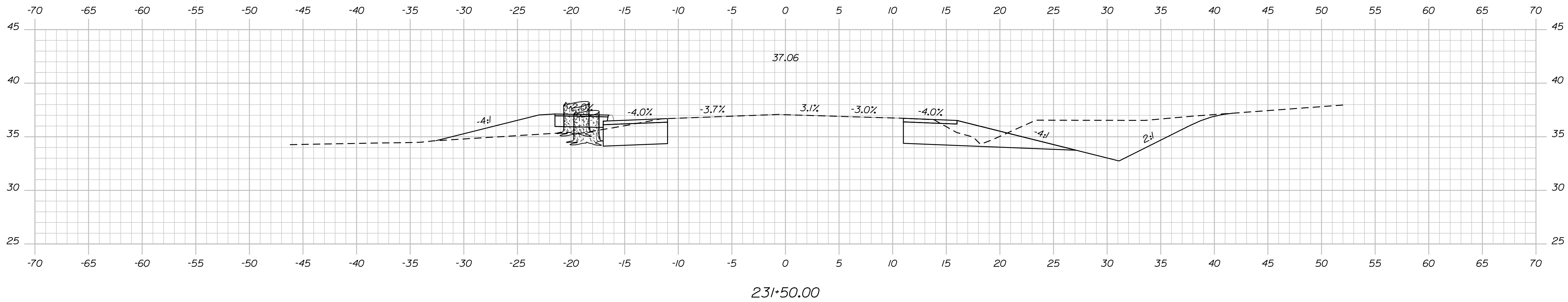
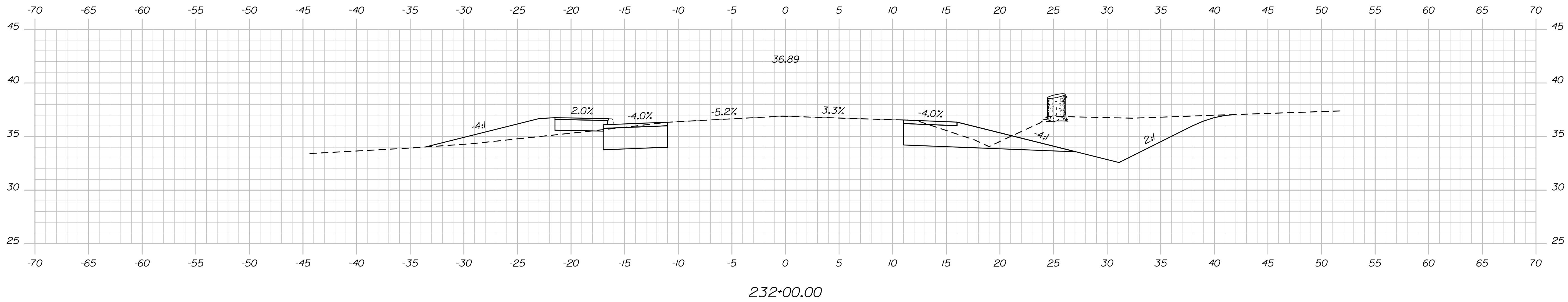

WORKING CROSS SECTIONS -
MODEL HAS NOT BEEN FULLY
DEVELOPED

STATE OF MAINE

DEPARTMENT OF TRANSPORTATION

HIGHWAY PLANS

DATE

06/2023

SIGNATURE

P.E. NUMBER

DATE

DATE

06/2023

BY

CHL

LEM

PROJ. MANAGER

J. BRUBAKER

T. WOLFEL

L. MEEK

DESIGN DETAILED

CHL

LEM

CHECKED/REVIEWED

T. WOLFEL

L. MEEK

DESIGN DETAILED

CHL

LEM

DESIGN DETAILED

CHL

LEM

REVISIONS 1

CHL

LEM

REVISIONS 2

CHL

LEM

REVISIONS 3

CHL

LEM

REVISIONS 4

CHL

LEM

FIELD CHANGES

CHL

LEM

ELIOT ROUTE 103 YORK COUNTY

CROSS SECTIONS

SHEET NUMBER

OF SHEET

OF 22

Sta. 231+00.00 to Sta. 232+00.00

Date: 7/21/2023

Username: twolfel

Division: HIGHWAY

Filename: ... \00\HIGHWAY\MSTA\sect.dgn

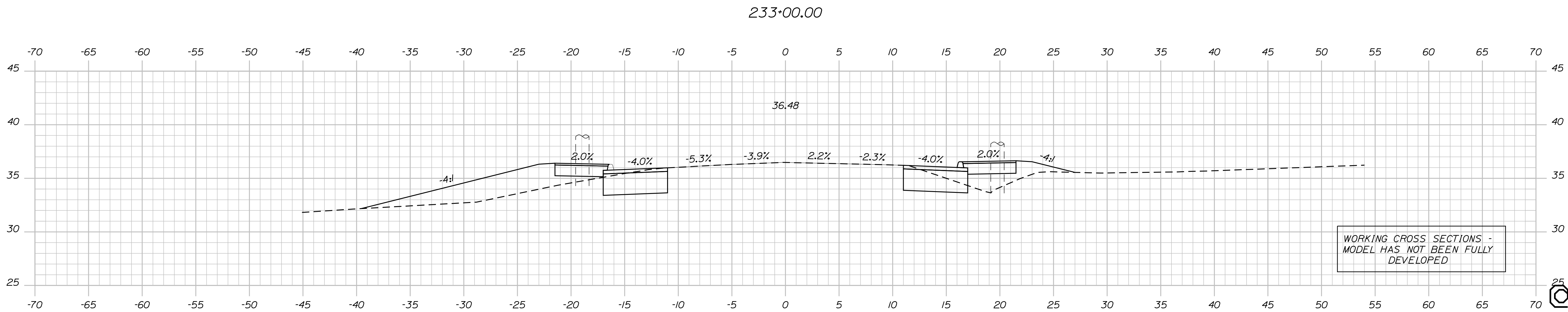
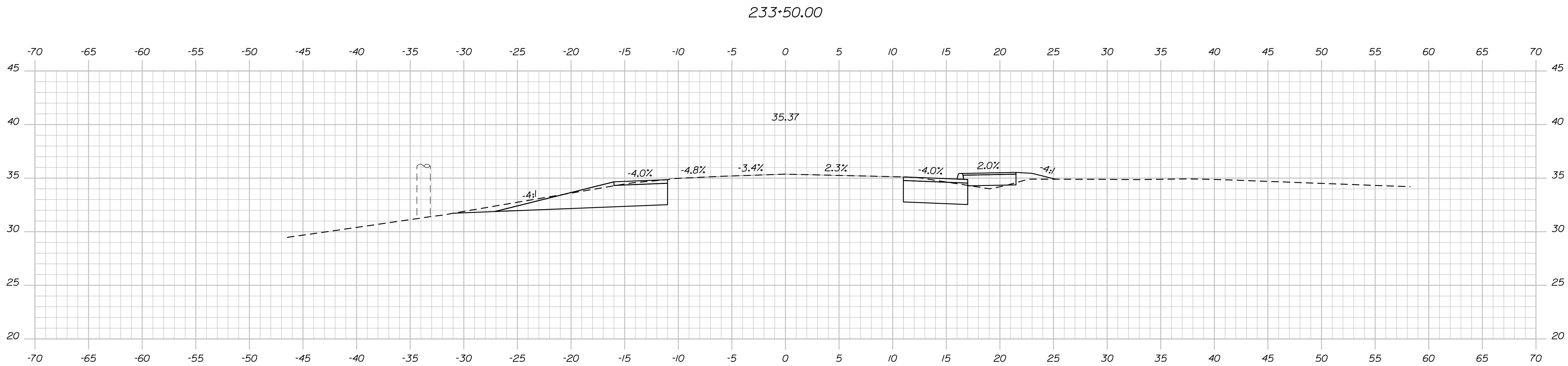
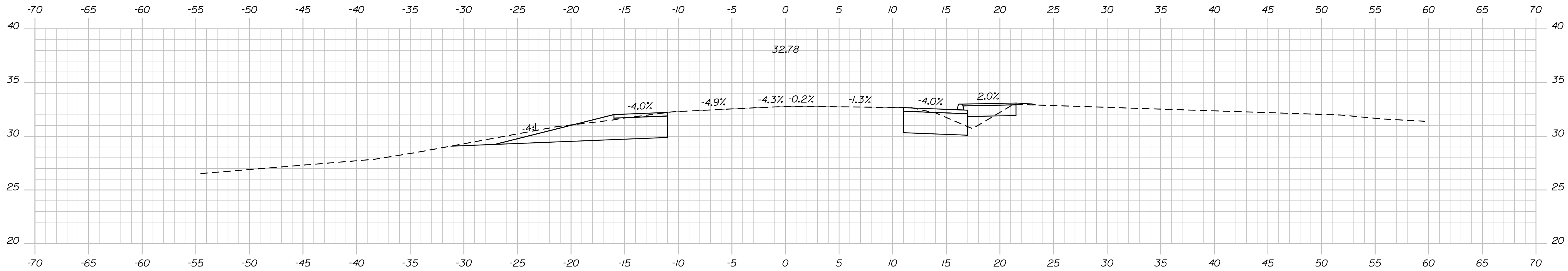

WORKING CROSS SECTIONS -
MODEL HAS NOT BEEN FULLY
DEVELOPED

STATE OF MAINE
DEPARTMENT OF TRANSPORTATION

ELIOT
ROUTE 103 YORK COUNTY

CROSS SECTIONS

SHEET NUMBER

OF 22

HIGHWAY PLANS

| PROJ. MANAGER | DATE | BY | DATE |
|------------------|------|-----------|----------|
| J. BRUBAKER | | J. WOLFEL | 06/20/23 |
| CHECKED-REVIEWED | | LEM | |
| DESIGN DETAILED | | | |
| DESIGN DETAILED | | | |
| REVISIONS 1 | | | |
| REVISIONS 2 | | | |
| REVISIONS 3 | | | |
| REVISIONS 4 | | | |
| FIELD CHANGES | | | |

SIGNATURE
P.E. NUMBER
DATE

Date: 7/21/2023

Username: twolfel

Division: HIGHWAY

Filename: ... \00\HIGHWAY\MSTA\sect.dgn

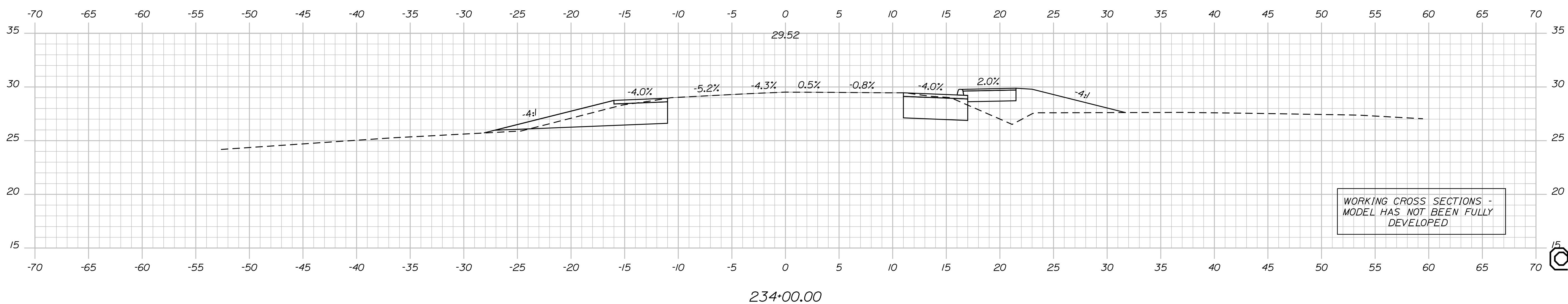
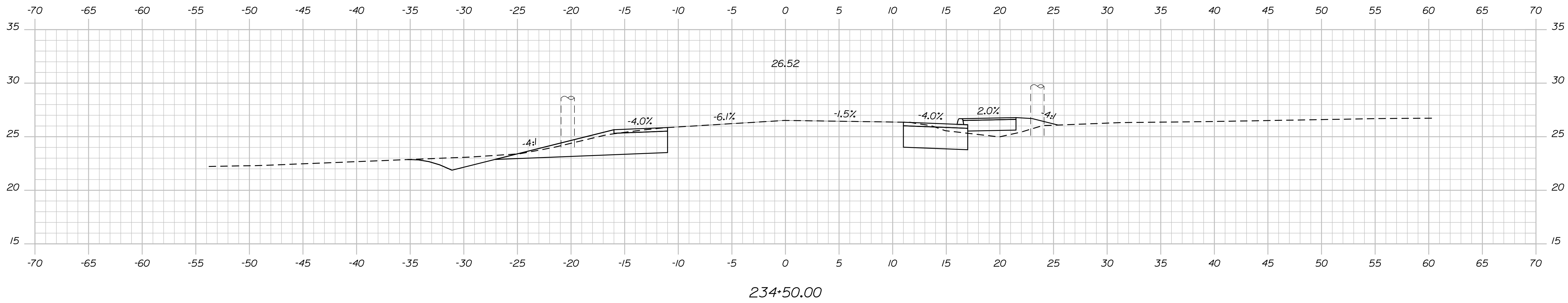
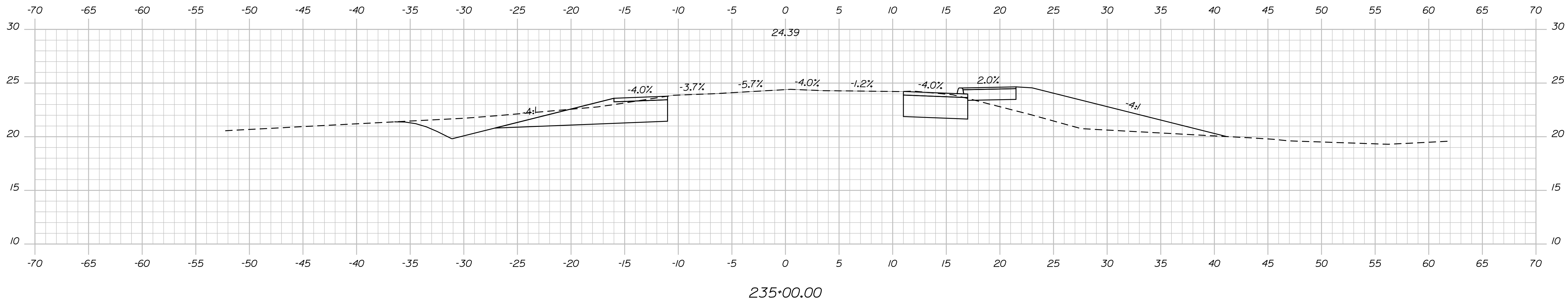

WORKING CROSS SECTIONS -
MODEL HAS NOT BEEN FULLY
DEVELOPED

STATE OF MAINE
DEPARTMENT OF TRANSPORTATION

ELIOT
ROUTE 103 YORK COUNTY

CROSS SECTIONS

SHEET NUMBER

OF 22

DESIGN/REVIEWED
CHECKED/REVIEWED
DESIGN/REVIEWED
REVISIONS 1
REVISIONS 2
REVISIONS 3
REVISIONS 4
FIELD CHANGES

PROJ. MANAGER
J. BRUBAKER

BY
T. WOLFEL
L. MEEK

DATE
06/2023

SIGNATURE

P.E. NUMBER

DATE

HIGHWAY PLANS

Date: 7/21/2023

Username: twolfel

Division: HIGHWAY

Filename: ... \00\HIGHWAY\MSTA\sect.dgn

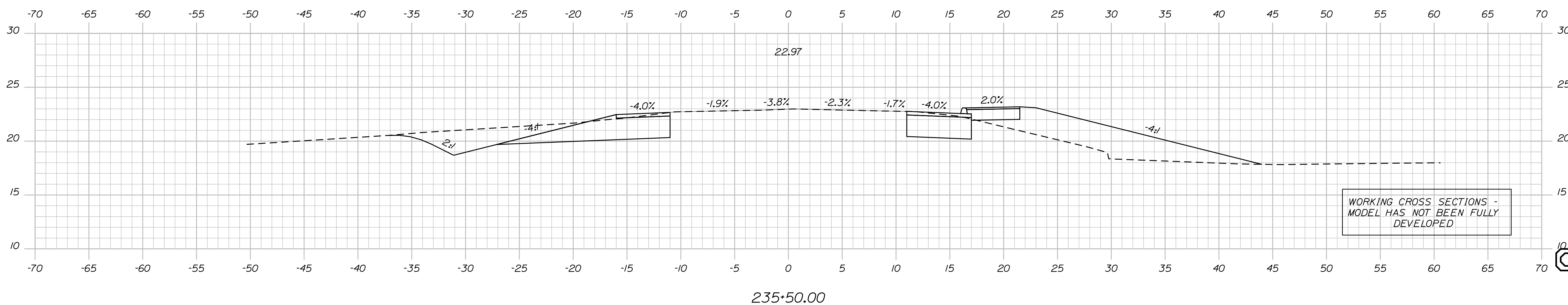
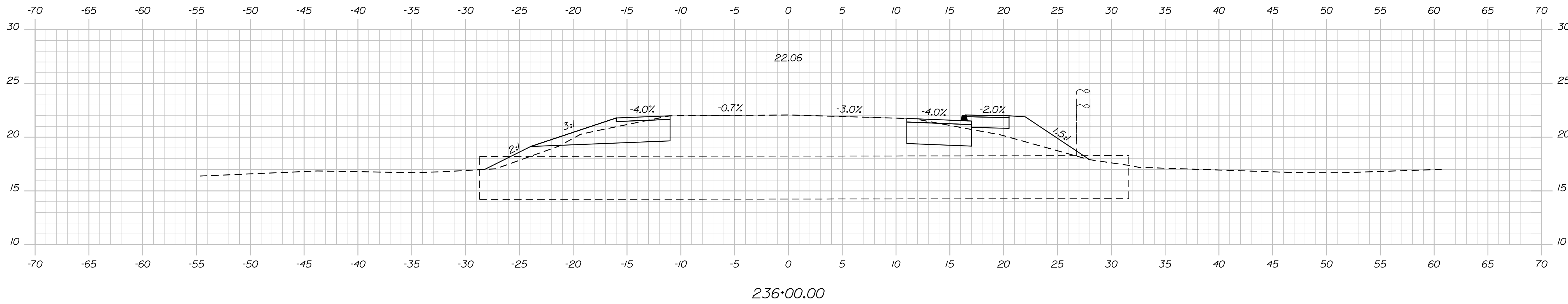
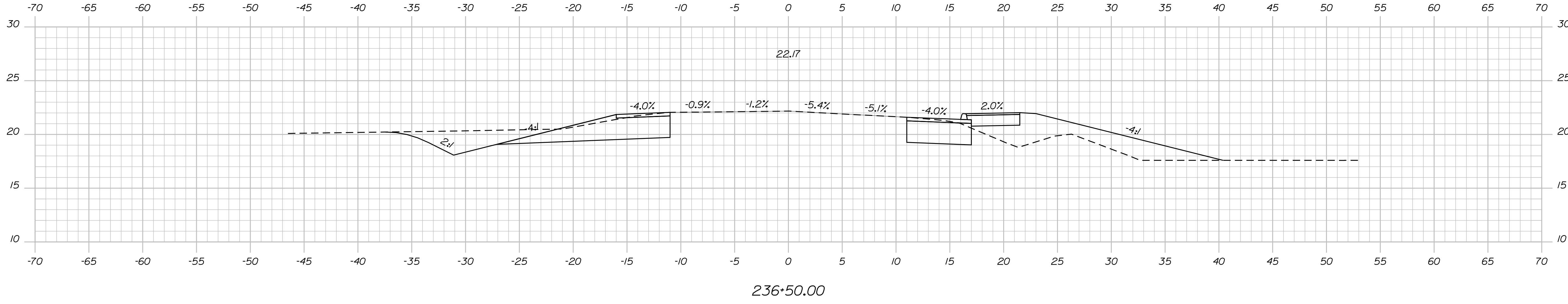

WORKING CROSS SECTIONS -
MODEL HAS NOT BEEN FULLY
DEVELOPED

STATE OF MAINE
DEPARTMENT OF TRANSPORTATION

SIGNATURE
P.E. NUMBER
DATE

| PROJ. MANAGER | BY | DATE |
|------------------|-----------|---------|
| J. BRUBAKER | T. WOLFEL | 06/2023 |
| CHECKED-REVIEWED | CHL | |
| DESIGN-REVIEWED | LEM | |
| DESIGN-DETAILED | | |
| REVISIONS 1 | | |
| REVISIONS 2 | | |
| REVISIONS 3 | | |
| REVISIONS 4 | | |
| FIELD CHANGES | | |

ELIOT ROUTE 103 YORK COUNTY
CROSS SECTIONS

SHEET NUMBER

OF SHEET

OF 22

Sta. 235+50.00 to Sta. 236+50.00

Date: 7/21/2023

Username: twolfel

Division: HIGHWAY

Filename: ... \00\HIGHWAY\MSTA\sect.dgn

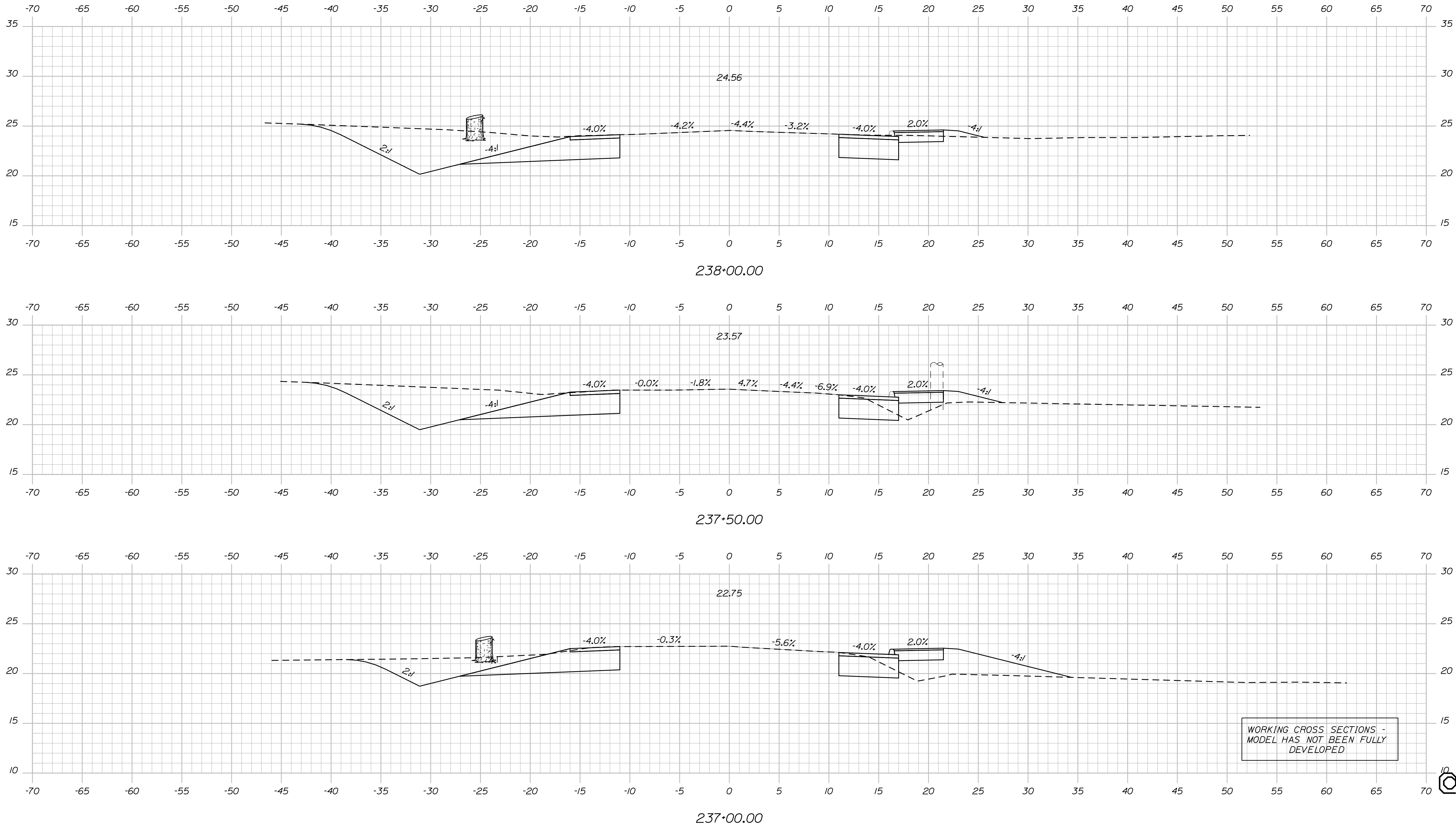

STATE OF MAINE
DEPARTMENT OF TRANSPORTATION

ELIOT
ROUTE 103 YORK COUNTY

CROSS SECTIONS

PROJ. MANAGER: J. BRUBAKER
DESIGN: T. WOLFEL
CHECKED: L. WOLFEL
DESIGNED: L. WOLFEL
REVISIONS: 1, 2, 3, 4
FIELD CHANGES

SHEET NUMBER
OF 22

HIGHWAY PLANS

DATE: 06/20/23
SIGNATURE:
P.E. NUMBER:
DATE:

WORKING CROSS SECTIONS -
MODEL HAS NOT BEEN FULLY
DEVELOPED

OS SHEET

Date: 7/21/2023

Username: twolfel

Division: HIGHWAY

Filename: ... \00\HIGHWAY\MSTA\sect.dgn

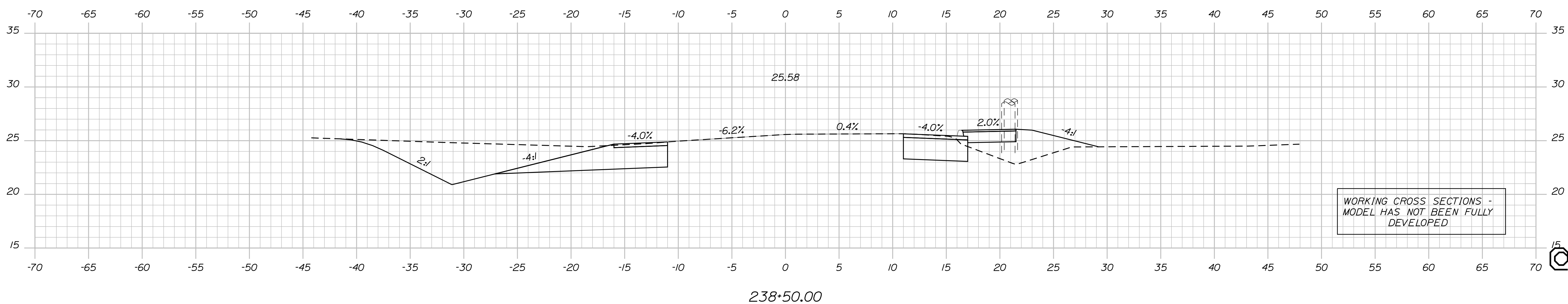
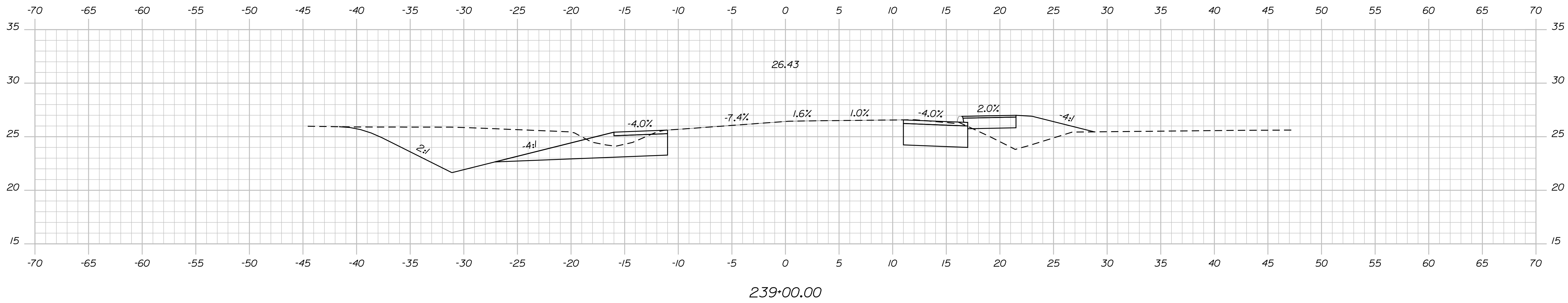
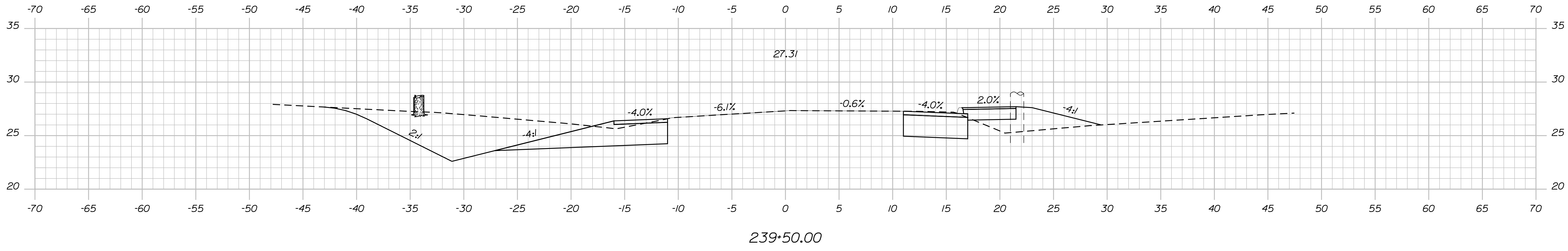

WORKING CROSS SECTIONS -
MODEL HAS NOT BEEN FULLY
DEVELOPED

STATE OF MAINE
DEPARTMENT OF TRANSPORTATION

SIGNATURE
P.E. NUMBER
DATE

| PROJ. MANAGER | BY | DATE |
|------------------|-----------|---------|
| J. BRUBAKER | T. WOLFEL | 06/2023 |
| CHECKED-REVIEWED | CHL | |
| DESIGN-REVIEWED | LEM | |
| DESIGN-REVIEWED | L. MEEK | |
| DESIGN-REVIEWED | | |
| REVISIONS 1 | | |
| REVISIONS 2 | | |
| REVISIONS 3 | | |
| REVISIONS 4 | | |
| FIELD CHANGES | | |

ELIOT ROUTE 10 YORK COUNTY
CROSS SECTIONS

SHEET NUMBER

OF SHEET

OF 22

Date: 7/21/2023

Username: twolfel

Division: HIGHWAY

Filename: ... \00\HIGHWAY\MSTA\sect.dgn

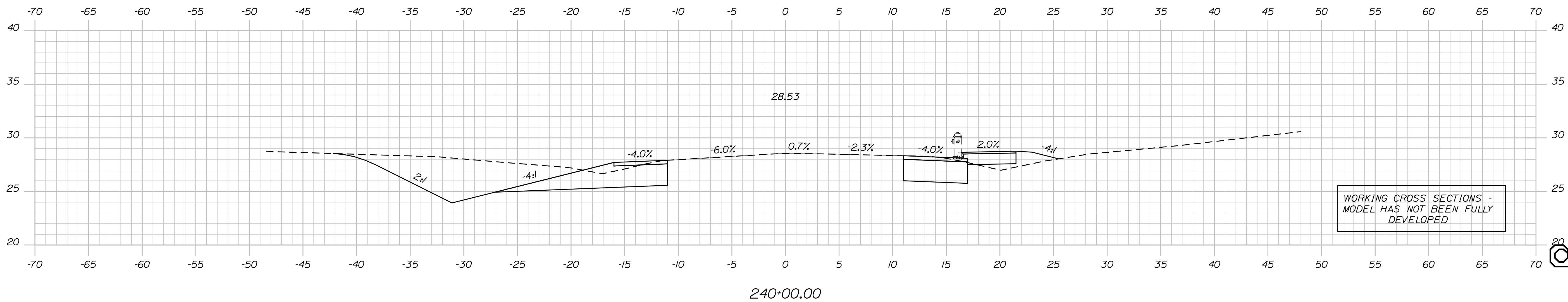
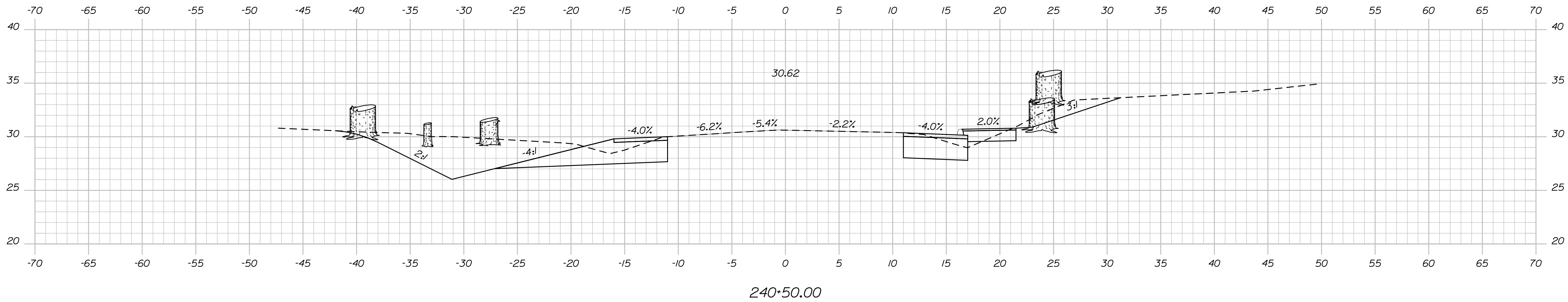
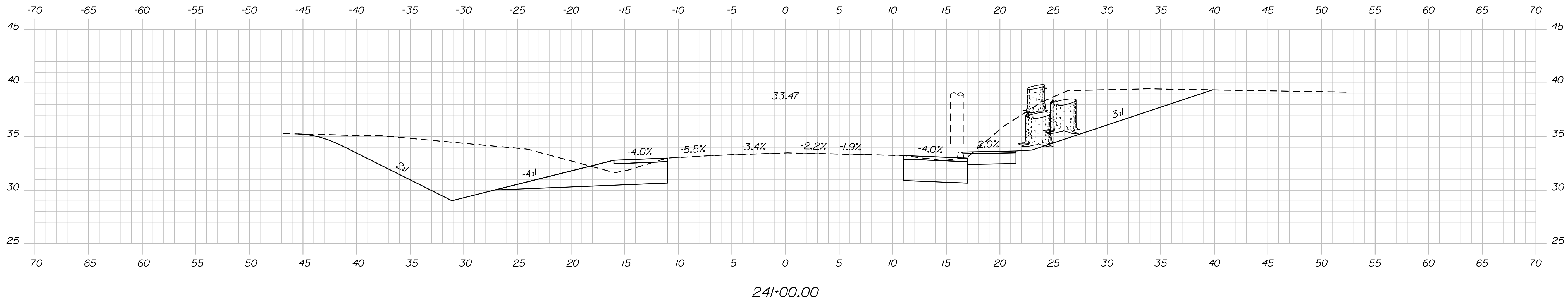

WORKING CROSS SECTIONS -
MODEL HAS NOT BEEN FULLY
DEVELOPED

STATE OF MAINE
DEPARTMENT OF TRANSPORTATION

ELIOT
ROUTE 103 YORK COUNTY

CROSS SECTIONS

SHEET NUMBER

OF 22

HIGHWAY PLANS

SIGNATURE

DATE

PROJ. MANAGER
DESIGN-DETAILED
CHECKED-REVIEWED
DESIGN-DETAILED
REVISIONS 1
REVISIONS 2
REVISIONS 3
REVISIONS 4
FIELD CHANGES

BY
DATE

J. BRUBAKER
T. WOLFEL
L. MEEK
L. MEEK

06/2023

DATE

P.E. NUMBER

DATE

Date: 7/21/2023

Username: twolfel

Division: HIGHWAY

Filename: ... \00\HIGHWAY\MSTA\sect.dgn

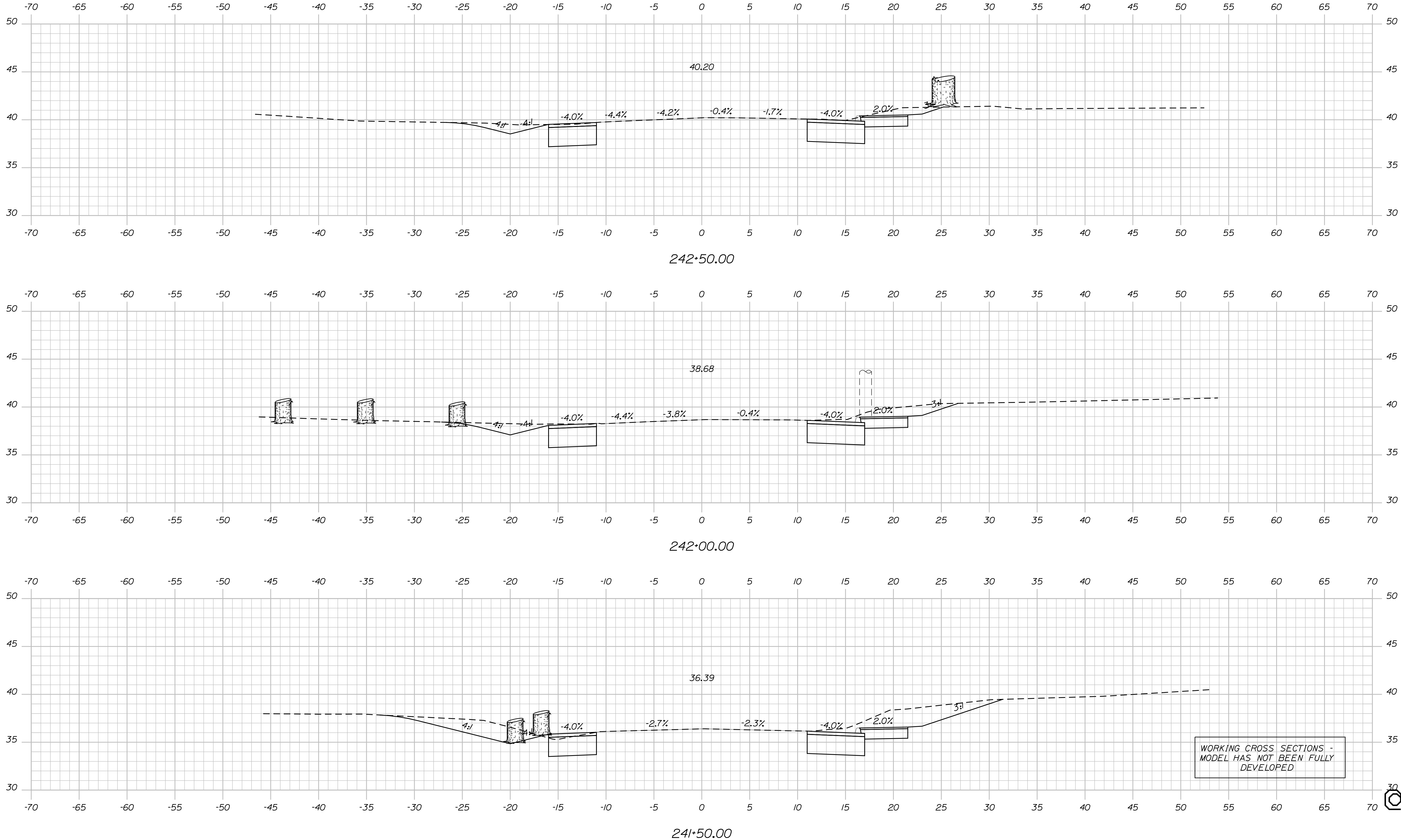

WORKING CROSS SECTIONS -
 MODEL HAS NOT BEEN FULLY
 DEVELOPED

STATE OF MAINE
 DEPARTMENT OF TRANSPORTATION

ELIOT
 ROUTE 103 YORK COUNTY

| PROJ. MANAGER | BY | DATE |
|---------------|-----------|---------|
| J. BRUBAKER | T. WOLFEL | 06/2023 |

CROSS SECTIONS

SHEET NUMBER

OF SHEET

OF 22

Sta. 241+50.00 to Sta. 242+50.00

Date: 7/21/2023

Username: twolfel

Division: HIGHWAY

Filename: ... \100\HIGHWAY\MSTA\sect.dgn

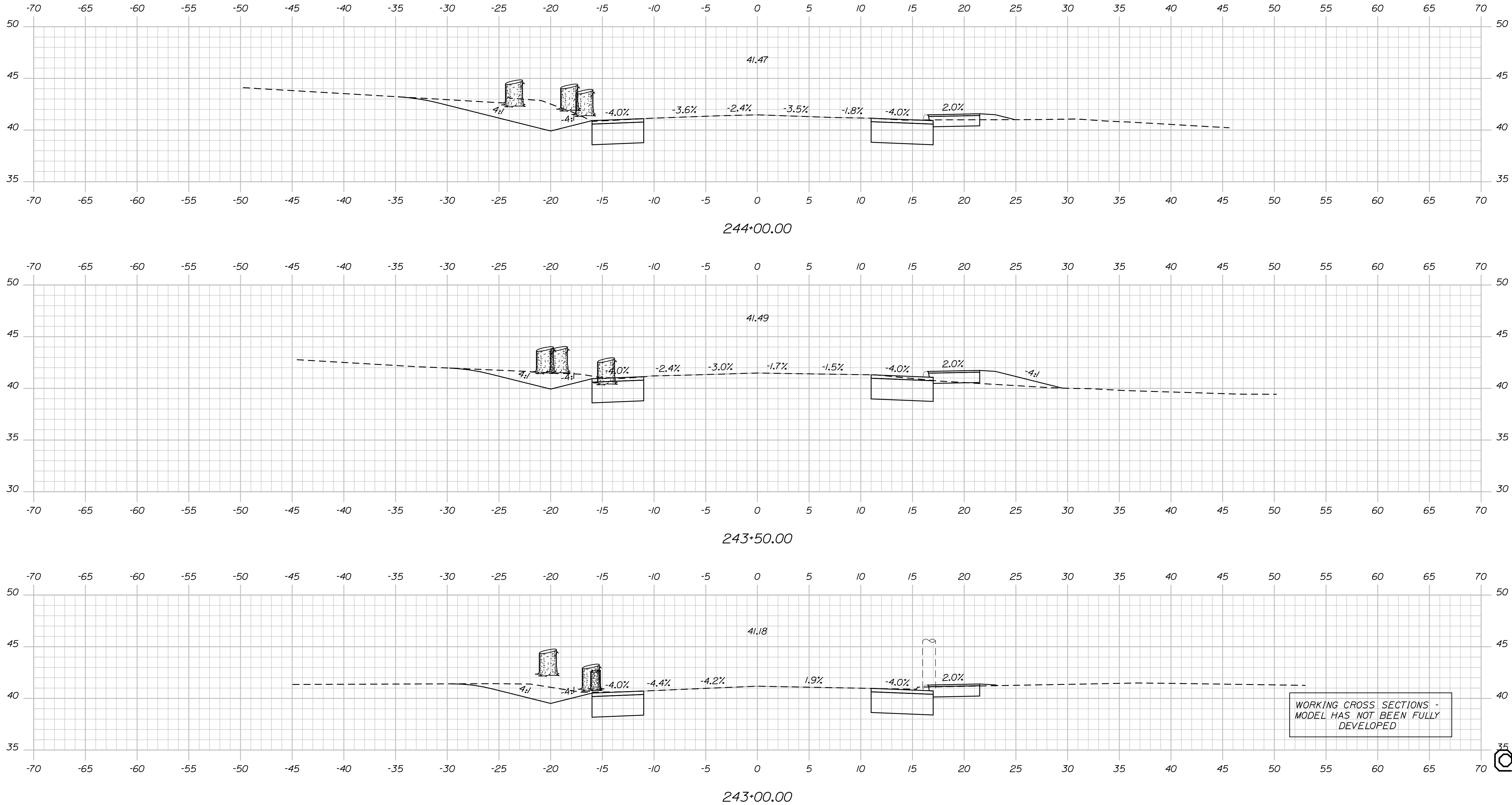

STATE OF MAINE
DEPARTMENT OF TRANSPORTATION

HIGHWAY PLANS

SIGNATURE

P.E. NUMBER

DATE

DATE

BY

DATE

PROJ. MANAGER

DESIGN DETAILED

CHECKED/REVIEWED

DESIGN DETAILED

REVISIONS 1

REVISIONS 2

REVISIONS 3

REVISIONS 4

FIELD CHANGES

ELIOT ROUTE 103 YORK COUNTY

CROSS SECTIONS

SHEET NUMBER

OF SHEET

OF 22

Sta. 243+00.00 to Sta. 244+00.00

Date: 7/21/2023

Username: twolfel

Division: HIGHWAY

Filename: ... \00\HIGHWAY\MSTA\sect.dgn

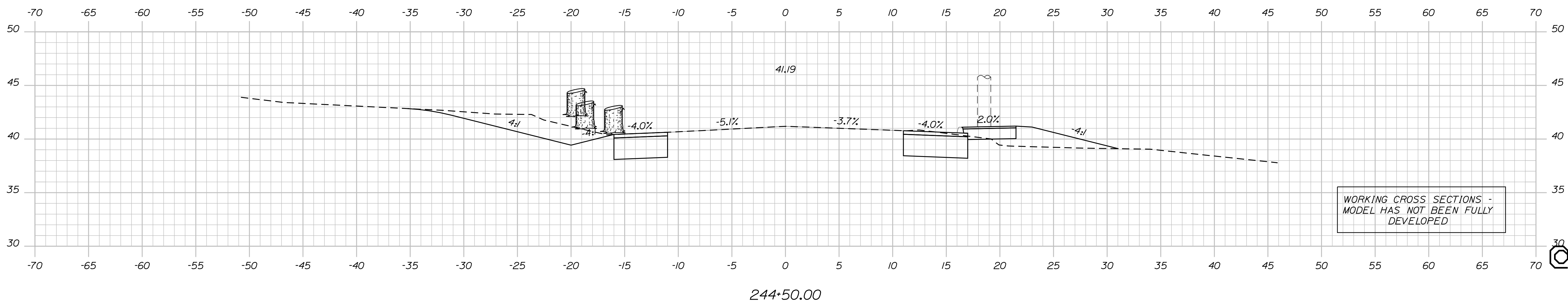
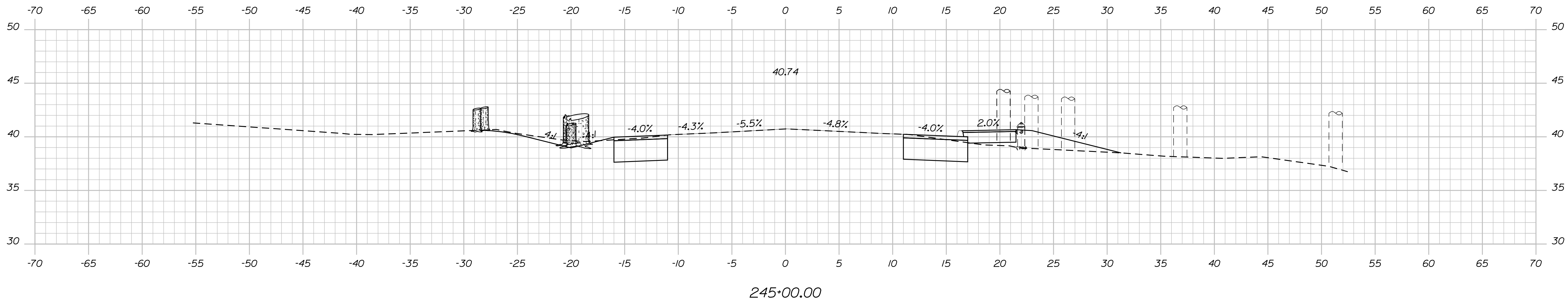
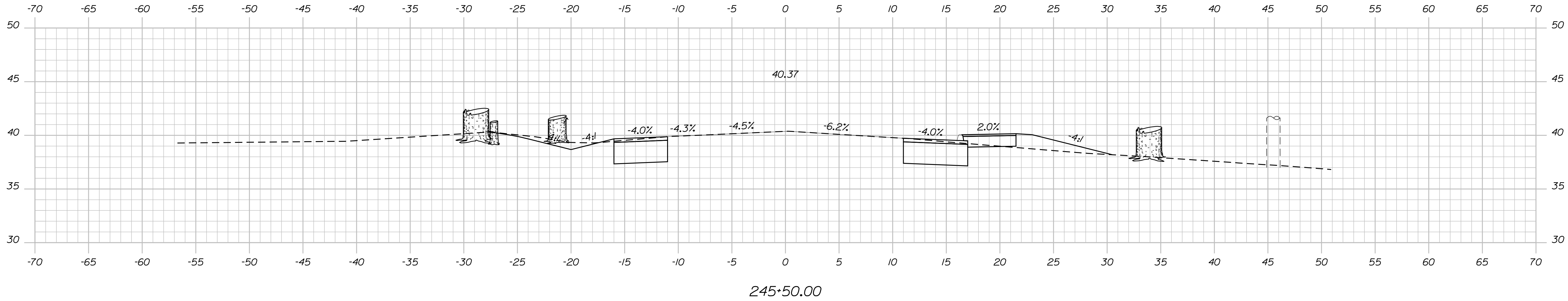

WORKING CROSS SECTIONS -
MODEL HAS NOT BEEN FULLY
DEVELOPED

STATE OF MAINE

DEPARTMENT OF TRANSPORTATION

HIGHWAY PLANS

DATE

06/2023

SIGNATURE

P.E. NUMBER

DATE

DATE

06/2023

BY

T. WOLFEL

PROJ. MANAGER

J. BRUBAKER

CHECKED

L. WEEK

DESIGNED

L. WEEK

REVISIONS 1

REVISIONS 2

REVISIONS 3

REVISIONS 4

FIELD CHANGES

ELIOT ROUTE 10 YORK COUNTY

CROSS SECTIONS

SHEET NUMBER

OF SHEET

OF 22

Sta. 244+50.00 to Sta. 245+50.00

Date: 7/21/2023

Username: twolfel

Division: HIGHWAY

Filename: ... \00\HIGHWAY\MSTA\sect.dgn

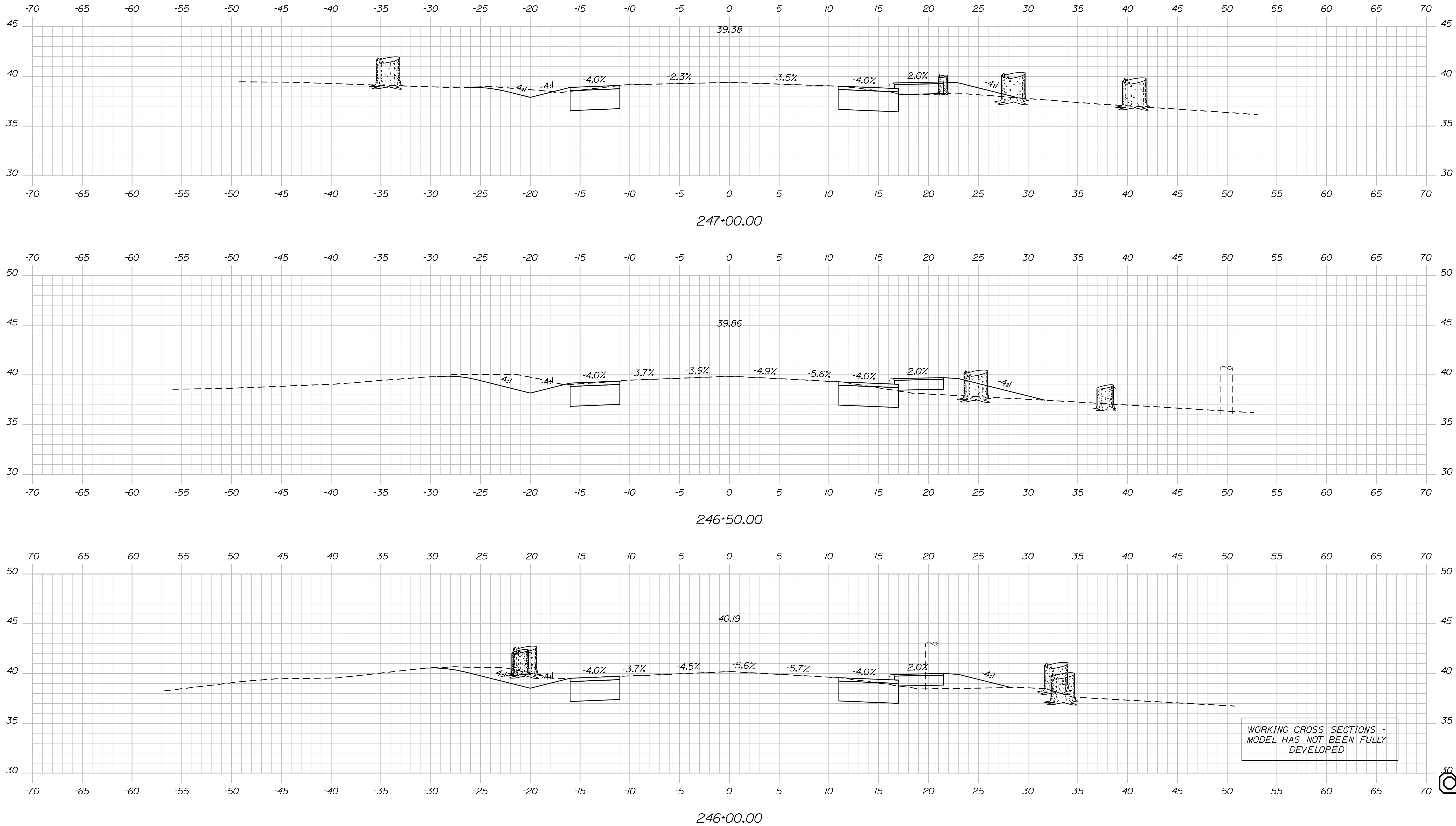

WORKING CROSS SECTIONS -
MODEL HAS NOT BEEN FULLY
DEVELOPED

STATE OF MAINE
DEPARTMENT OF TRANSPORTATION
HIGHWAY PLANS

PROJ. MANAGER: J. BRUBAKER
DESIGN-DETAILED: T. WOLFEL
CHECKED-REVIEWED: L. MEEK
DESIGN-DETAILED: L. MEEK
REVISIONS 1:
REVISIONS 2:
REVISIONS 3:
REVISIONS 4:
FIELD CHANGES:

DATE: 06/20/2023
SIGNATURE:
P.E. NUMBER:
DATE:

ELIOT ROUTE 10 YORK COUNTY
CROSS SECTIONS

SHEET NUMBER

OS SHEET

OF 22

Sta. 246+00.00 to Sta. 247+00.00

Date: 7/21/2023

Username: twolfel

Division: HIGHWAY

Filename: ... \00\HIGHWAY\MSTA\sect.dgn

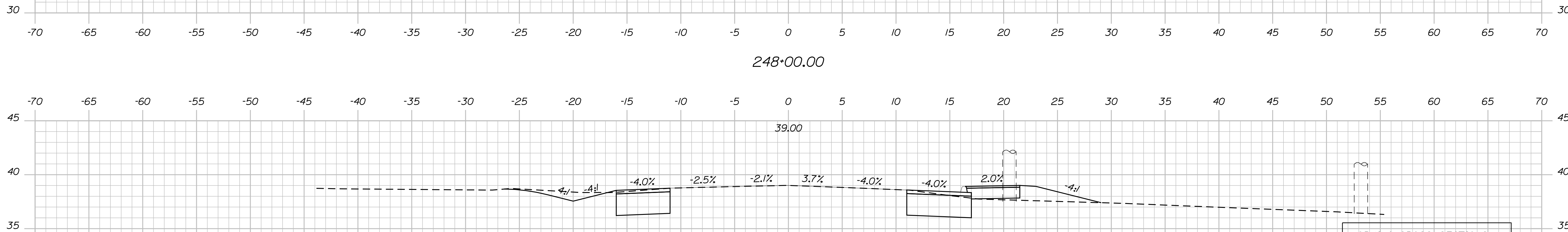
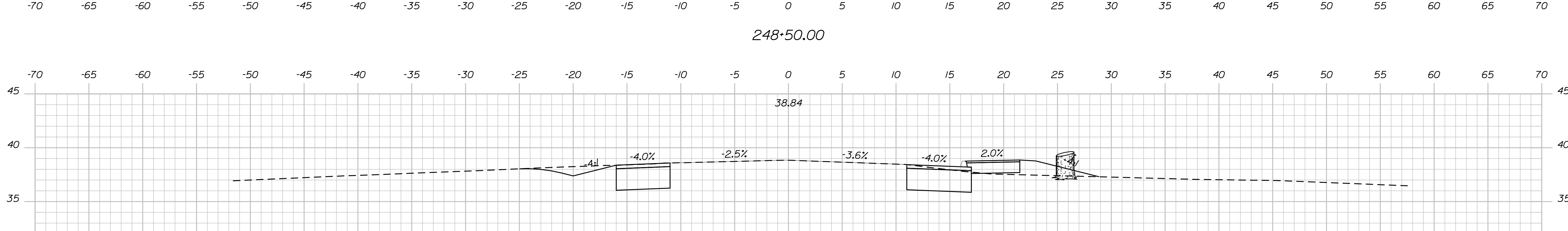
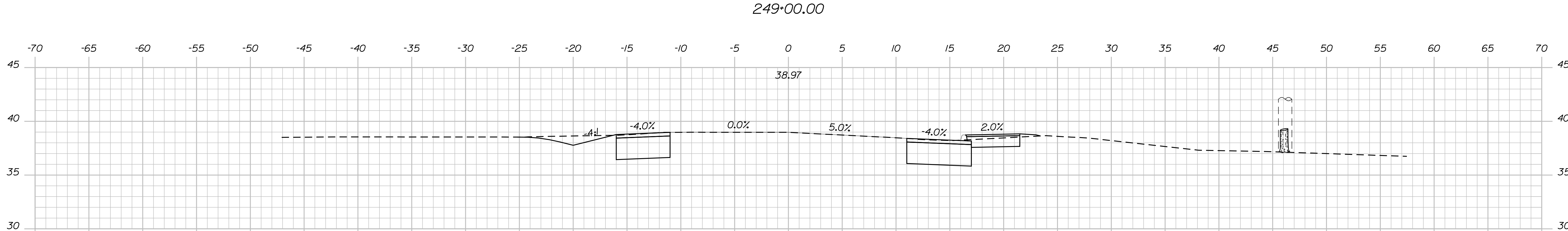
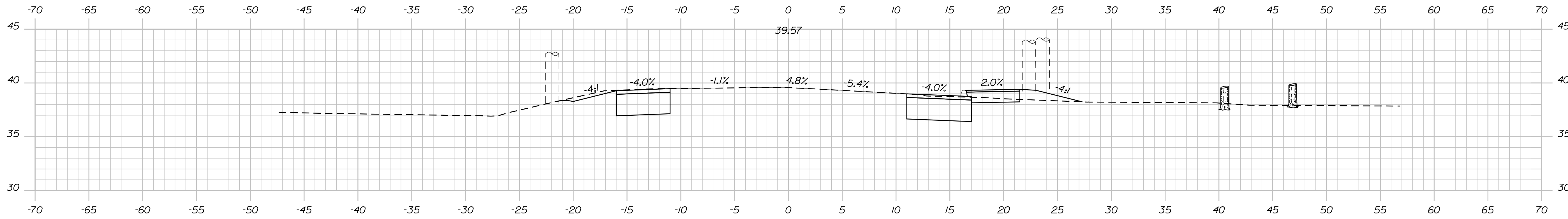

WORKING CROSS SECTIONS -
MODEL HAS NOT BEEN FULLY
DEVELOPED

STATE OF MAINE
DEPARTMENT OF TRANSPORTATION

ELIOT ROUTE 10 YORK COUNTY

| PROJ. MANAGER | BY | DATE |
|------------------|-----------|-------------|
| J. BRUBAKER | T. WOLFEL | 06/2023 |
| CHECKED-REVIEWED | CHL | SIGNATURE |
| DESIGN-DETAILED | LEM | P.E. NUMBER |
| DESIGN-DETAILED | | DATE |
| REVISIONS 1 | | |
| REVISIONS 2 | | |
| REVISIONS 3 | | |
| REVISIONS 4 | | |
| FIELD CHANGES | | |

CROSS SECTIONS

SHEET NUMBER

OS SHEET

Date: 7/21/2023

Username: twolfel

Division: HIGHWAY

Filename: ... \00\HIGHWAY\MSTA\sect.dgn

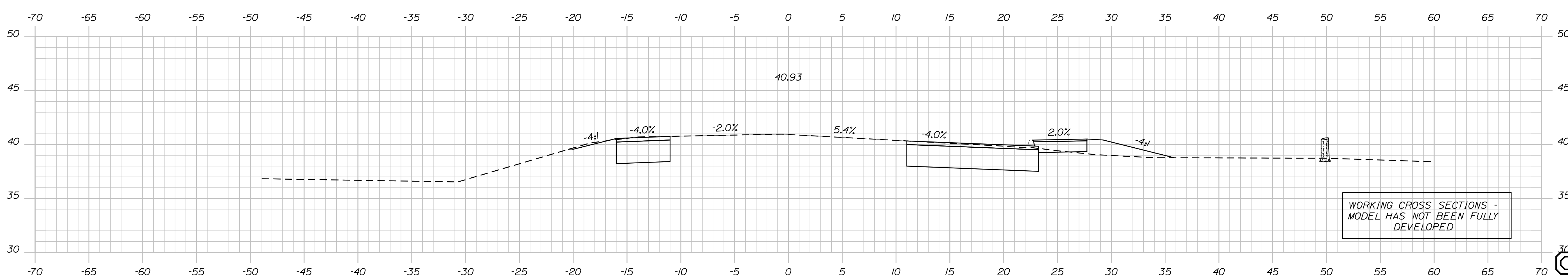
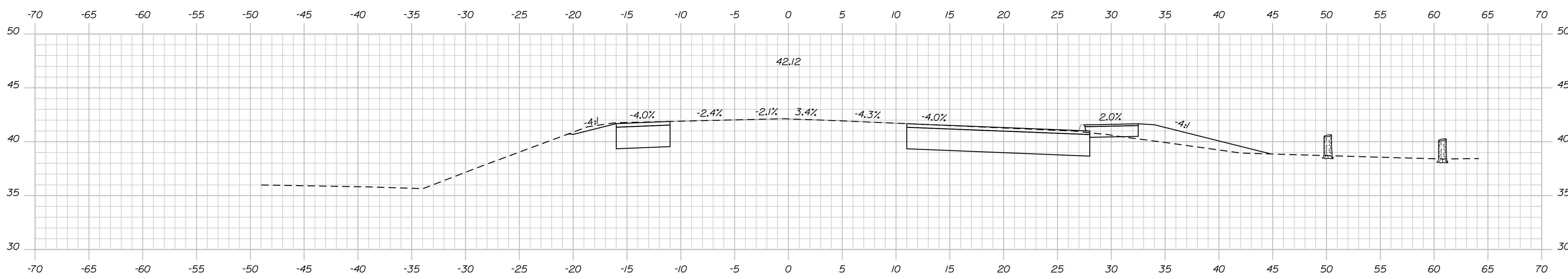
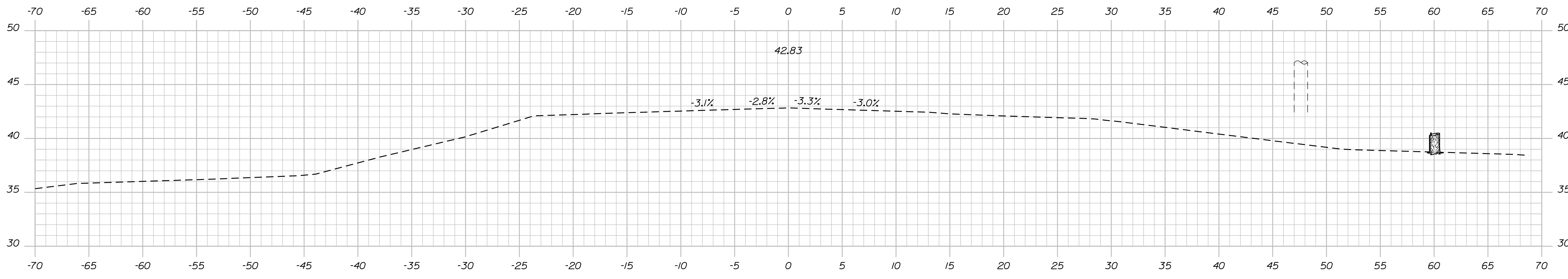

WORKING CROSS SECTIONS -
MODEL HAS NOT BEEN FULLY
DEVELOPED

STATE OF MAINE
DEPARTMENT OF TRANSPORTATION

ELIOT ROUTE 103 YORK COUNTY

| PROJ. MANAGER | BY | DATE |
|------------------|-----------|----------|
| J. BRUBAKER | T. WOLFEL | 06/20/23 |
| CHECKED-REVIEWED | CHL | |
| DESIGN-REVIEWED | LEM | |
| DESIGN-REVIEWED | L. MEEK | |
| DESIGN-REVIEWED | | |
| REVISIONS 1 | | |
| REVISIONS 2 | | |
| REVISIONS 3 | | |
| REVISIONS 4 | | |
| FIELD CHANGES | | |

CROSS SECTIONS

SHEET NUMBER

OF SHEET

OF 22