

PLAN LEGEND

Town, County, State	-----	Catch Basins	▣ Existing	■ Proposed
Property Lines	-----	Manholes	○ Existing	● Proposed
R/W Lines-Existing	-----	Proposed Underdrain	-----	
R/W Lines-Proposed	-----	Proposed Ditch	-----	
Culvert-Existing	-----	Existing Ditch	-----	
Culvert Proposed	-----	Utility Poles	⊕ Existing	◆ Proposed
Curbing	Existing Proposed	Fire Hydrants	⊕ Existing	⊕ Proposed
Type 1	-----	Existing Water Line	-----	
Type 3	-----	Existing San. Sewer	-----	
Type 5	-----	Existing San. Sewer Manhole	⊙	
Outline of Bodies of Water	-----	Guardrail-Existing	-----	
Exposed Bedrock	-----	Guardrail-Proposed	-----	
Buildings	-----	Guardrail-Cable, Other	-----	
Trees	Conifer Deciduous	Centerline-Existing	-----	
Tree Line	-----	Centerline-Proposed	-----	
Clearing Limit Line	-----	Travelway-Existing	-----	
Railroad	-----	Travelway-Proposed	-----	
Boring	HB-XXX-###	Probe	P-#. #X	
Pavement Core	● PC-#		#.# = Depth	
Test Pit	TP-XXX-###		X = W (Weathered Rock)	
			R (Refusal)	
			NR (No Refusal)	

TOWN OF ELIOT

ELIOT

YORK COUNTY

**STATE & BEECH ROAD
PROJECT LENGTH: 2.40 MILES
RECONSTRUCTION**

INDEX OF SHEETS

Description	Sheet No.
Title Sheet	1
Typical Sections	2
Plan Sheets	3-22

**FINAL 10% PLANS
JULY 21, 2023**

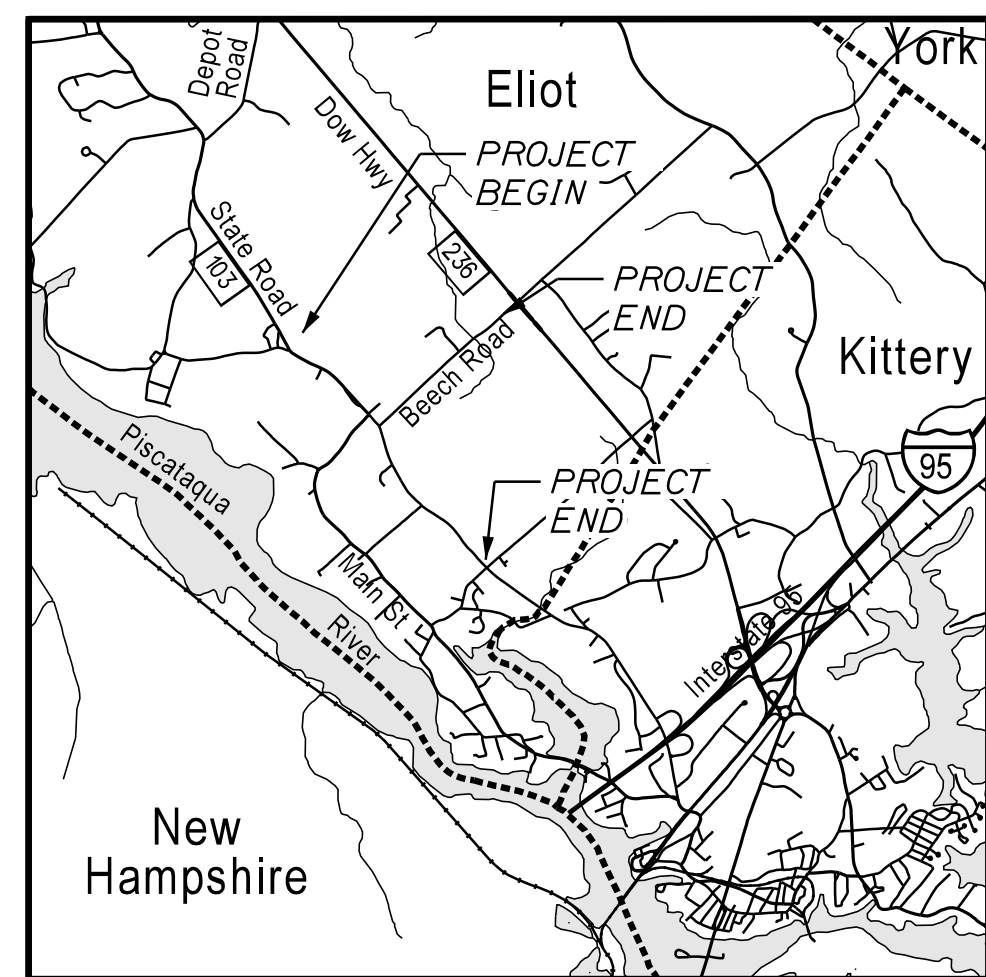

LOCATION MAP

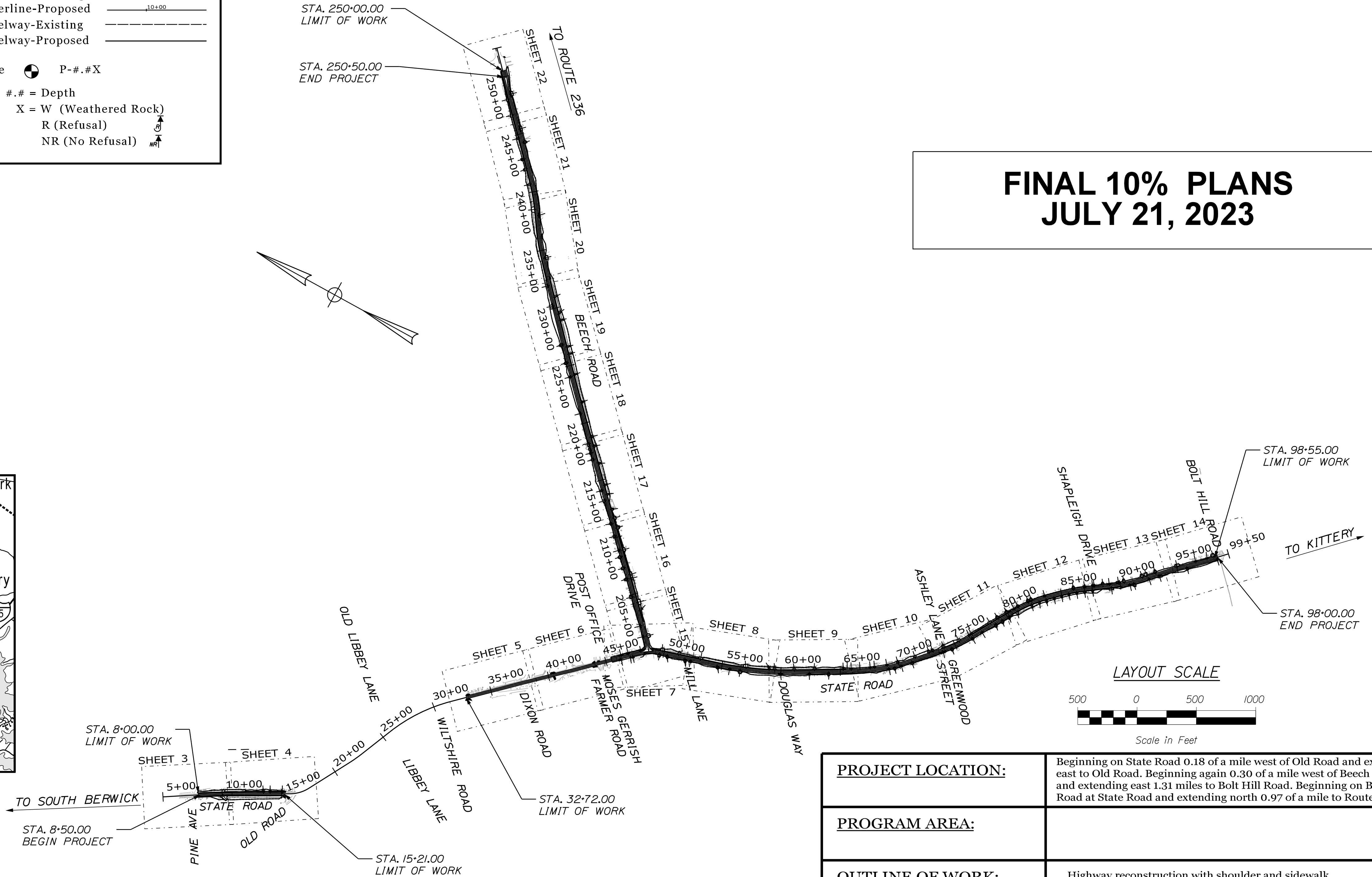
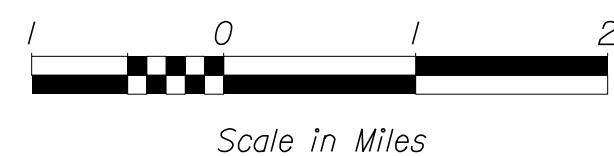

LAYOUT SCALE

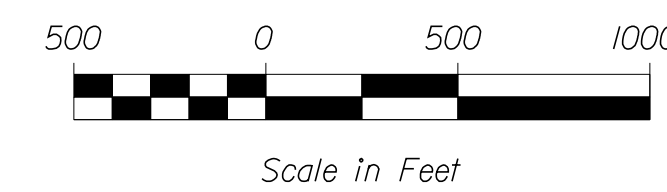

PROJECT LOCATION:	Beginning on State Road 0.18 of a mile west of Old Road and extending east to Old Road. Beginning again 0.30 of a mile west of Beech Road and extending east 1.31 miles to Bolt Hill Road. Beginning on Beech Road at State Road and extending north 0.97 of a mile to Route 236.
PROGRAM AREA:	
OUTLINE OF WORK:	Highway reconstruction with shoulder and sidewalk improvements.

TOWN OF ELIOT

PROJECT INFORMATION	
PROGRAM	HIGHWAY PROGRAM
PROJECT MANAGER	JEFF BRUBAKER
DESIGNER	LAUREN WEEK
CONSULTANT	STANTEC
PROJECT RESIDENT	
CONTRACTOR	
PROJECT COMPLETION DATE	
SIGNATURE	
P.E. NUMBER	
DATE	

**ELIOT
STATE & BEECH ROAD
TITLE SHEET**

SHEET NUMBER

1

OF 22

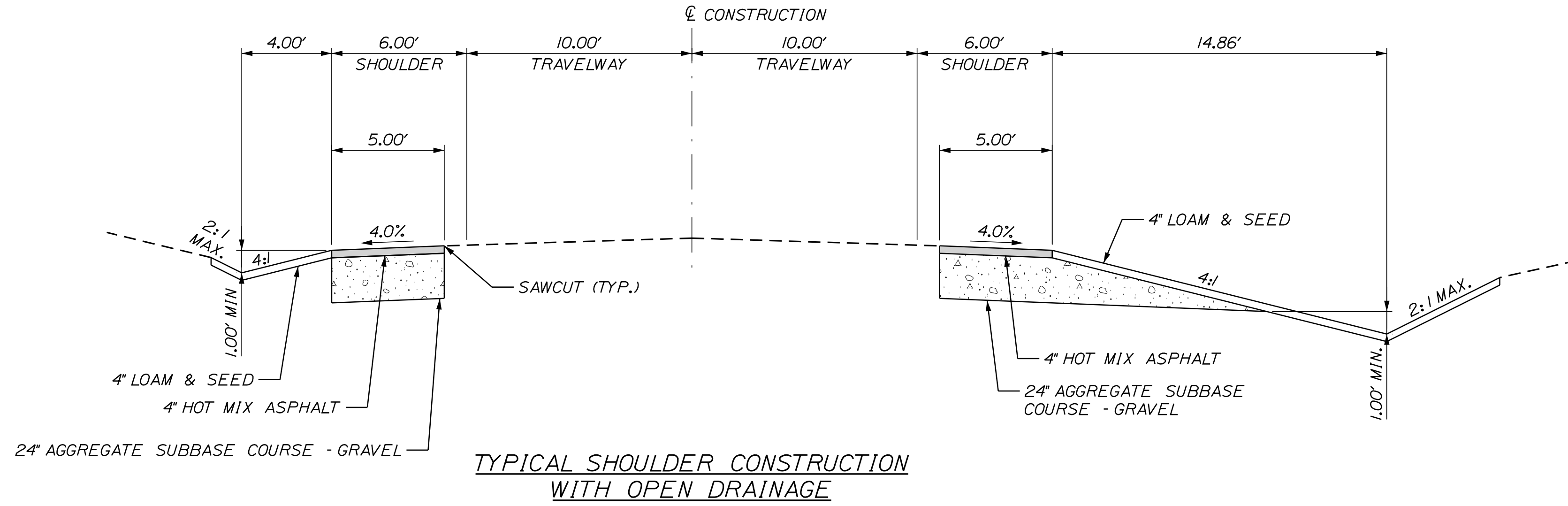
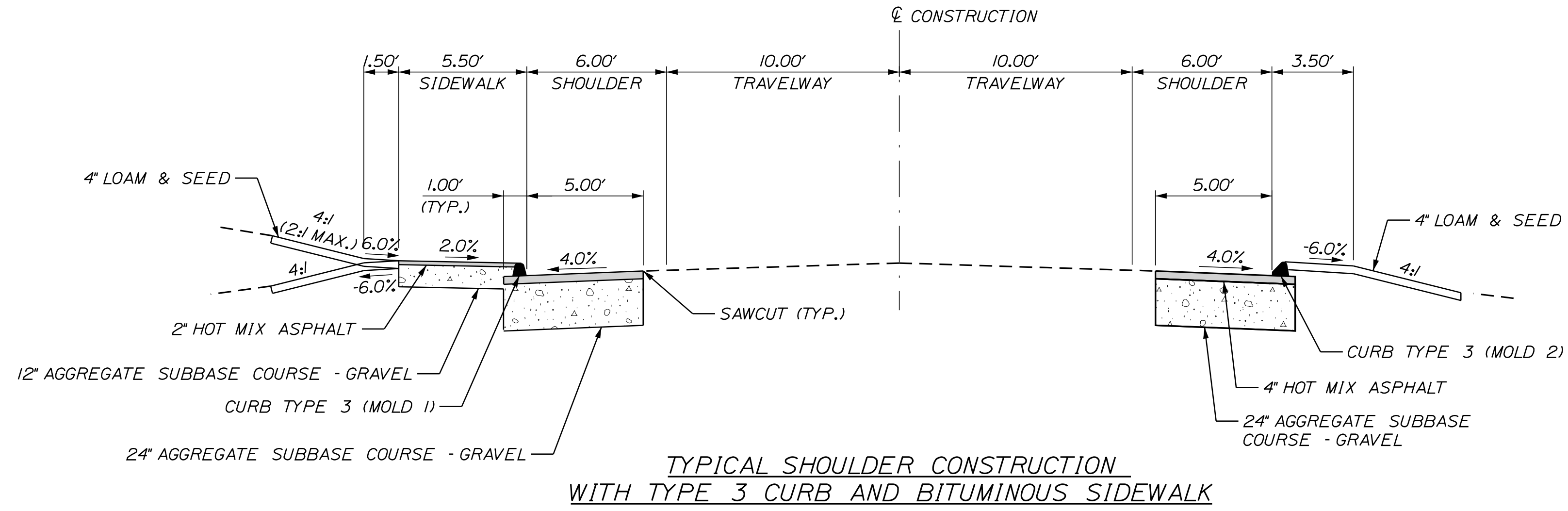

TOWN OF ELIOT

ELIOT
STATE & BEECH ROAD

TYPICAL SECTIONS

SHEET NUMBER

2

OF 22

PROJ. MANAGER	J. BRUBAKER	BY	DATE
DESIGN-DETAILED	T. WOLFEL	CHL	7/2023
CHECKED-REVIEWED	L. MEEK	LEM	7/2023
DESIGN-DETAILED			
REVISIONS 1			
REVISIONS 2			
REVISIONS 3			
REVISIONS 4			
FIELD CHANGES			

SIGNATURE	P.E. NUMBER	DATE

HIGHWAY PLANS

POB = STA. 5+00.00

5+00

S32°22'14.54"E

6+00

7+00

8+00

9+00

10+00

PC = STA. 6+49.81

JOHN W. WALLPE
JANICE W. WALLPE

REGINALD F. DUNLAP
ELEANOR J. DUNLAP

WILLIAM FOGG LIBRARY TRUST

NEIL R. KAVANAUGH
MICHELE J. KAVANAUGH

JOHN F. HILL
GRANGE HALL

NOTE:
GRANGE HALL ENTRANCE DESIGN TO BE
COORDINATED WITH ELIOT GRANGE (PROPERTY
OWNER), ELIOT HISTORICAL SOCIETY, AND
GREAT WORKS REGIONAL LAND TRUST.

REMOVE

REMOVE

REMOVE

REMOVE

REMOVE

REMOVE

SAWCUT
(TYP.)

EASEMENT TO
NEW ENGLAND TELEPHONE
& TELEGRAPH
BOOK 353, PAGE 350
DATED 11/01/83

PROPOSED STRIPING

CURVE DATA #1
PI = 9+17.88
D = 0°39'17.3"
Δ = 3°30'34.7" Rt.
R = 8750.00'
L = 535.98'
T = 268.07'
E = 4.11'

TOWN OF ELIOT

ELIOT
STATE & BEECH ROAD

PLANS

SHEET NUMBER

3

OF 22

PROJ. MANAGER	J. BRUBAKER	BY	CHL	DATE	7/2023
DESIGN DETAILED	T. WOLFEL	CHECKED	LEM	DATE	7/2023
CHECKED-REVIEWED	L. WEEK	DESIGN DETAILED		SIGNATURE	
DESIGN DETAILED		DESIGN DETAILED		P.E. NUMBER	
REVISIONS 1		REVISIONS 1		DATE	
REVISIONS 2		REVISIONS 2			
REVISIONS 3		REVISIONS 3			
REVISIONS 4		REVISIONS 4			
FIELD CHANGES					

HIGHWAY PLANS

Date: 7/21/2023

Username: twolfel

Division: HIGHWAY

Filename: ... \HIGHWAY\MSTA_HDPlan_002.dgn

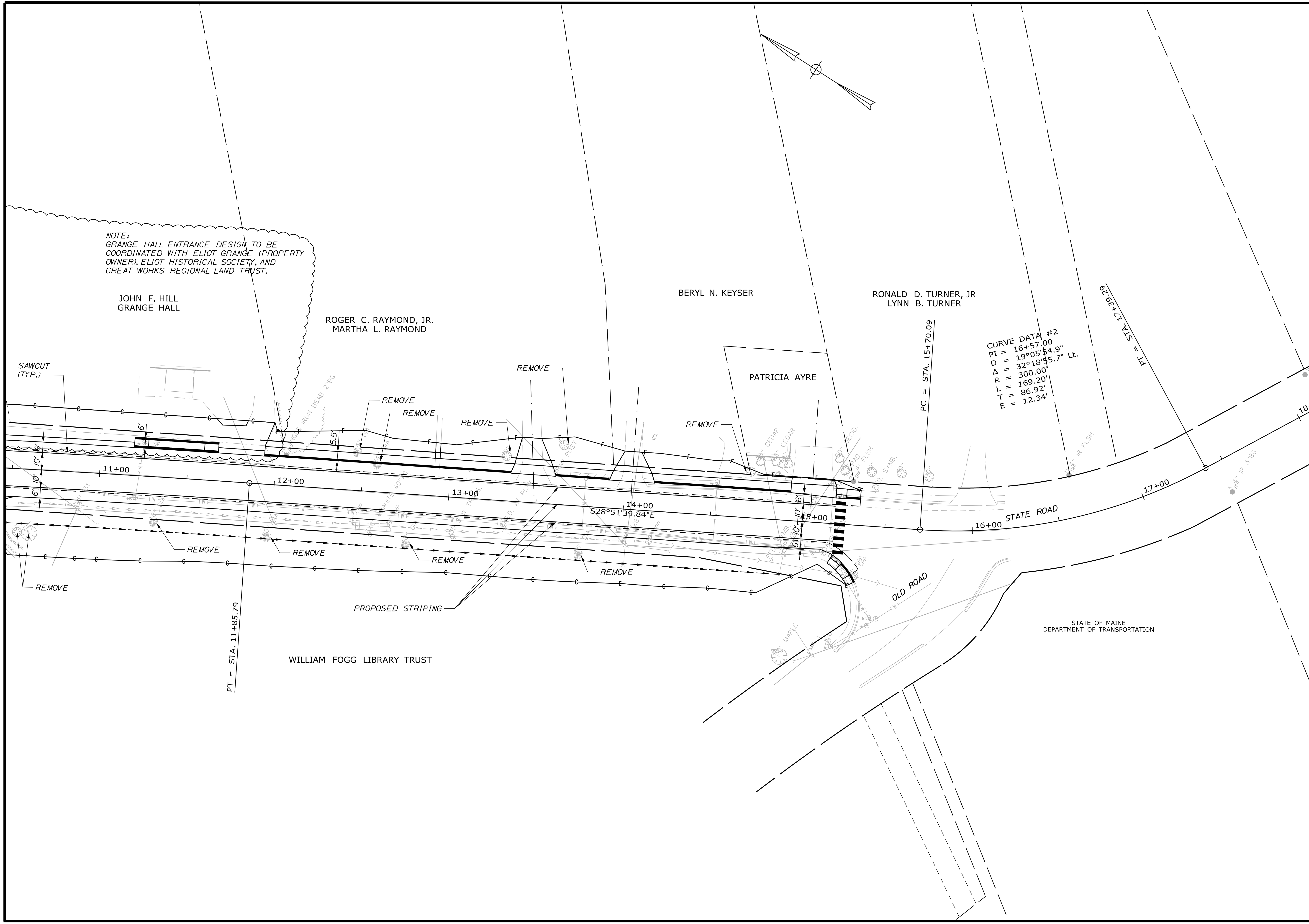

NOTE:
GRANGE HALL ENTRANCE DESIGN TO BE
COORDINATED WITH ELIOT GRANGE (PROPERTY
OWNER), ELIOT HISTORICAL SOCIETY, AND
GREAT WORKS REGIONAL LAND TRUST.

CURVE DATA #2
 PI = 16+57.00
 D = 19°05'54.9"
 Δ = 32°18'45.7" Lt.
 R = 300.00'
 L = 169.20'
 T = 86.92'
 E = 12.34'

STATE OF MAINE
DEPARTMENT OF TRANSPORTATION

TOWN OF ELIOT	
ELIOT STATE & BEECH ROAD	PLANS
SHEET NUMBER	4
OF 22	HIGHWAY PLANS

PROJ. MANAGER	J. BRUBAKER	BY	DATE
DESIGN DETAILED	T. WOLFEL	CHL	7/2023
CHECKED/REVIEWED	L. WEEK	LEM	7/2023
DESIGN DETAILED			
REVISIONS 1			
REVISIONS 2			
REVISIONS 3			
REVISIONS 4			
FIELD CHANGES			

DATE	SIGNATURE	P.E. NUMBER	DATE

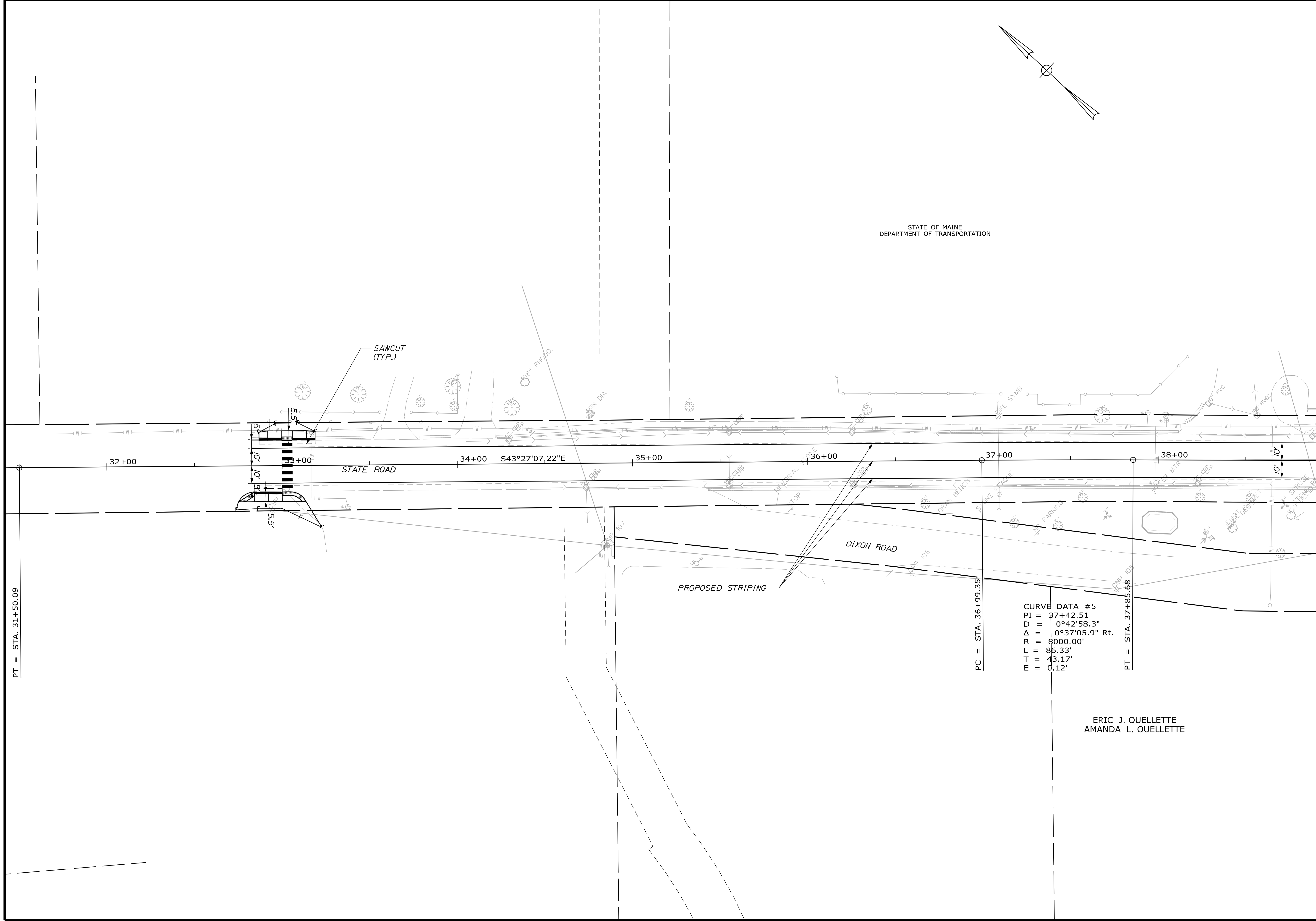

TOWN OF ELIOT

PROJ. MANAGER	J. BRUBAKER	BY	DATE
DESIGN DETAILED	T. WOLFEL	CHL	7/2023
CHECKED-REVIEWED	L. WEEK	LEM	7/2023
DESIGN DETAILED			
REVISIONS 1			
REVISIONS 2			
REVISIONS 3			
REVISIONS 4			
FIELD CHANGES			

SIGNATURE	P.E. NUMBER	DATE

ELIOT
STATE & BEECH ROAD
PLANS

SHEET NUMBER
5
OF 22

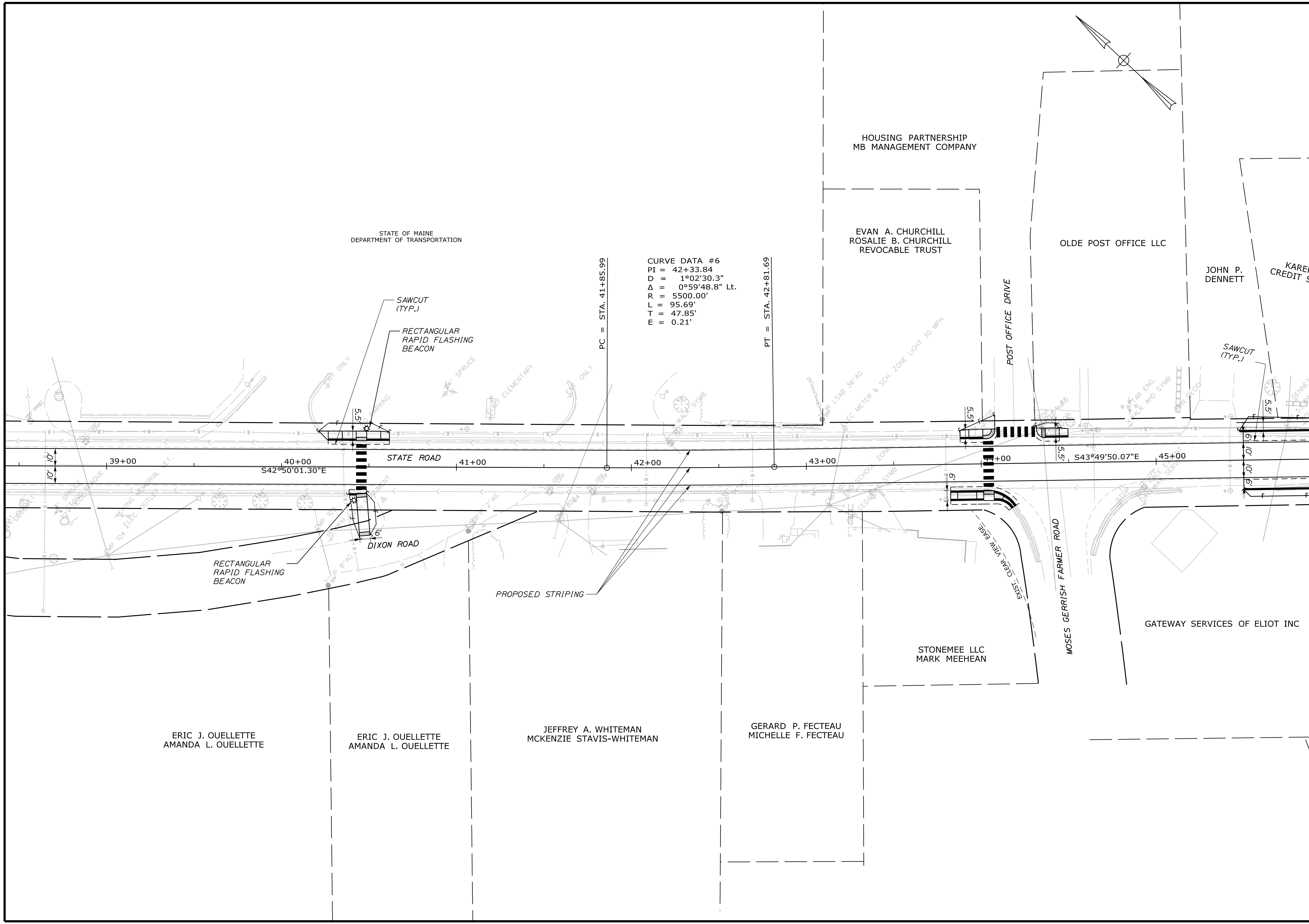

ELIOT STATE & BEECH ROAD PLANS

PROJ. MANAGER	J. BRUBAKER	BY	DATE
DESIGN DETAILED	T. WOLFEL	CHL	7/2023
CHECKED-REVIEWED	L. MEEK	LEM	7/2023
DESIGNS DETAILED			
REVISIONS 1			
REVISIONS 2			
REVISIONS 3			
REVISIONS 4			
FIELD CHANGES			

SIGNATURE	P.E. NUMBER	DATE

TOWN OF ELIOT

HIGHWAY PLANS

SHEET NUMBER

6

OF 22

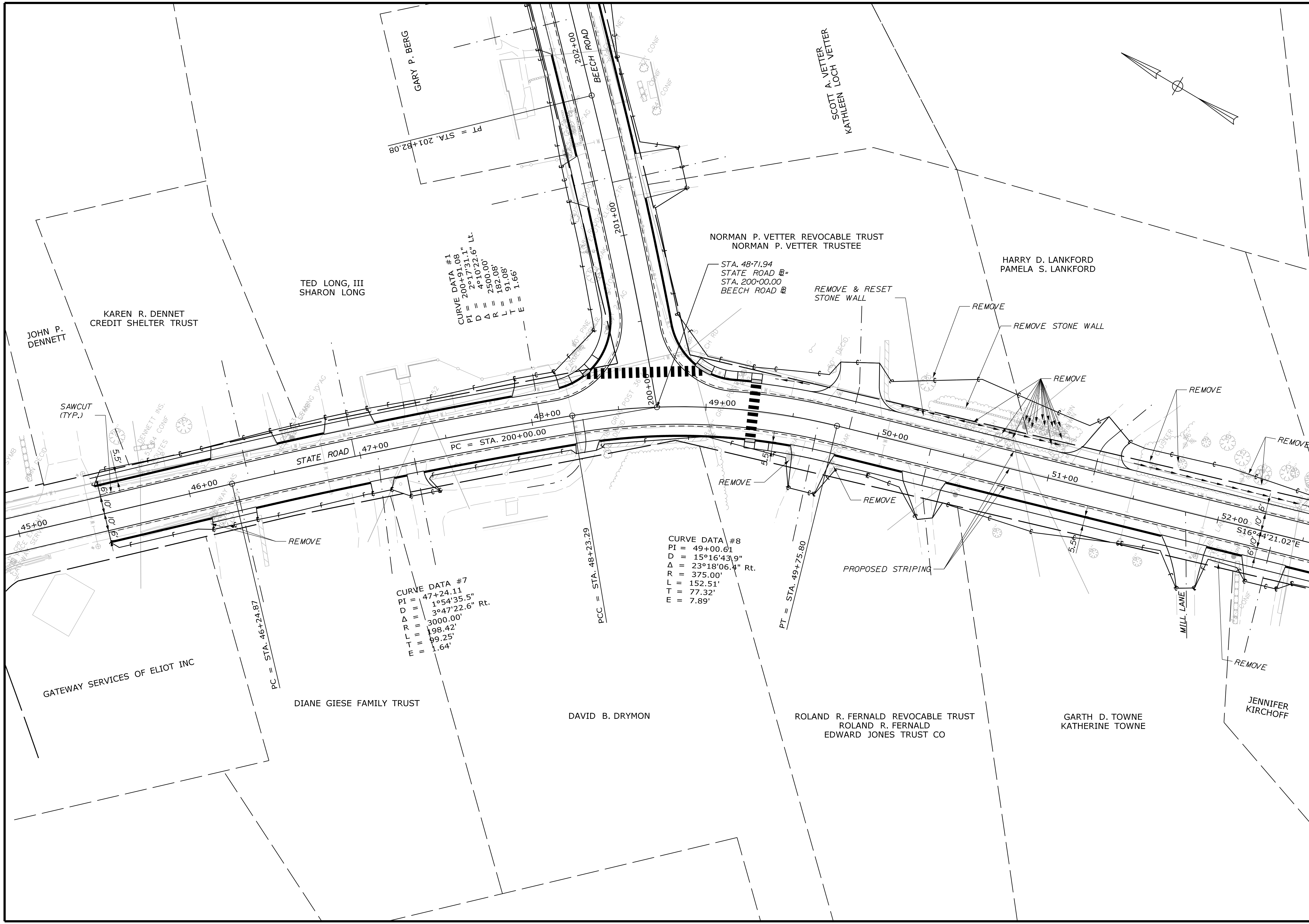

TOWN OF ELIOT		HIGHWAY PLANS	
DATE	7/2023	SIGNATURE	
BY	J. BRUBAKER	P.E. NUMBER	
DESIGN DETAILED	T. WOLFEL	DATE	
CHECKED/REVIEWED	L. WEEK		
DESIGN DETAILED			
REVISIONS 1			
REVISIONS 2			
REVISIONS 3			
REVISIONS 4			
FIELD CHANGES			
ELIOT STATE & BEECH ROAD		SHEET NUMBER	
PLANS		7	
		OF 22	

Date: 7/21/2023

Username: twolfel

Division: HIGHWAY

Filename: ... \HIGHWAY\MSTA_HDPlan_008.dgn

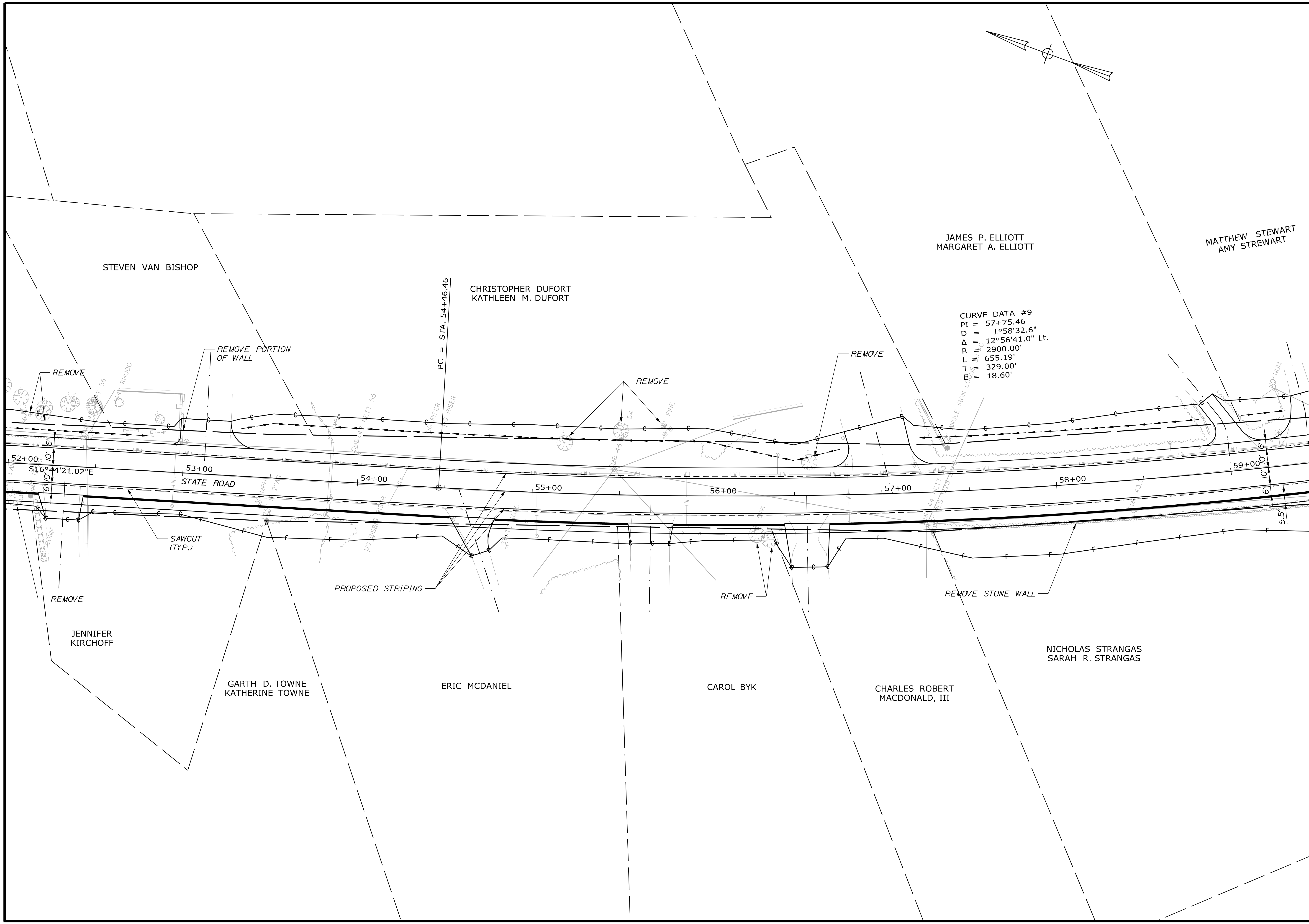

TOWN OF ELIOT	
	MATTHEW STEWART AMY STEWART
STEVEN VAN BISHOP	
CHRISTOPHER DUFORT KATHLEEN M. DUFORT	
JENNIFER KIRCHOFF	
GARTH D. TOWNE KATHERINE TOWNE	
ERIC MCDANIEL	
CAROL BYK	
CHARLES ROBERT MACDONALD, III	
NICHOLAS STRANGAS SARAH R. STRANGAS	
JAMES P. ELLIOTT MARGARET A. ELLIOTT	
STATE & BEECH ROAD	
PLANS	
SHEET NUMBER	
8	
OF 22	

PROJ. MANAGER	J. BRUBAKER	BY	DATE
DESIGN-DETAILED	T. WOLFEL	CHL	7/2023
CHECKED-REVIEWED	L. WEEK	LEM	7/2023
DESIGN-DETAILED			
DESIGN-DETAILED			
REVISIONS 1			
REVISIONS 2			
REVISIONS 3			
REVISIONS 4			
FIELD CHANGES			

SIGNATURE	P.E. NUMBER	DATE

HIGHWAY PLANS

Date: 7/21/2023

Username: twolfel

Division: HIGHWAY

Filename: ... \HIGHWAY\MSTA_HDPlan_010.dgn

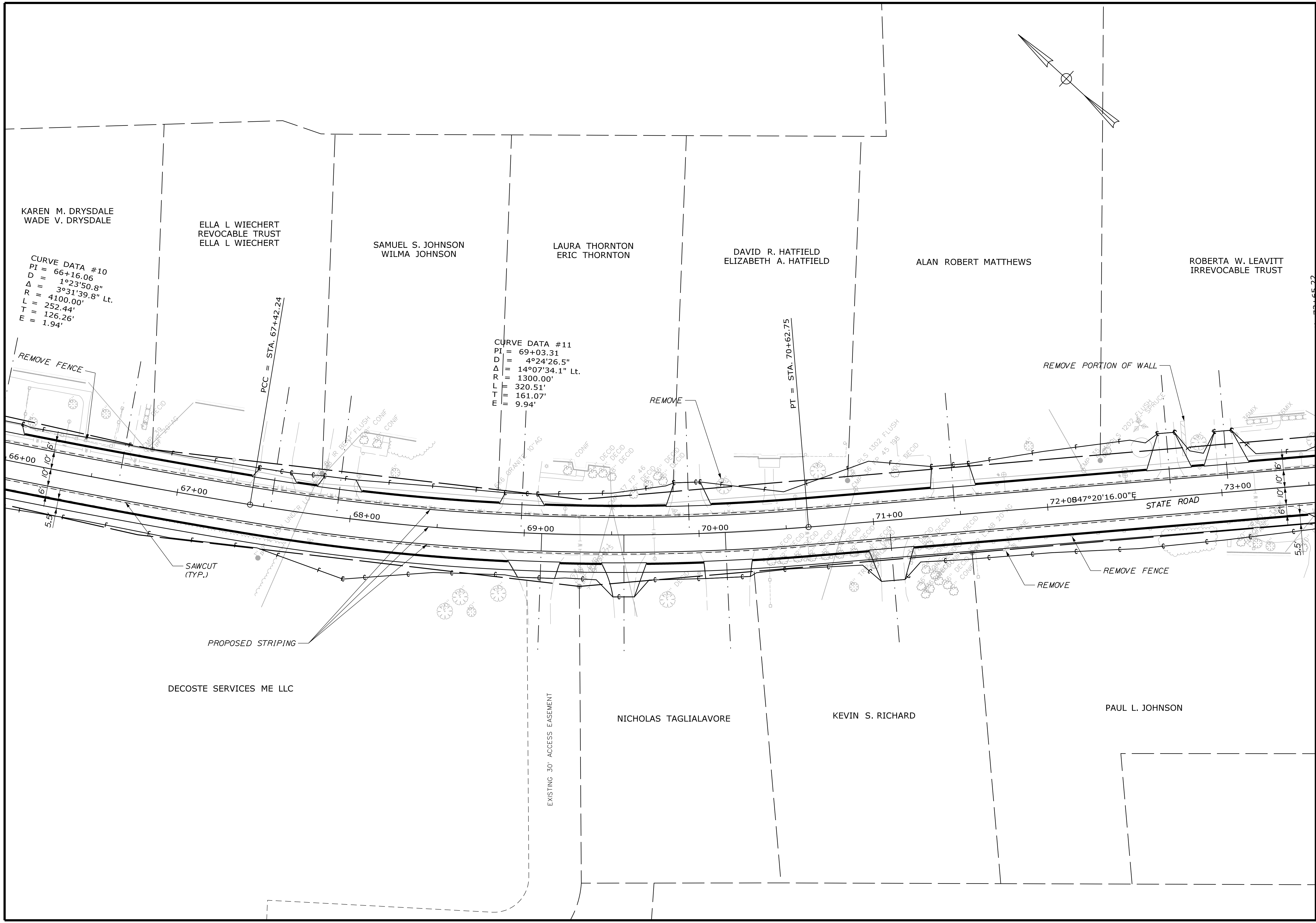

TOWN OF ELIOT		HIGHWAY PLANS	
STATE & BEECH ROAD		PLANS	
SHEET NUMBER		10	
		OF 22	
PROJ. MANAGER	J. BRUBAKER	BY	T. WOLFEL
CHECKED/REVIEWED	L. WEEK	DATE	7/2023
DESIGN/DETAILS	L. WEEK	SIGNATURE	
DESIGN/DETAILS		P.E. NUMBER	
REVISIONS 1		DATE	
REVISIONS 2			
REVISIONS 3			
REVISIONS 4			
FIELD CHANGES			

Date: 7/21/2023

Username: twolfel

Division: HIGHWAY

Filename: ... \HIGHWAY\MSTA_HDPlan_011.dgn

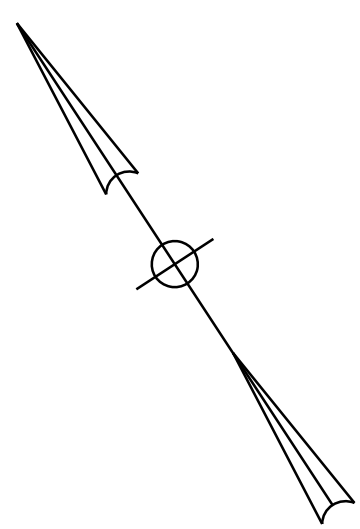
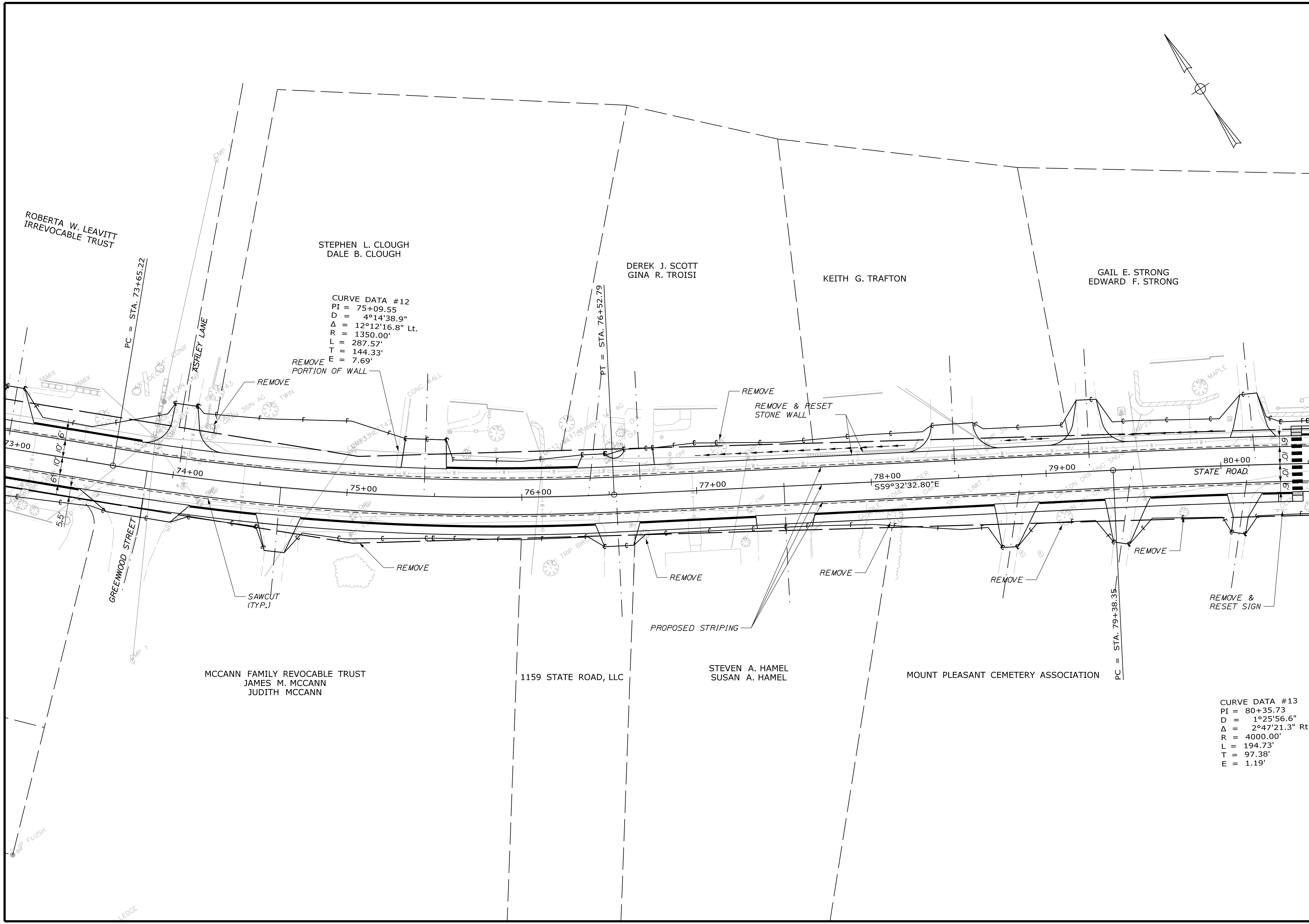

TOWN OF ELIOT		HIGHWAY PLANS	
ELIOT STATE & BEECH ROAD		PLANS	
SHEET NUMBER		11	
		OF 22	
PROJ. MANAGER	J. BRUBAKER	BY	T. WOLFEL
CHECKED/REVIEWED	L. WOLFEL	DATE	7/20/23
DESIGNED/DETAILED	L. WOLFEL	DATE	7/20/23
DESIGNED/DETAILED	L. WOLFEL	DATE	7/20/23
REVISIONS 1		SIGNATURE	
REVISIONS 2		P.E. NUMBER	
REVISIONS 3		DATE	
REVISIONS 4			
FIELD CHANGES			

Date: 7/21/2023

Username: twolfel

Division: HIGHWAY

Filename: ... \HIGHWAY\MSTA_HDPlan_012.dgn

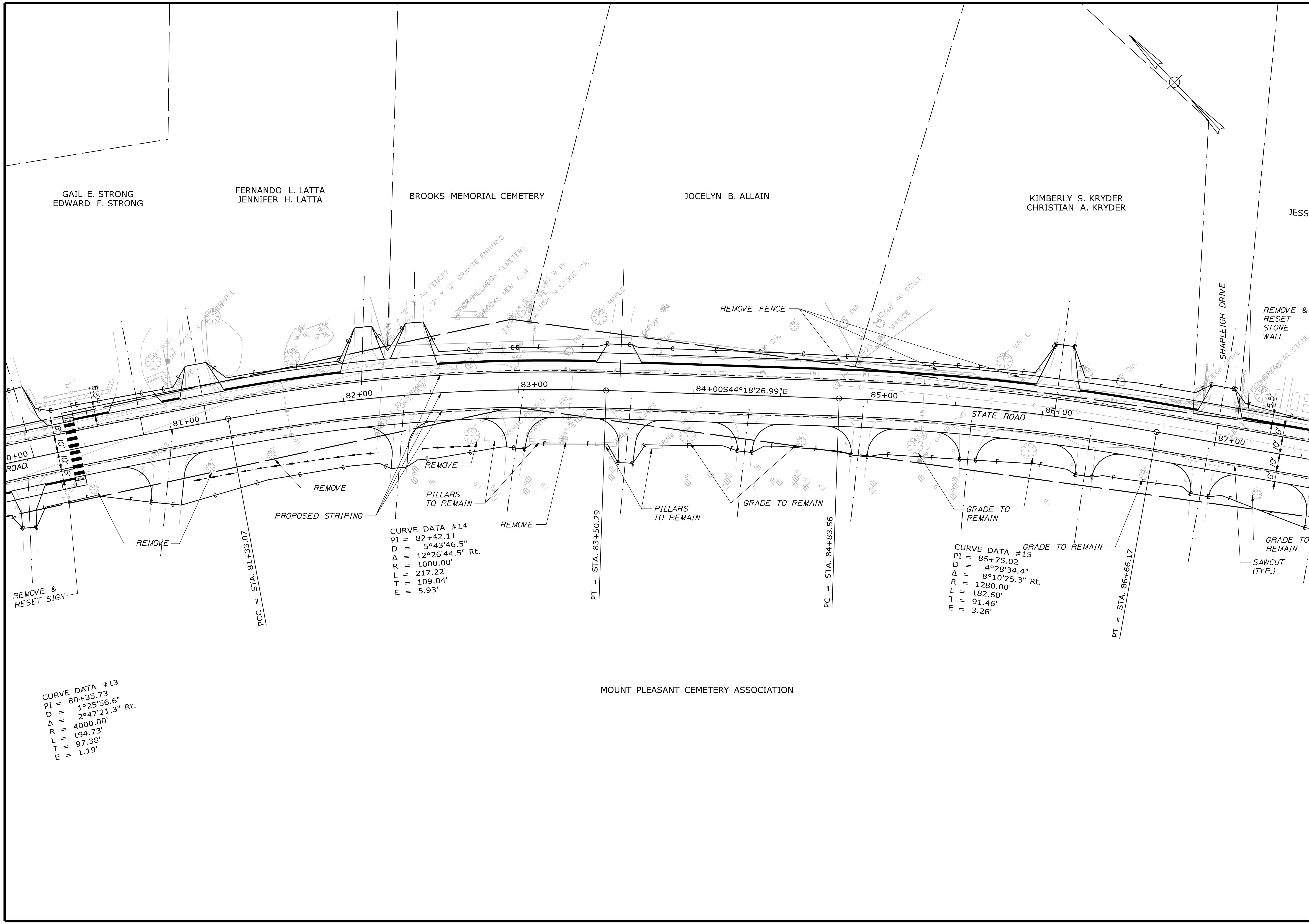

CURVE DATA #13
 PI = 80+35.73
 D = 1°25'56.6"
 Δ = 2°47'21.3" Rt.
 R = 4000.00'
 L = 194.73'
 T = 97.38'
 E = 1.19'

CURVE DATA #14
 PI = 82+42.11
 D = 5°43'46.5"
 Δ = 12°26'44.5" Rt.
 R = 1000.00'
 L = 217.22'
 T = 109.04'
 E = 5.93'

CURVE DATA #15
 PI = 85+75.02
 D = 4°28'34.4"
 Δ = 8°10'25.3" Rt.
 R = 1280.00'
 L = 182.60'
 T = 91.46'
 E = 3.26'

MOUNT PLEASANT CEMETERY ASSOCIATION

TOWN OF ELIOT		HIGHWAY PLANS	
STATE & BEECH ROAD		PLANS	
SHEET NUMBER		DATE	
12		7/2023	
OF 22		SIGNATURE	
		P.E. NUMBER	
		DATE	
		FIELD CHANGES	
		REVISIONS 1	
		REVISIONS 2	
		REVISIONS 3	
		REVISIONS 4	
		DESIGN DETAILED	
		CHECKED/REVIEWED	
		DESIGNED	
		BY	
		DATE	

Date: 7/21/2023

Username: twolfel

Division: HIGHWAY

Filename: ... \HIGHWAY\MSTA_HDPlan_014.dgn

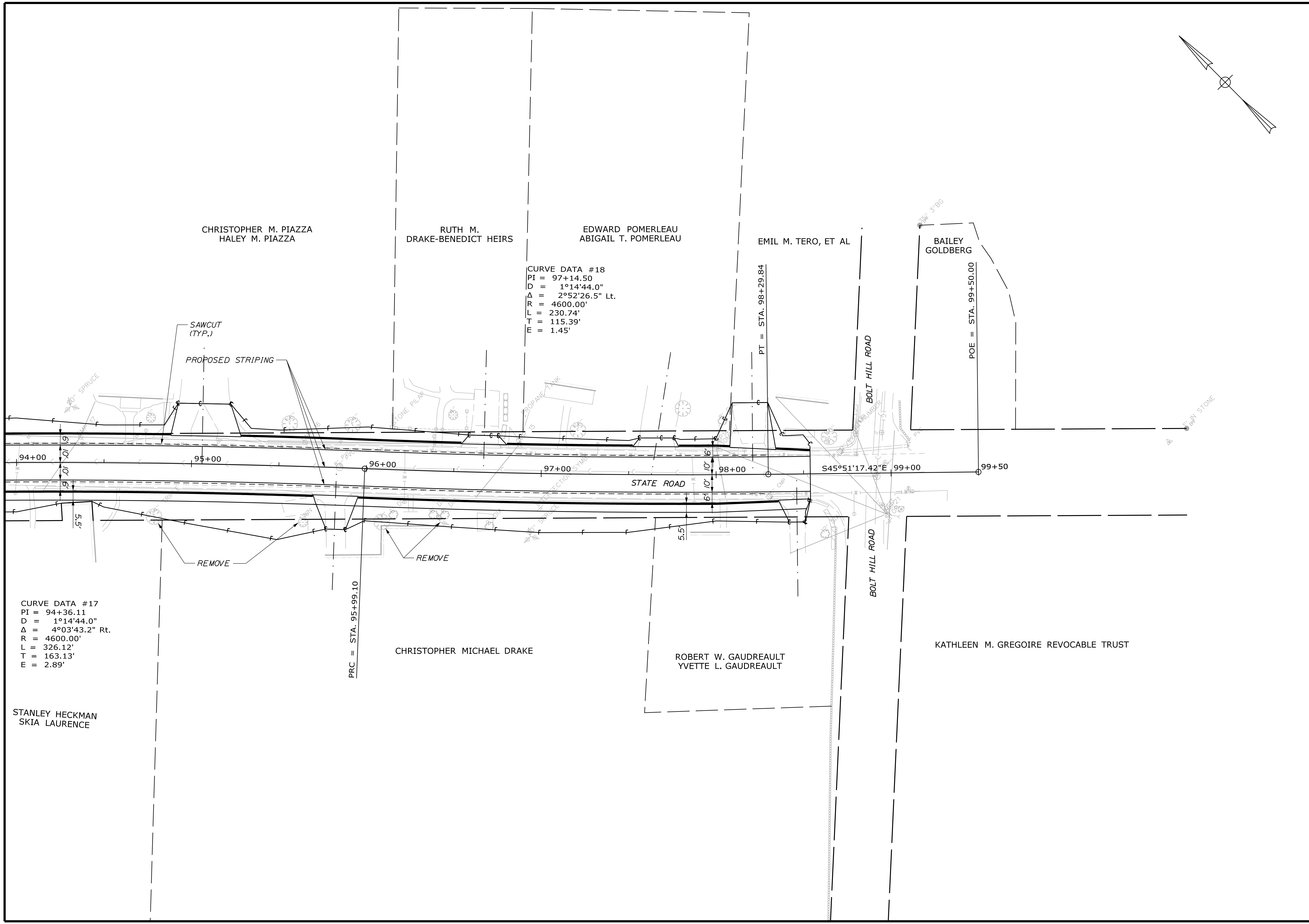
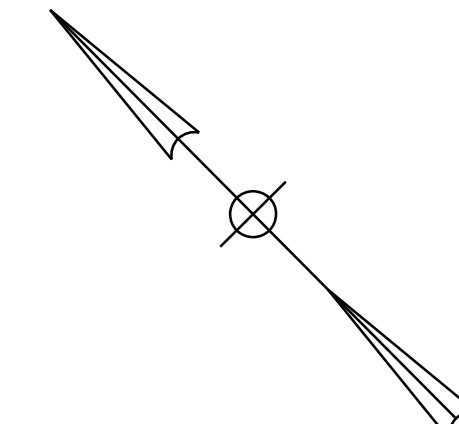

CURVE DATA #17
 PI = 94+36.11
 D = 1°14'44.0"
 Δ = 4°03'43.2" Rt.
 R = 4600.00'
 L = 326.12'
 T = 163.13'
 E = 2.89'

CURVE DATA #18
 PI = 97+14.50
 D = 1°14'44.0"
 Δ = 2°52'26.5" Lt.
 R = 4600.00'
 L = 230.74'
 T = 115.39'
 E = 1.45'

PRC = STA. 95+99.10

PT = STA. 98+29.84

POE = STA. 99+50.00

S45°51'17.42"E

TOWN OF ELIOT		HIGHWAY PLANS	
STATE & BEECH ROAD		PLANS	
SHEET NUMBER		14	
		OF 22	
PROJ. MANAGER	J. BRUBAKER	BY	T. WOLFEL
DESIGNED-DETAILED	T. WOLFEL	CHK	LEM
CHECKED-REVIEWED	L. MEEK	DATE	7/2023
DESIGNS-DETAILED		SIGNATURE	
REVISIONS 1		P.E. NUMBER	
REVISIONS 2		DATE	
REVISIONS 3			
REVISIONS 4			
FIELD CHANGES			

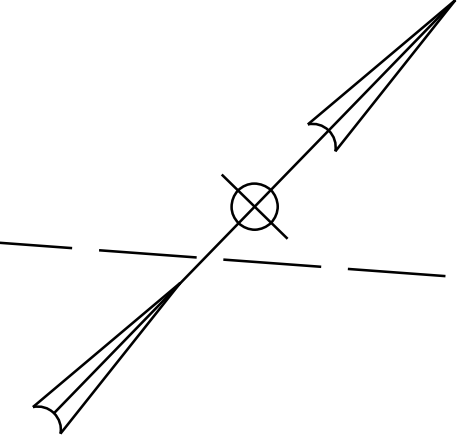
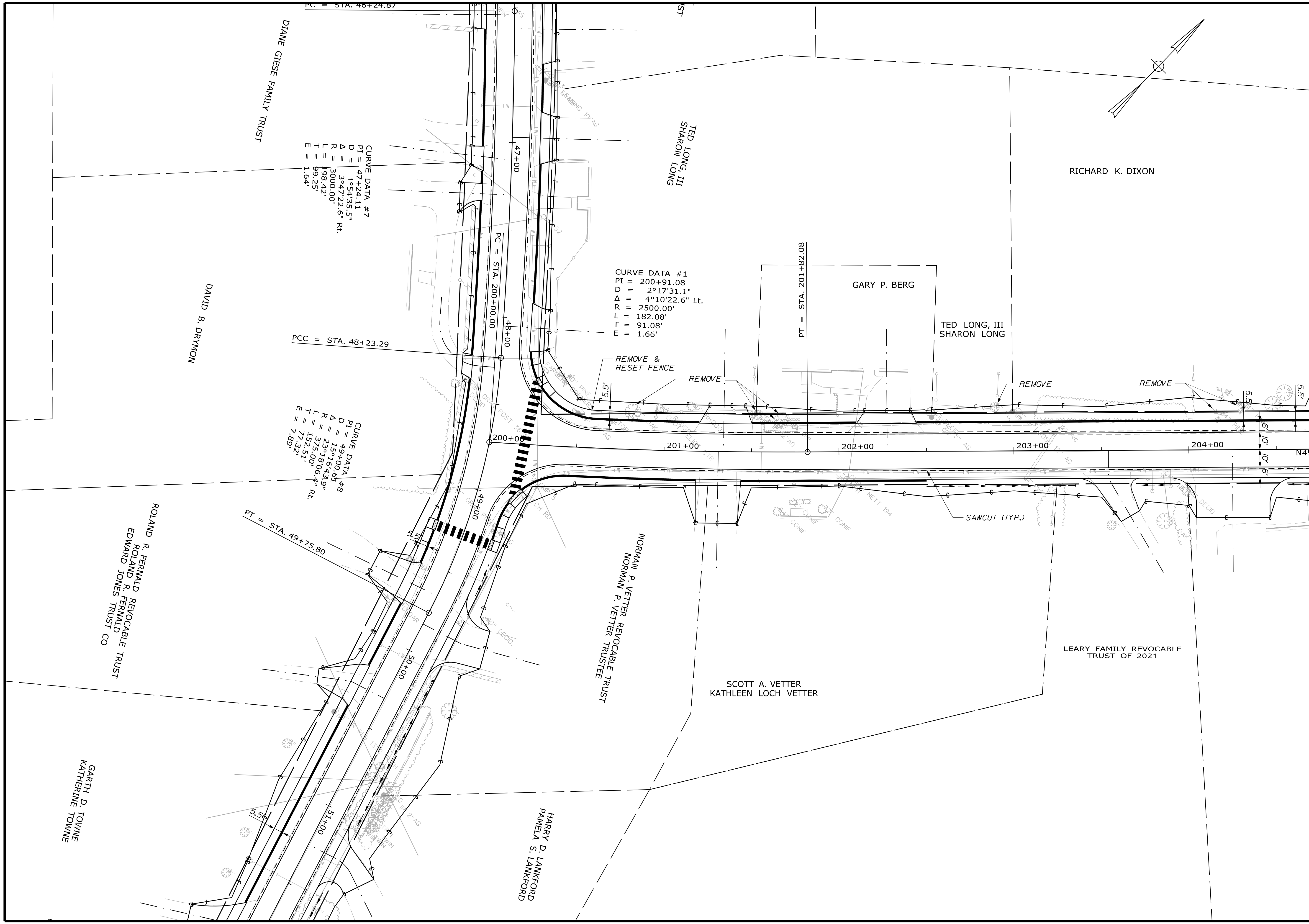

TOWN OF ELIOT		ELIOT STATE & BEECH ROAD		SHEET NUMBER	
		PLANS		15	
				OF 22	
PROJ. MANAGER	J. BRUBAKER	BY	T. WOLFEL	DATE	7/2023
CHECKED	L. WEEK	DESIGNED	L. WEEK	SIGNATURE	
DESIGNED	L. WEEK	REVISIONS 1		P.E. NUMBER	
REVISIONS 2		REVISIONS 3		DATE	
REVISIONS 4		FIELD CHANGES			

Date: 7/21/2023

Username: twolfel

Division: HIGHWAY

Filename: ... \HIGHWAY\MSTA_HDPlan_016.dgn

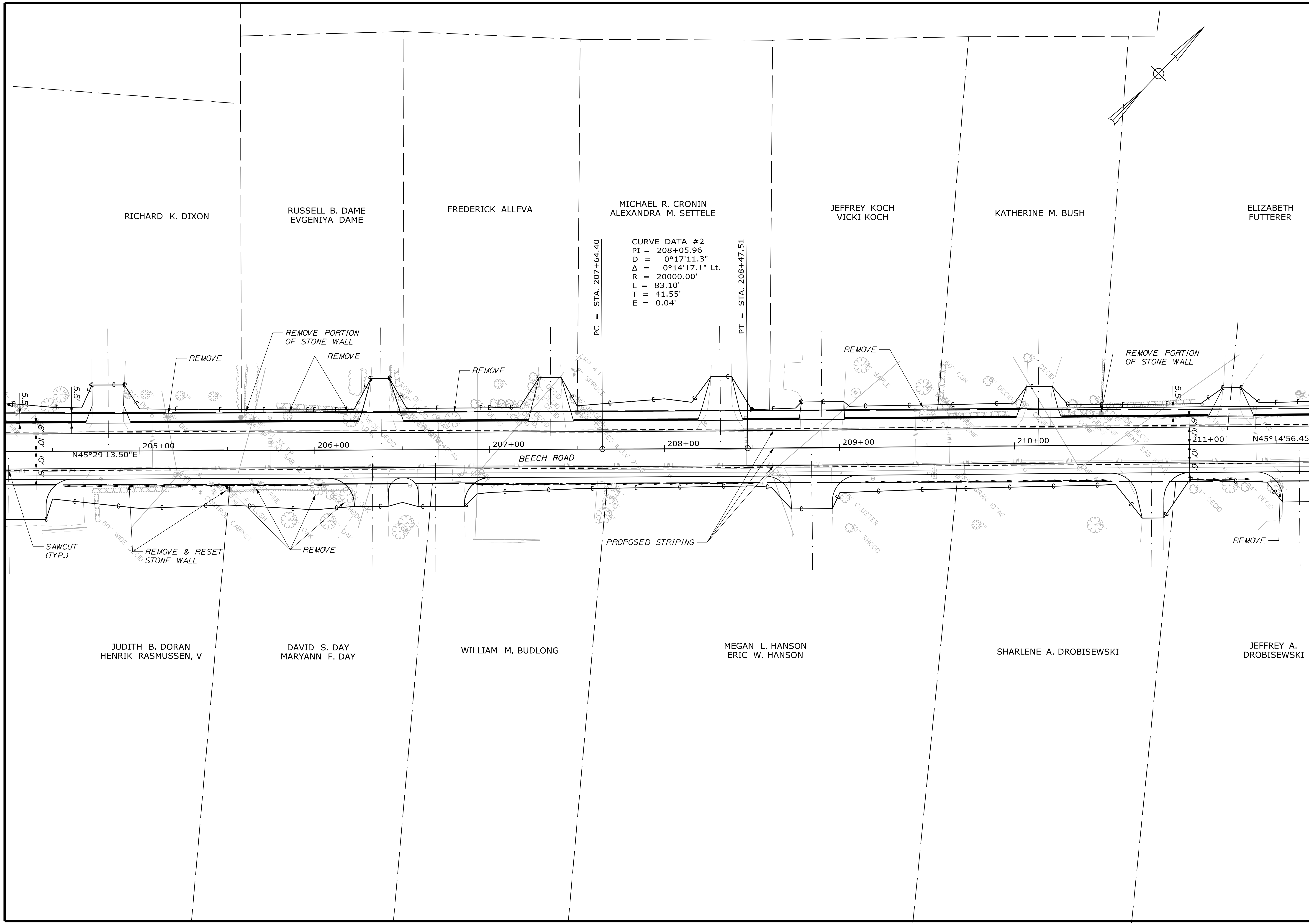

CURVE DATA #2
 PI = 208+05.96
 D = 0°17'11.3"
 Δ = 0°14'17.1" Lt.
 R = 20000.00'
 L = 83.10'
 T = 41.55'
 E = 0.04'

PC = STA. 207+64.40

PT = STA. 208+47.51

TOWN OF ELIOT		HIGHWAY PLANS	
ELIOT STATE & BEECH ROAD		PLANS	
SHEET NUMBER		16	
OF 22		DATE	
PROJ. MANAGER	BY	DATE	SIGNATURE
J. BRUBAKER	T. WOLFEL	7/2023	
DESIGN DETAILED	CHECKED	REVIEWED	DATE
L. WEEK	L. WEEK	7/2023	
DESIGN DETAILED	DESIGN DETAILED	DESIGN DETAILED	P.E. NUMBER
REVISIONS 1	REVISIONS 2	REVISIONS 3	DATE
REVISIONS 4	REVISIONS 5	REVISIONS 6	
FIELD CHANGES			

Date: 7/21/2023

Username: twolfel

Division: HIGHWAY

Filename: ... \HIGHWAY\MSTA_HDPlan_017.dgn

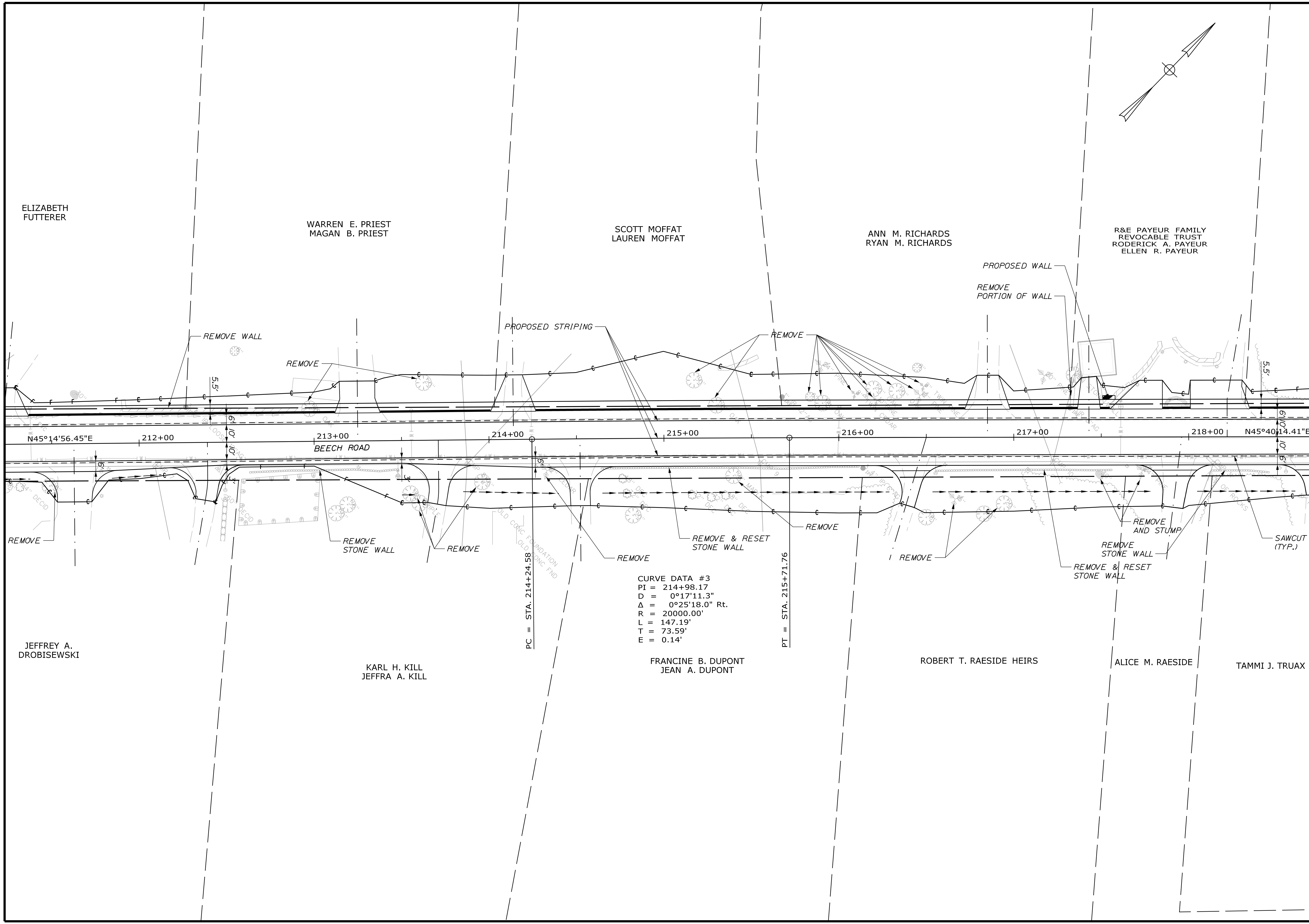

TOWN OF ELIOT		HIGHWAY PLANS	
PROJ. MANAGER	J. BRUBAKER	BY	T. WOLFEL
DESIGN DETAILED	T. WOLFEL	DATE	7/2023
CHECKED-REVIEWED	L. MEEK	DATE	7/2023
DESIGN DETAILED		SIGNATURE	
REVISIONS 1		P.E. NUMBER	
REVISIONS 2		DATE	
REVISIONS 3			
REVISIONS 4			
FIELD CHANGES			
ELIOT STATE & BEECH ROAD		PLANS	
SHEET NUMBER		17	
		OF 22	

Date: 7/21/2023

Username: twolfel

Division: HIGHWAY

Filename: ... \HIGHWAY\MSTA_HDPlan_018.dgn

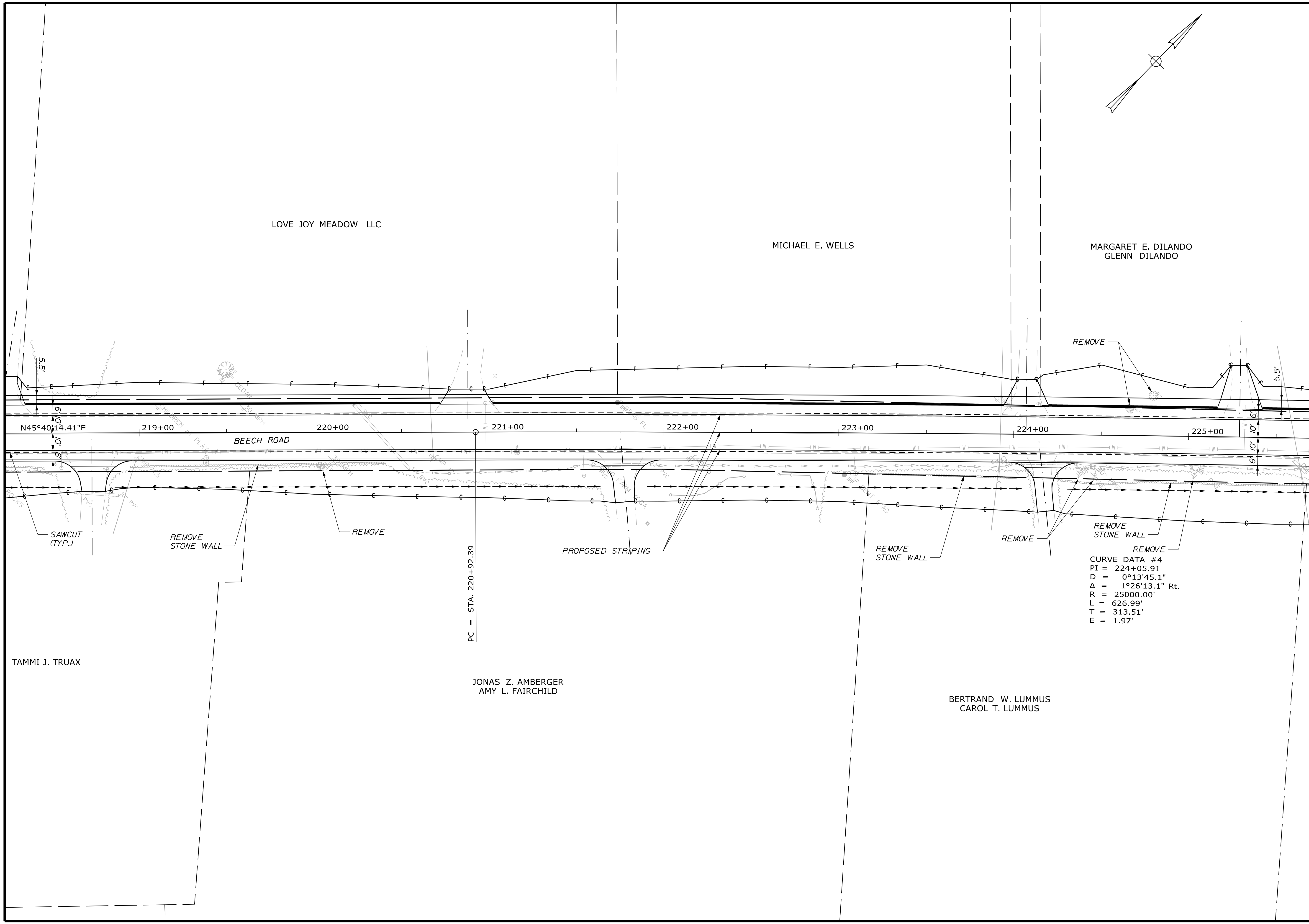

CURVE DATA #4
 PI = 224+05.91
 D = 0°13'45.1"
 Δ = 1°26'13.1" Rt.
 R = 25000.00'
 L = 626.99'
 T = 313.51'
 E = 1.97'

TOWN OF ELIOT		HIGHWAY PLANS	
STATE & BEECH ROAD		PLANS	
SHEET NUMBER		18	
		OF 22	
PROJ. MANAGER	J. BRUBAKER	BY	DATE
CHECKED/REVIEWED	T. WOLFEL	CHL	7/2023
DESIGNED/TAILED	L. MEEK	LEM	7/2023
DESIGNED/TAILED			
REVISIONS 1			
REVISIONS 2			
REVISIONS 3			
REVISIONS 4			
FIELD CHANGES			
SIGNATURE		P.E. NUMBER	
DATE		DATE	

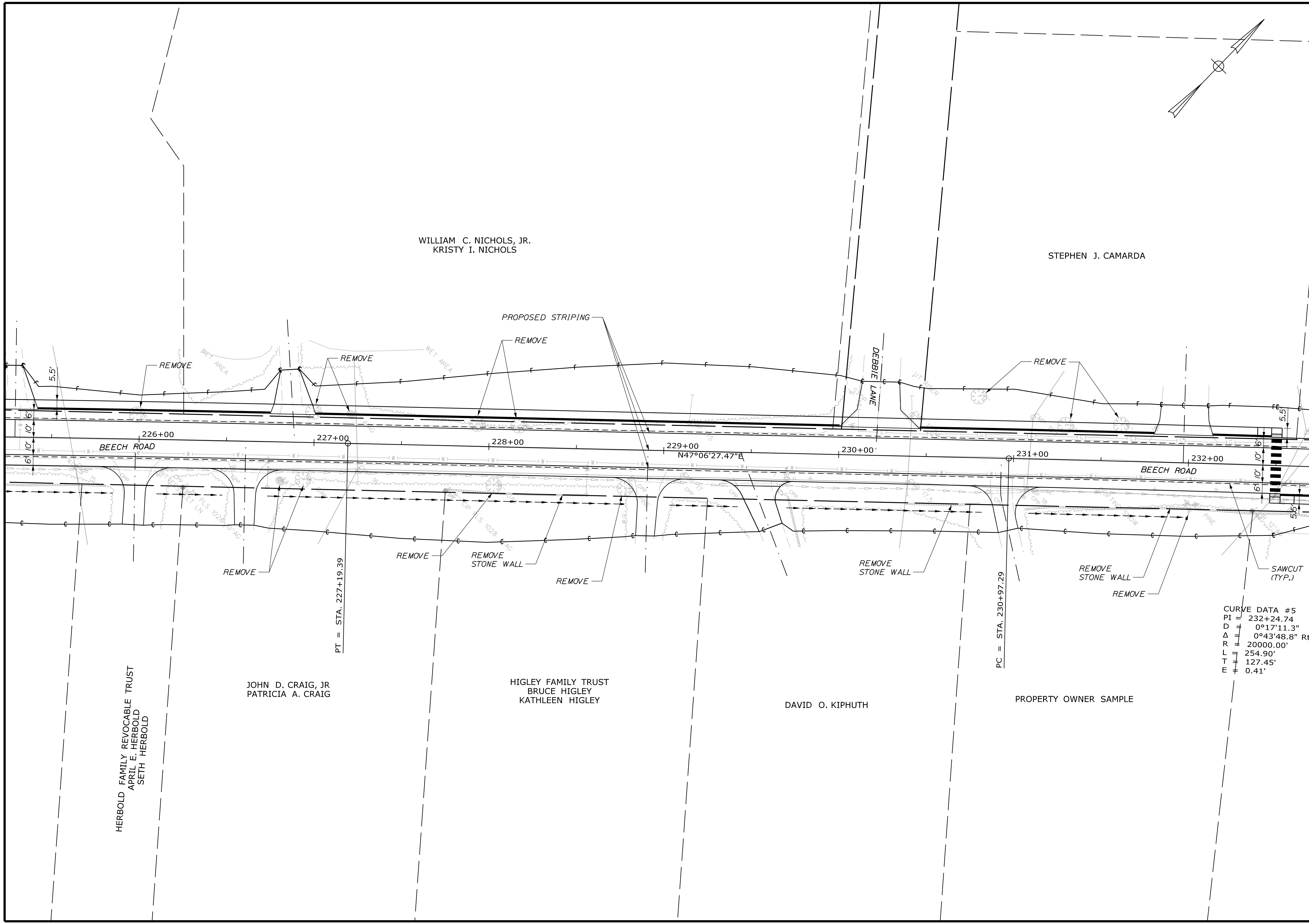

CURVE DATA #5
 PI = 232+24.74
 D = 0°17'11.3"
 Δ = 0°43'48.8" Rt.
 R = 20000.00'
 L = 254.90'
 T = 127.45'
 E = 0.41'

TOWN OF ELIOT		HIGHWAY PLANS	
STATE & BEECH ROAD		ELIOT STATE & BEECH ROAD	
PLANS		PLANS	
SHEET NUMBER		SHEET NUMBER	
19		19	
OF 22		OF 22	
PROJ. MANAGER	J. BRUBAKER	BY	DATE
CHECKED/REVIEWED	T. WOLFEL	CHL	7/2023
DESIGNED/TAILED	L. MEEK	LEM	7/2023
DESIGNED/TAILED			SIGNATURE
REVISIONS 1			P.E. NUMBER
REVISIONS 2			DATE
REVISIONS 3			
REVISIONS 4			
FIELD CHANGES			

Date: 7/21/2023

Username: twolfel

Division: HIGHWAY

Filename: ... \HIGHWAY\MSTA_HDPlan_020.dgn

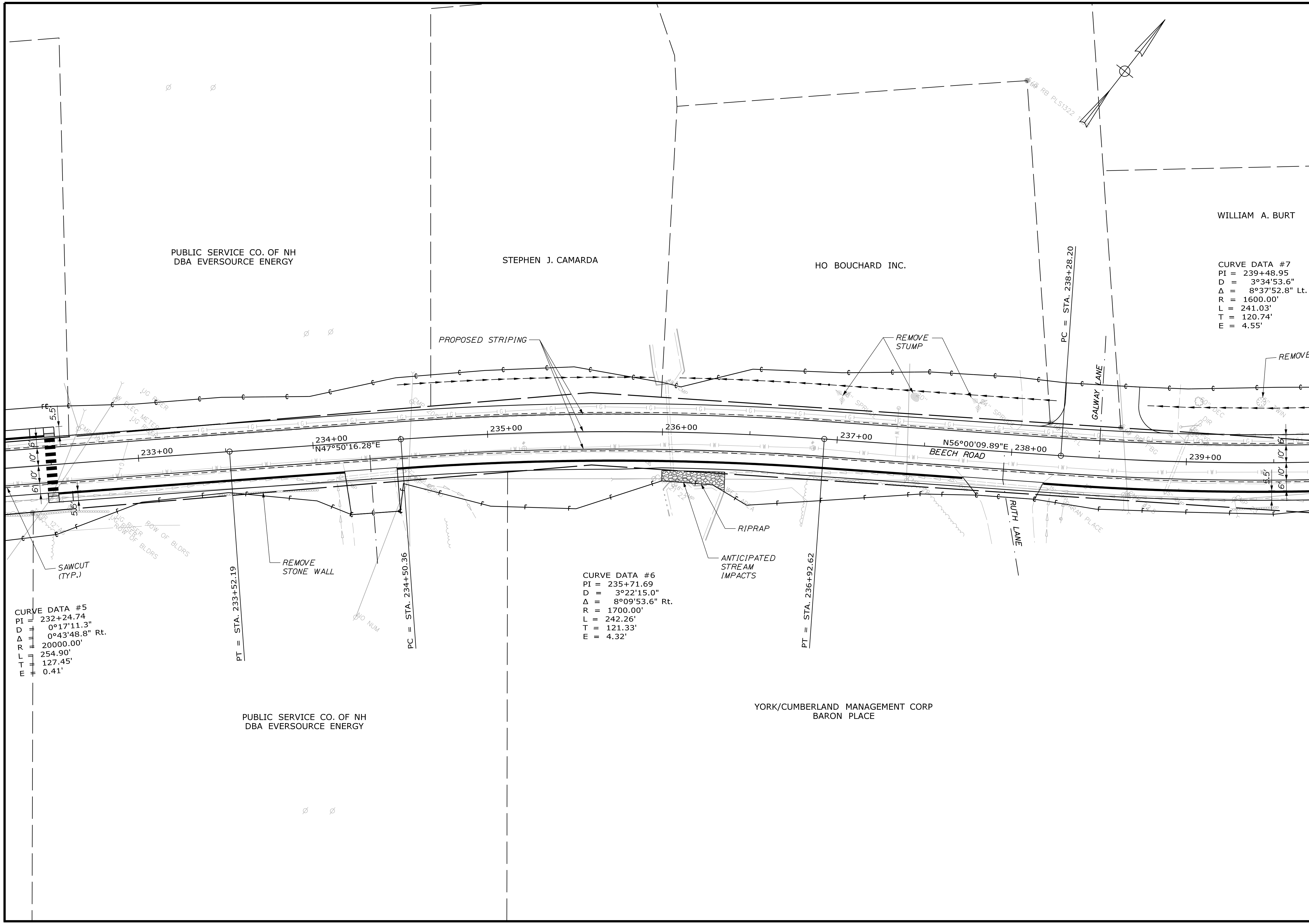

CURVE DATA #5
 PI = 232+24.74
 D = 0°17'11.3"
 Δ = 0°43'48.8" Rt.
 R = 20000.00'
 L = 254.90'
 T = 127.45'
 E = 0.41'

CURVE DATA #6
 PI = 235+71.69
 D = 3°22'15.0"
 Δ = 8°09'53.6" Rt.
 R = 1700.00'
 L = 242.26'
 T = 121.33'
 E = 4.32'

CURVE DATA #7
 PI = 239+48.95
 D = 3°34'53.6"
 Δ = 8°37'52.8" Lt.
 R = 1600.00'
 L = 241.03'
 T = 120.74'
 E = 4.55'

TOWN OF ELIOT		HIGHWAY PLANS	
STATE & BEECH ROAD		PLANS	
SHEET NUMBER		20	
OF 22			
PROJ. MANAGER	J. BRUBAKER	BY	T. WOLFEL
DESIGN DETAILED	T. WOLFEL	DATE	7/2023
CHECKED/REVIEWED	L. WEEK	DATE	7/2023
DESIGN DETAILED		SIGNATURE	
REVISIONS 1		P.E. NUMBER	
REVISIONS 2		DATE	
REVISIONS 3			
REVISIONS 4			
FIELD CHANGES			

Date: 7/21/2023

Username: twolfel

Division: HIGHWAY

Filename: ... \HIGHWAY\MSTA\HDPlan_021.dgn

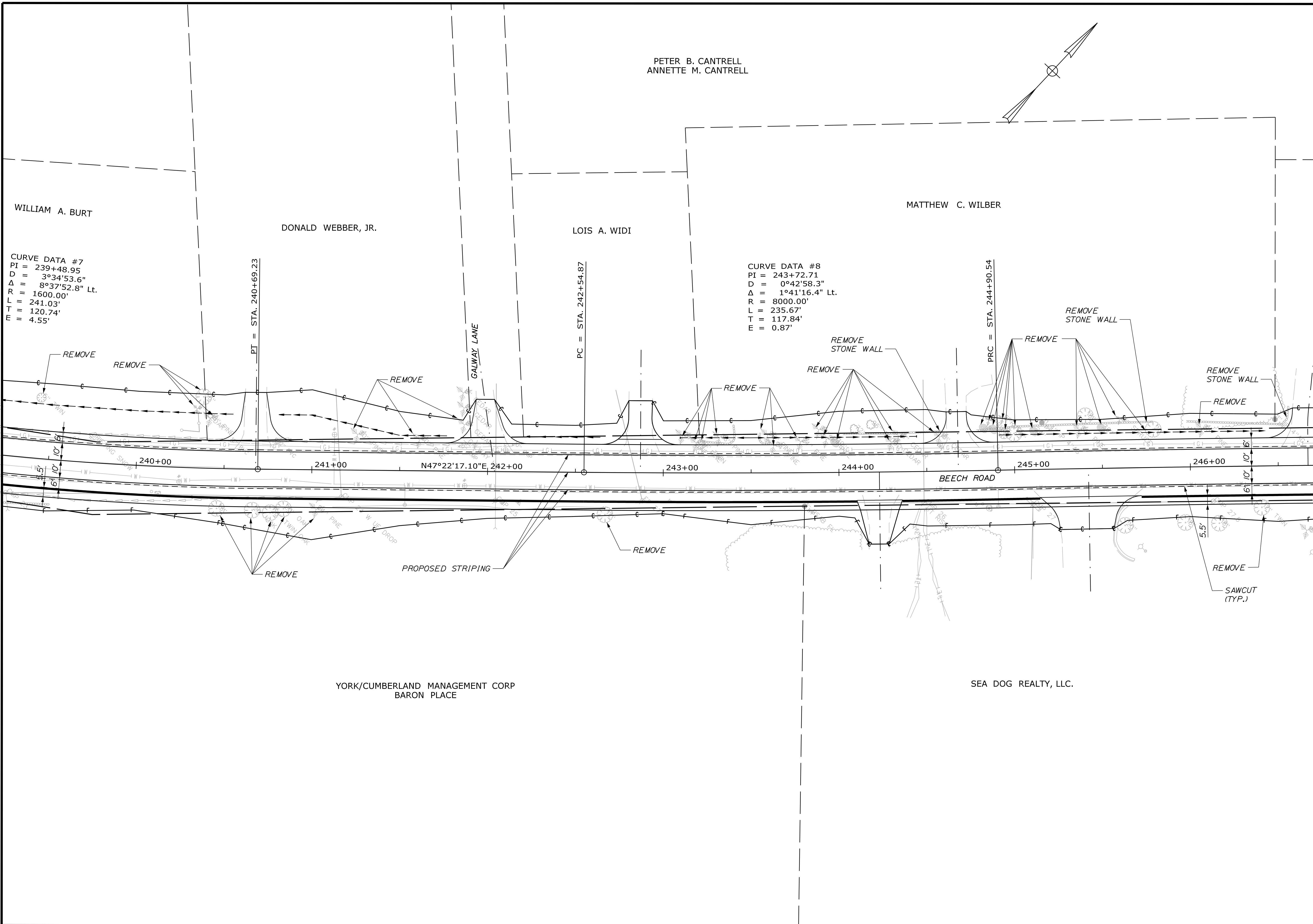

TOWN OF ELIOT		HIGHWAY PLANS	
ELIOT STATE & BEECH ROAD		PLANS	
SHEET NUMBER		21	
		OF 22	
PROJ. MANAGER	J. BRUBAKER	BY	T. WOLFEL
CHECKED-REVIEWED	L. WOLFEL	DATE	7/2023
DESIGN-DETAILED	L. WOLFEL	DATE	7/2023
DESIGN-REVIEWED	L. WOLFEL	DATE	7/2023
DESIGN-DETAILED	L. WOLFEL	DATE	7/2023
REVISIONS	1	P.E. NUMBER	
REVISIONS	2	DATE	
REVISIONS	3		
REVISIONS	4		
FIELD CHANGES			

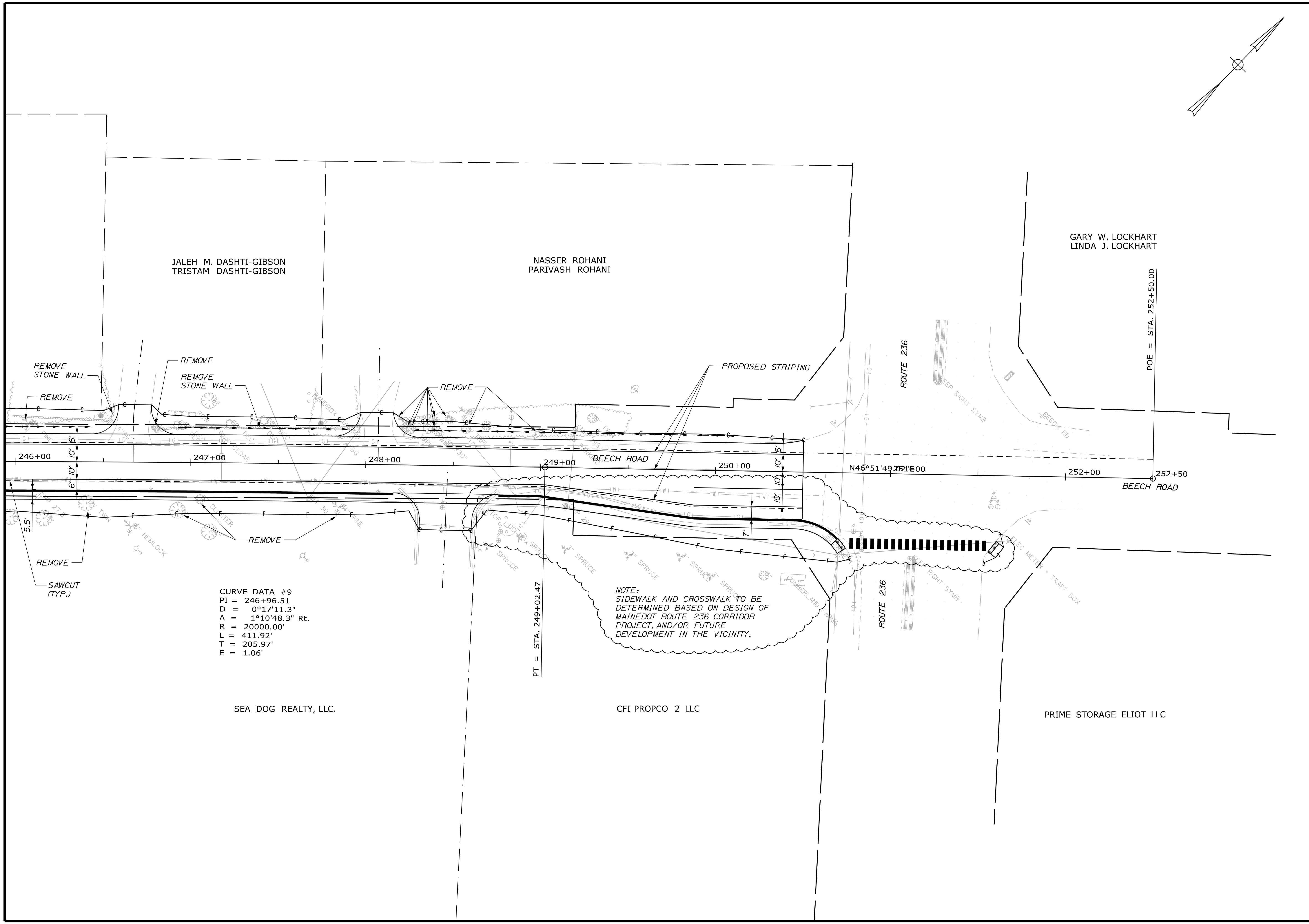

JALEH M. DASHTI-GIBSON
TRISTAM DASHTI-GIBSON

NASSER ROHANI
PARIVASH ROHANI

GARY W. LOCKHART
LINDA J. LOCKHART

CURVE DATA #9
 PI = 246+96.51
 D = 0°17'11.3"
 Δ = 1°10'48.3" Rt.
 R = 20000.00'
 L = 411.92'
 T = 205.97'
 E = 1.06'

NOTE:
 SIDEWALK AND CROSSWALK TO BE
 DETERMINED BASED ON DESIGN OF
 MAINE DOT ROUTE 236 CORRIDOR
 PROJECT, AND/OR FUTURE
 DEVELOPMENT IN THE VICINITY.

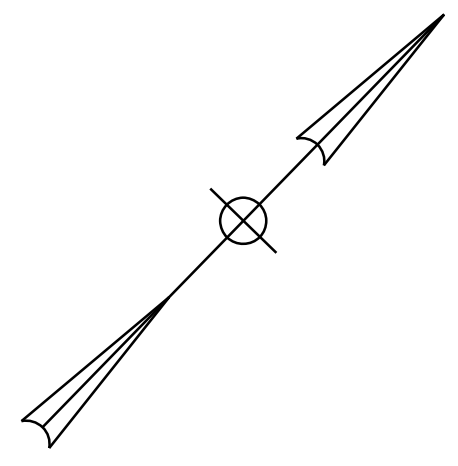

TOWN OF ELIOT STATE & BEECH ROAD PLANS		PROJ. MANAGER J. BRUBAKER	BY T. WOLFEL L. MEEK	DATE 7/2023 7/2023
		CHECKED-REVIEWED L. MEEK	SIGNATURE	P.E. NUMBER
SHEET NUMBER 22 OF 22		REVISIONS 1 REVISIONS 2 REVISIONS 3 REVISIONS 4 FIELD CHANGES	DATE	HIGHWAY PLANS